

# Technical Manual



UNITOR™ JET SPRAY UNIT 6BAR,  
10 LTR ST. STEEL, FPM

Product no. 572085



UNITOR™ JET SPRAY UNIT 6BAR,  
10 LTR STEEL, FPM

Product no. 572020

Version V01.112023

Date updated: 9 November 2023

## Table of Contents

<b>1. Important Safety Information</b>	<b>3</b>
1.1 General Safety	3
1.2 Warning	3
1.3 Safety	4
<b>2. Machine Description</b>	<b>5</b>
2.1 Explosion Drawing	5
2.2 Parts and Components	6
2.3 Spares	6
2.4 Accessories	6
<b>3. Technical Specifications</b>	<b>7</b>
3.1 Technical Data	7
3.2 Warranty	7
3.3 Declaration of Conformity	7
<b>4. Installation</b>	<b>8</b>
4.1 Assembly	8
<b>5. Intended Use</b>	<b>8</b>
5.1 Applications	8
5.2 Before Use	9
5.3 Directions for use	11
<b>6. Care and Cleaning</b>	<b>12</b>
6.1 After each use	12
6.2 Maintenance	12
6.3 Disposal	13
<b>7. Troubleshooting</b>	<b>14</b>
<b>Declaration of Conformity</b>	

## 1. Important Safety Information

### 1.1 General Safety

This equipment is intended for use with Wilhelmsen Cleaning Chemicals for cleaning on vessels only.

This product is not suitable for:

- a) Plant protection products
- b) Combustible liquids
- c) Hydrogen peroxide and similar substances that give off oxygen
- d) Corrosive substances (certain disinfecting and impregnating agents, acids and bases)
- e) Liquids containing ammonia
- f) Liquids at temperatures above 50 °C (122 °F)
- g) Wetting agents (surfactants), solvents, and liquids containing solvents which can cause or promote cracking in the applied plastics.
- h) Viscous or sticky liquids or liquids that form residues (dyes, greases)
- i) Use in applications for foodstuff

### 1.2 Warning

Improper use may result in dangerous injuries and environmental damage. Follow the safety notices and data sheets of the substance manufacturers before each application. Observe the specified maximum concentrations for chemical substances and preparations. Observe the legal and statutory regulations applicable in your country.



Warning: Under no circumstances should you use the product for:

- a) external sources of pressure without original compressed air filling valve
- b) for flaming
- c) for storing and holding liquids as an eyewash



Warning: Only trained, healthy and rested people may work with the device. You should not be under the influence of alcohol, drugs or medication. Keep the spraying devices safe from access to children. Children and adolescents must not use the device.

Take precautions to prevent hazardous substances from being misused.



Warning: The device may be used outdoors or in well-ventilated rooms only.



Warning: Check the device regularly and after a longer period of non-use. Have damaged parts or parts that do not work properly repaired immediately by our customer service department.

### 1.3 Safety



Keep bystanders away during spraying.  
Never spray on people, animals, electrical devices and lines, into the wind, or into bodies of water



Wear appropriate protective clothing, goggles and respiratory protection in line with the applicable national regulations when working with hazardous substances.



Avoid ignition sources in the environment.  
Do not allow the device to remain under pressure and/or exposed directly to sunlight. Make certain the device is not heated beyond the maximum operating temperature (refer to Table 1). Protect the device from frost and ammonia.



Never blow through the nozzles or valves with your mouth.



There is a risk of slipping or tripping on smooth or wet surfaces, snow, ice, on slopes and on uneven terrain.



Have damaged parts or parts that do not work properly repaired immediately by our customer service department or by service partners authorized by us.  
The effect of the safety valve must not be bypassed or made inoperative.



Use only original spare and accessory parts. Wilhelmsen Ships Service will not assume any liability resulting from the use of third-party parts.



When pumping, always observe the pressure gauge to ensure the maximum spraying pressure is not exceeded (refer to Table 1).  
All excess pressure must be released from the device before filling, after use, before carrying out maintenance work, on work breaks, and before placing it in storage.



Points to note when transporting the device: Transport the device in such a way that it is protected against damage and tipping. All excess pressure must be released from the device.

## 2. Machine Description

### 2.1 Explosion Drawing

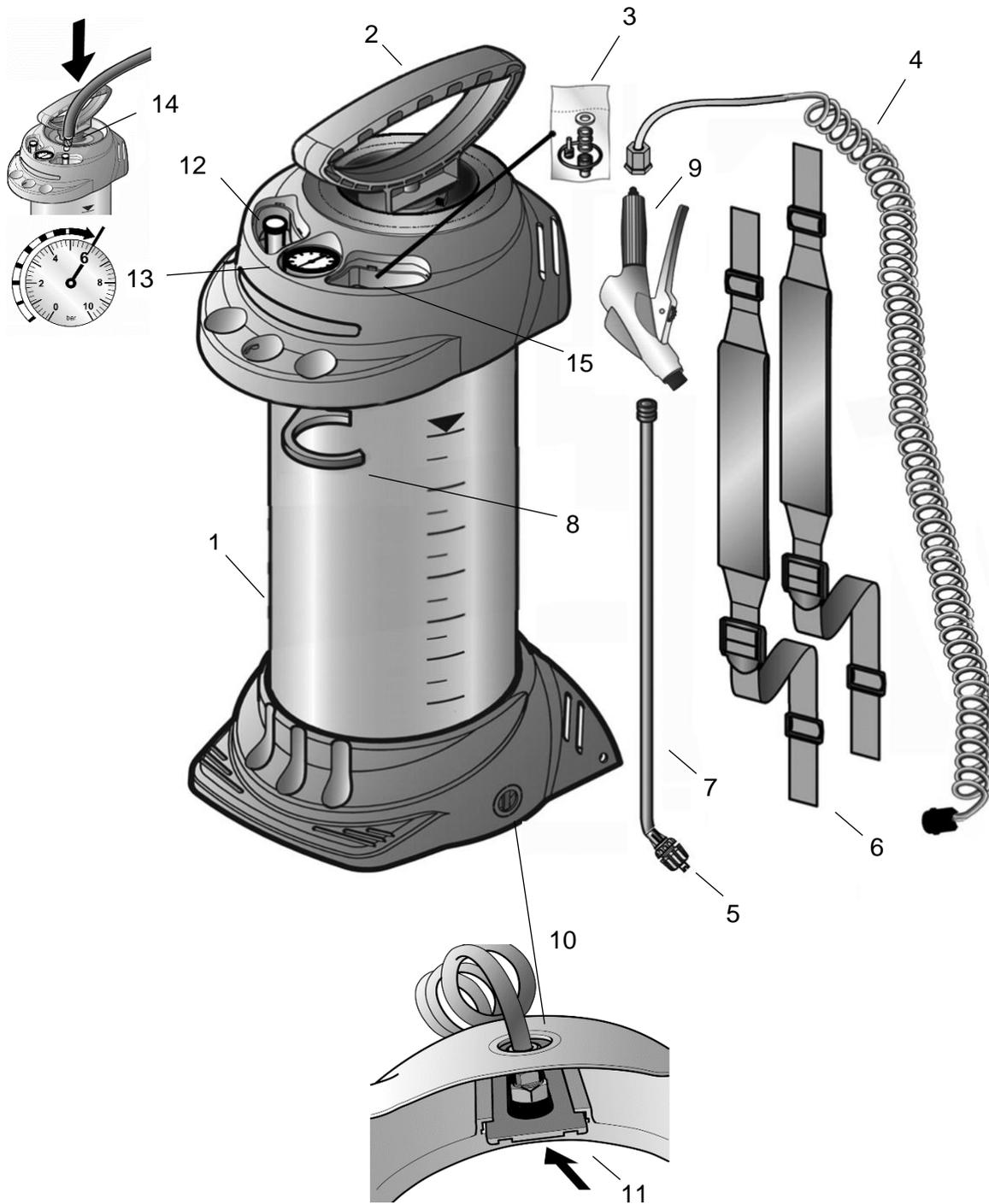

Figure 1

## 2.2 Parts and Components (refer to Figure 1)

Part No.	Description
1	Tank
2	Pump
3	Spare parts pouch
4	Spray line
5	Flat Jet nozzle
6	Back straps
7	Spray lance
8	Pump holder
9	Shut-off valve
10	Outlet port
11	Safety lock for hose
12	Safety valve
13	Pressure gauge
14	Compressed air hose
15	Compressed air filling valve

## 2.3 Spares

What is included in the spare parts pouch:

Item	Quantity
O-Ring 10x3 FPM	2
Seal D15 x D11 x 2 mm	4
Seal D14 x D9,7 x 2 mm	2
O-RING 42 X 4 MM FPM (HD)	1
O-RING 47x5,33 MM FPM (DS)	1
Piston washer	1
Seal D16.6 x D8 x 2mm	1
O-RING 17x2,5MM FPM	2
O-RING 4,42 X 2,62 MM FPM	1
O-RING 3 X 1,5 MM FPM	1
Valve disc FPM (DS)	1

## 2.4 Accessories

Product Number	Item	Description
770983	Filling valve 6222-NA	Tire valve connection Suitable for compression sprayers 6 bar
770984	Filling valve 6222-NB	Plug-in coupling NW7.2 Suitable for compression sprayers 6 bar

### 3. Technical Specifications

#### 3.1 Technical Data

Type	3585P	3615P
Max. filling amount	10 litres	10 litres
Total contents	13 litres	13 litres
Max. spraying pressure	6 bar (88 psi)	
Max. operating temperature	50°C (120°F)	
Weight when empty	5.2 kg	4.7 kg
Total weight max. approx.	15 kg	15 kg
Material of tank	Steel with polyester coating	Stainless steel
Where device is carried	Back	Back
Technical residual quantity	0.03 litres	
Max. volume flow	0.78 l/min	
Recoil force	< 5N	

Spraying rate / Spraying pressure	Flat jet nozzle		
	80-01	80-02	1.1 mm
1.5 bar (21.8 psi)	0.29 l/min	0.56 l/min	0.48 l/min
2.0 bar (29.0 psi)	0.32 l/min	0.64 l/min	0.56 l/min
3.0 bar (43.5 psi)	0.39 l/min	0.78 l/min	0.69 l/min

#### 3.2 Warranty

The warranty for the device is 12 months from date of delivery. From the time it is first purchased for a period of the legally valid required warranty period this device will not exhibit any material or processing errors.

If defects are discovered during the warranty period, the manufacturer or the distributor in your country will repair the device without charging for the labour or material or (at the discretion of the manufacturer) replace the device itself or its defective parts. If such defects are discovered, please contact us immediately.

The warranty does not include wearing parts (seals, O-rings, diaphragm, etc.) or defects, which have occurred due to improper use or unforeseeable circumstances.

#### 3.3 Declaration of Conformity

Refer to end of document

## 4. Installation

### 4.1 Assembly

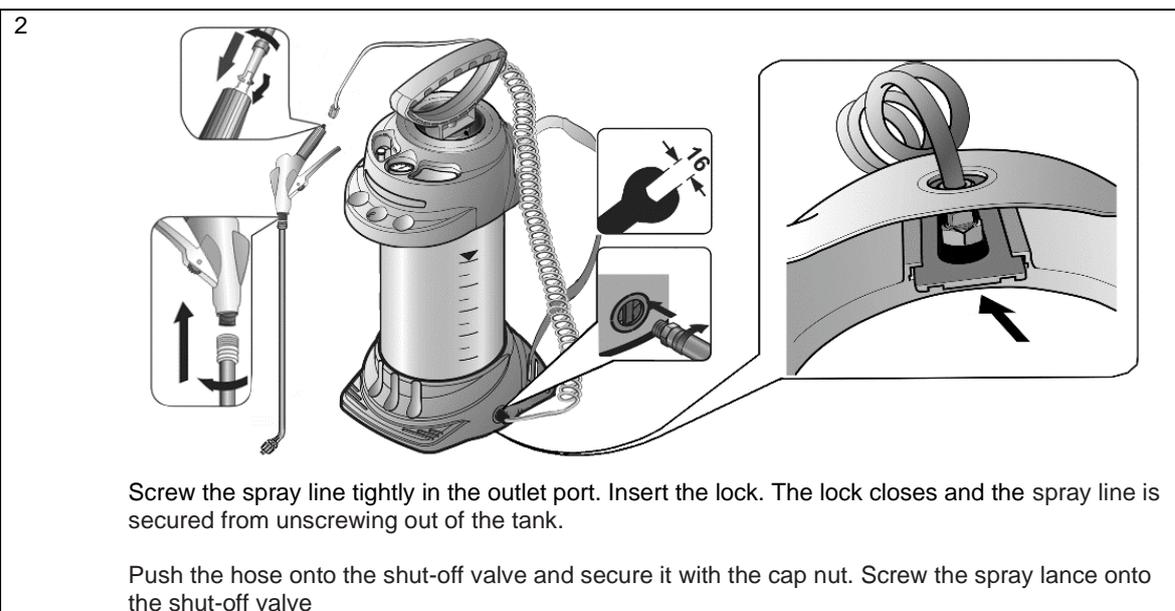
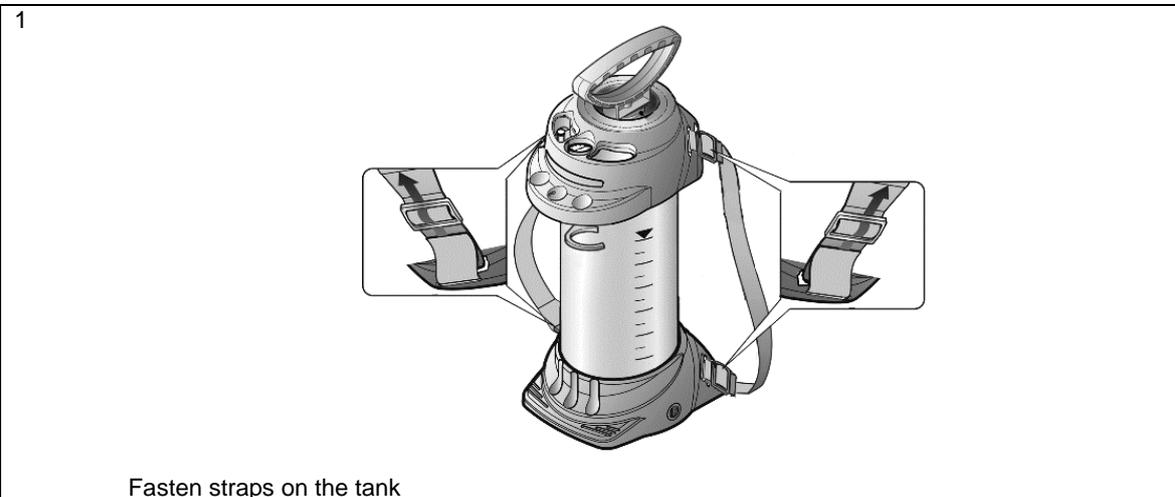

## 5. Intended Use

### 5.1 Applications

The product designed for the spraying of forming oils and low-viscosity mineral oils, slightly alkaline construction chemicals ( $\text{pH} \leq 9$ ). It can also be used for solvent-free and chloride-free, neutral cleaning agents as well as low-viscosity, solvent-free emulsion paints and paints.

The Stainless-Steel version (product number 572085) is recommended for acid-based rust removers and solvent based cleaners. Please see the table below for recommended Unitor™ cleaning chemicals:

UNITOR™ JET SPRAY UNIT 6BAR, 10 LTR ST. STEEL, FPM (572085)	
Recommended Chemicals	Product Number
Metalbrite HD	571679
Metalbrite	571661
Deckclean NP	765990
HP Wash	571729
Coldwash HD	571430
Cleanbreak	571497
Electrosolv E	604389
Enviroclean	765018

The Steel version (product number 572020) is recommended for water-based chemicals. Some of Unitor™ recommended cleaning chemicals are as follows:

UNITOR™ JET SPRAY UNIT 6BAR, 10 LTR STEEL, FPM (572020)	
Recommended Chemicals	Product Number
Aquabreak PX	575613
Enviroclean	765018
Easyclean Cleaning & Disinfectant	778845
Fore & Aft	571554
Aquatuff	607826

## 5.2 Before Use

Check the condition of the tank, pump, spray line with shut-off valve, pressure gauge and spray lance. Pay special attention to the connections between the tank and shut-off valve and to the condition of the pump threading and spray line.

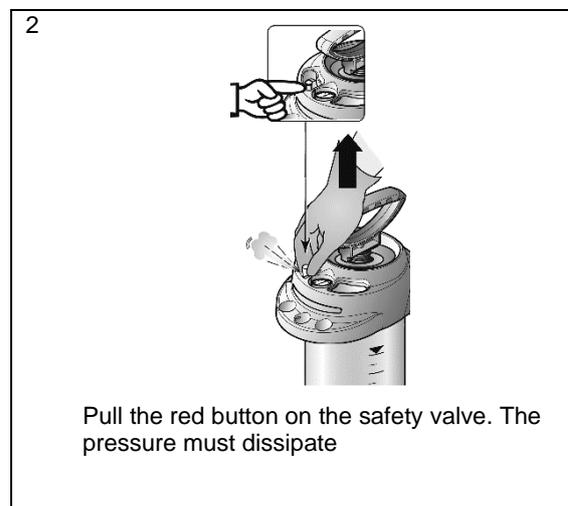
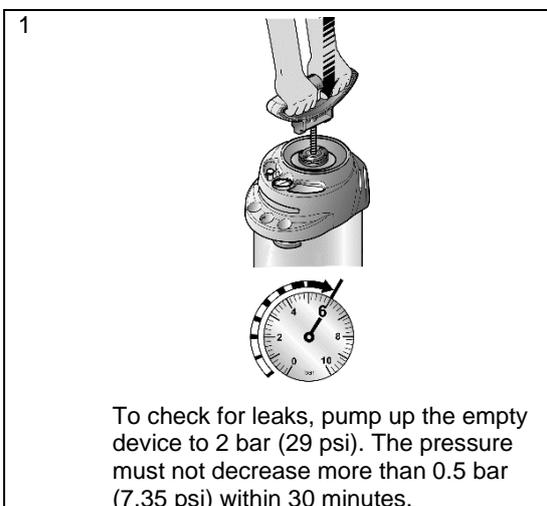

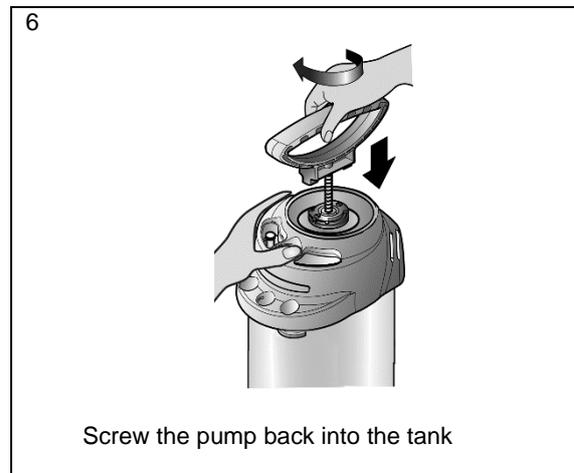
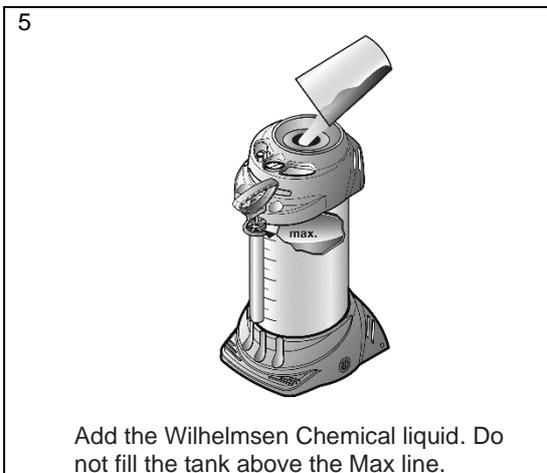
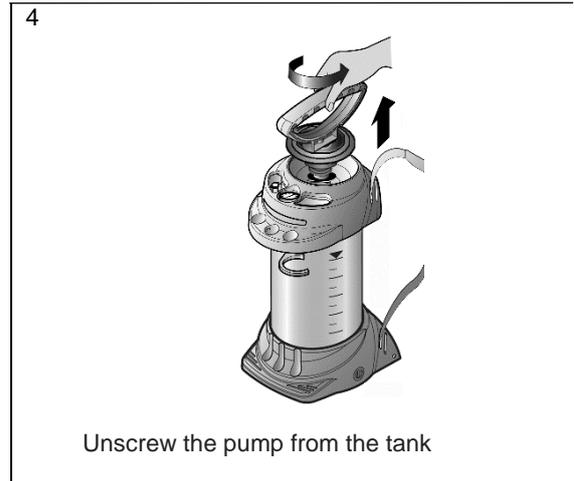
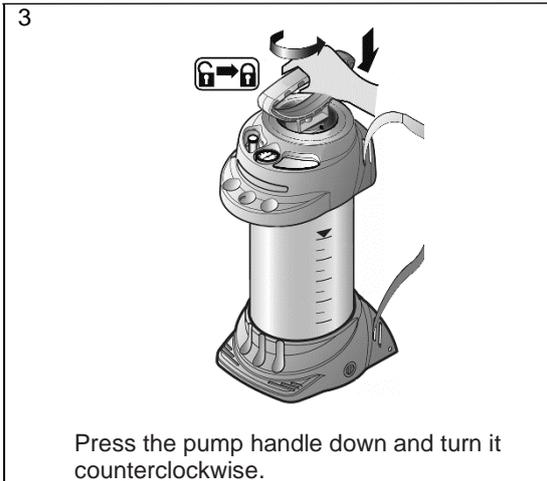

**Without compressed-air filling valve**

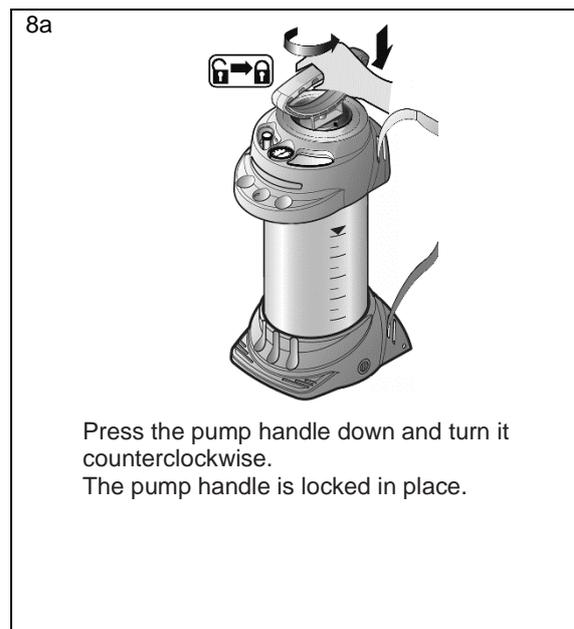
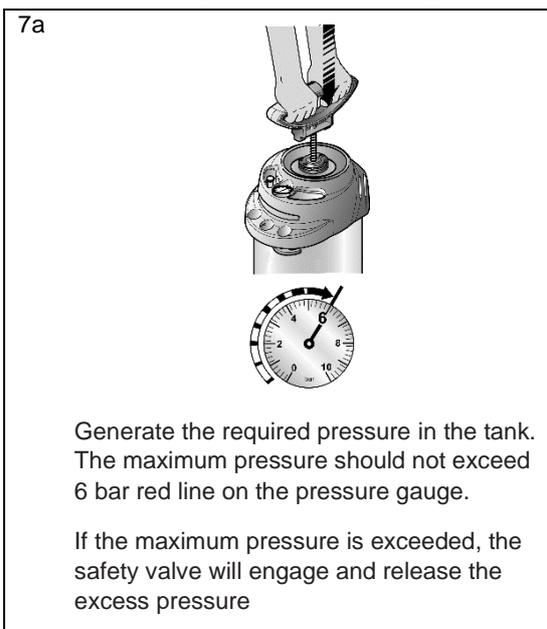

(Optional) With compressed-air filling valve

7b

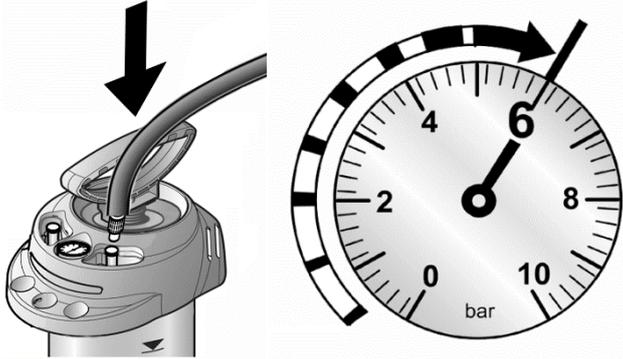

Connect the compressed-air hose to the compressed-air filling valve (refer to **Section 2.4 Accessories**). Pressure is built up max. 6 bar (88 psi)  
Ensure that the initial pressure is not higher than 15 bar (218 psi). When the required pressure has built up, remove the compressed-air hose

5.3 Directions for use

Operate the device only while it is vertical or suspended upright and nearly vertical. Avoid allowing drops of spray to drift onto areas that are not being treated.



Suspend the device from your shoulder or place it on your back.

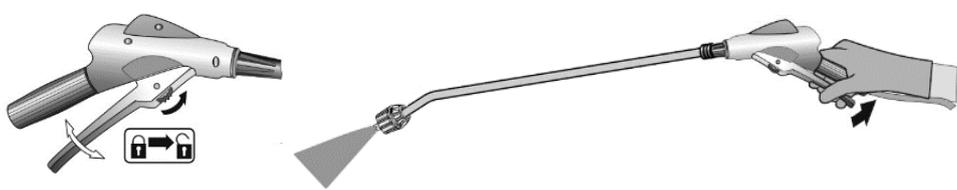

Unlock the lever on the shut-off valve.  
Unintentional spraying is prevented after locking. If required, reset the lock and activate the shut-off valve.

The shut-off valve must open and close

To prevent dripping, hold the spray wand up when first spraying and activate the shut-off valve until no more liquid mixed with air is emerging from the nozzle.

Make certain the optimum spraying pressure is set. Check the reading on the pressure gauge. If the spraying pressure decreases more than 0.5 bar (7.3 psi) from the optimum level, pump some more.

If liquid mixed with air emerges from the nozzle, the tank is empty.

## 6. Care and Cleaning

### 6.1 After each use

 Warning: Never leave liquid in the device

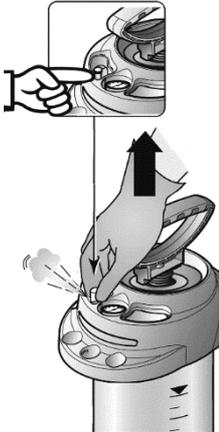
	<p>Pull up the red button on the safety valve until all excess pressure is released from the tank.</p> <p>Lock the pump handle in place.</p> <p>Unscrew the pump from the tank.</p> <p>Collect and dispose of the residual liquid and the tank according to all applicable laws, requirements and regulations.</p> <p>Empty and rinse the device with clear water.</p> <p>Wipe off the device with a moist cloth.</p> <p>For drying and storing the device, keep the tank and pump separate in a dry place protected from sunlight and freezing temperatures.</p>
--	---

### 6.2 Maintenance

Clean the product after using the device 50 times or at least once a year:

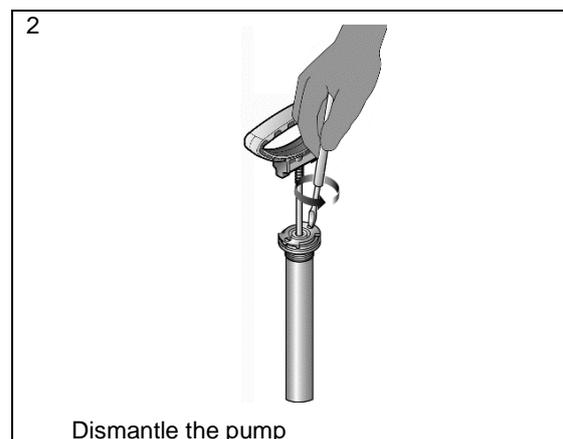
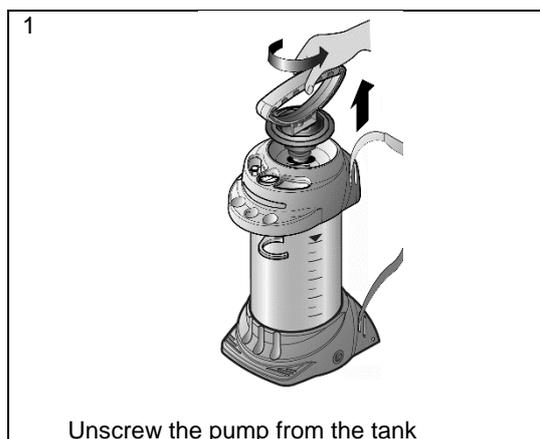

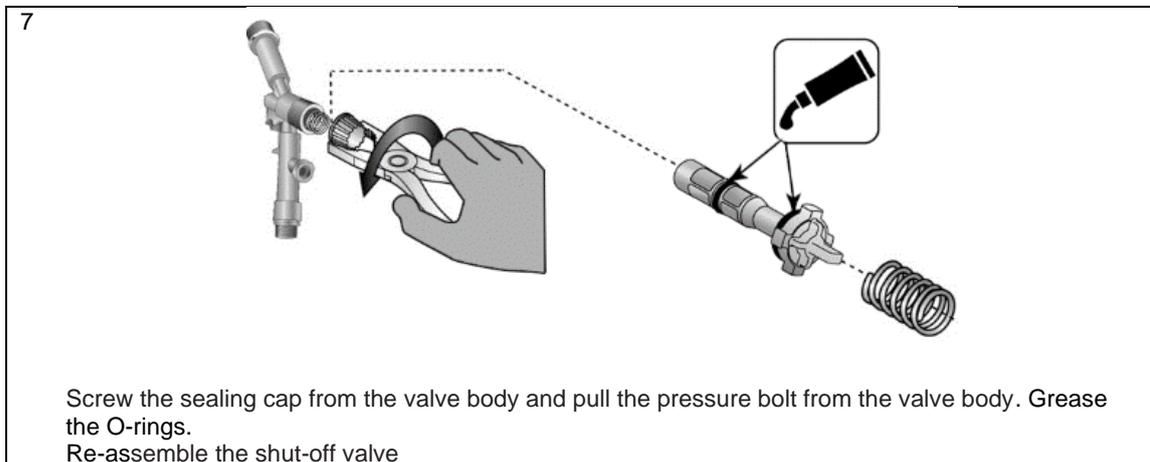
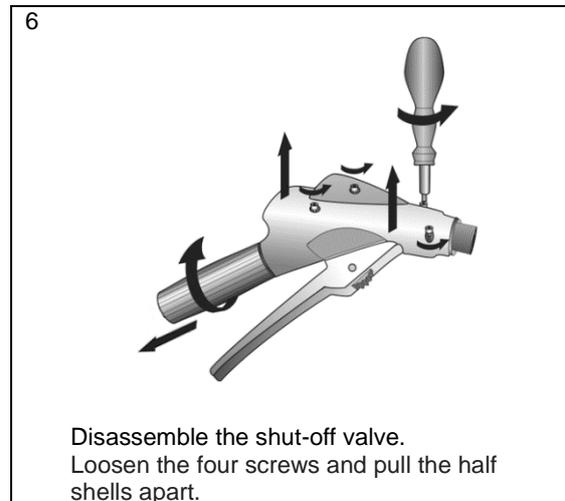
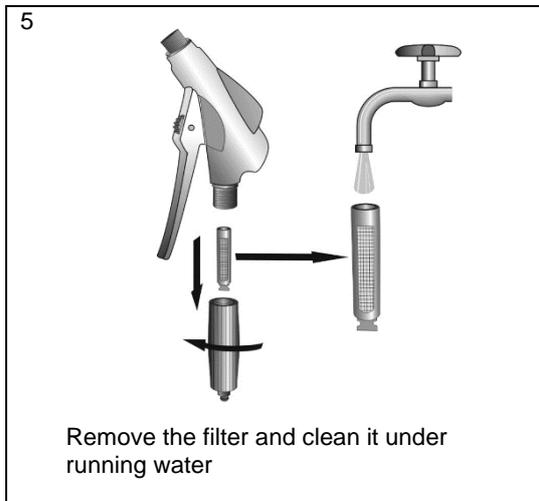
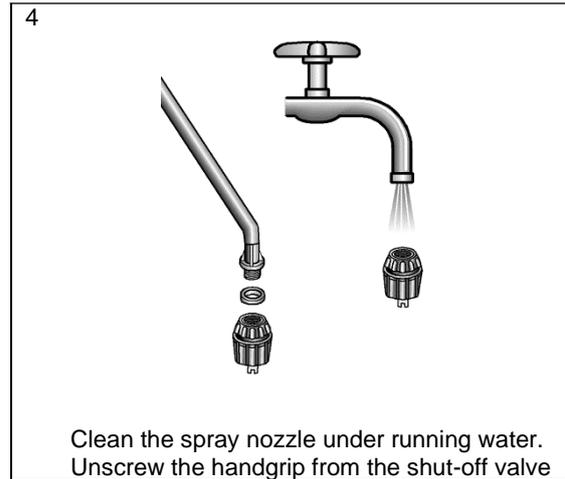
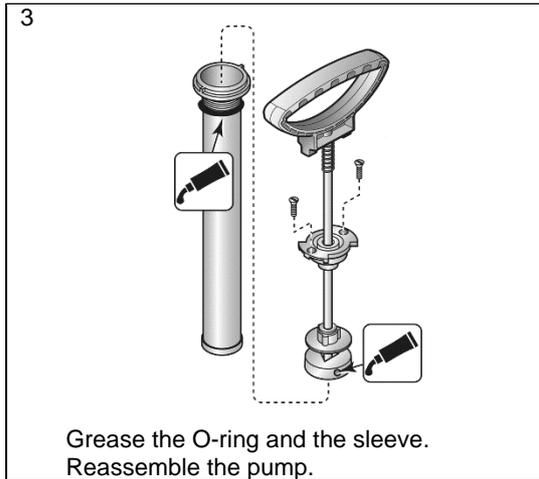

### 6.3 Disposal

Collect and dispose of the residual liquid and the tank according to all applicable laws, requirements and regulations.

## 7. Troubleshooting

Use only original spare and accessory parts

Fault	Cause	Remedy
No pressure builds up in the device	The pump is not screwed on tightly	Screw the pump on tightly
	O-ring on the pump is faulty	Replace the O-ring
	Diaphragm is defective	Replace the diaphragm
Liquid flows out of the pump	Valve disk dirty or defective	Clean or replace the valve disk
The nozzle does not spray even though pressure is present	Filter and / or nozzle blocked	Clean the filter or / and nozzle
Safety valves blows off too early	Safety valve is defective	Replace safety valve
The shut-off valve does not close. Liquid emerges without the lever being activated.	O-ring on the pressure bolt not greased. Defective pressure bolt or O-ring	Grease the O-ring of the pressure bolt. Replace the pressure bolt or O-ring
Pressure gage is not indicating any tank pressure.	Pressure gage defective	Sever attachments at top, at bottom, on right. Open panel, unscrew pressure gage with wrench and replace. Insert fixing knob, push to the right and insert panel

## Declaration of Conformity

WILHELMSSEN SHIPS SERVICE AS.  
Strandveien 20  
NO-1366 LYSAKER  
Norway

WILHELMSSEN SHIPS SERVICE AS. herewith declare that the below mentioned products are manufactured conform the mentioned standards and meets all requirements mentioned in those.

The brand name UNITOR is a registered trademark fully owned by Wilhelmsen Ships Service AS.

According to EC Machinery Directive 2006/42/EC, Appendix II, No. 1A. we WILHELMSSEN SHIPS SERVICE AS., declare that the products pressure spraying devices 3585 – with product number and Description :572020 UNITOR JET SPRAY UNIT 6BAR, 10 LTR STEEL,FPM- and 3615 – with product number and Description : 572085 -UNITOR JET SPRAY UNIT 6BAR, 10 LTR ST.STEEL,FPM- in the version supplied comply with all relevant provisions of the Directive 2006/42/EC.

Furthermore, the device complies with the Directive 2014/68/EU for pressure equipment.

WILHELMSSEN SHIPS SERVICE AS.

Date: 1/10/2023

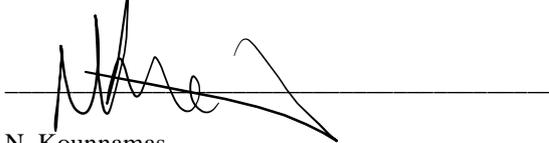

N. Kounnamas  
Head of Product Management- Cleaning

The data and illustrations in these instructions for use are for orientation only and not binding in any way. The manufacturer reserves the right to make changes or improvements to the products if these are considered appropriate without having to notify customers owning a similar model about this fact.

wilhelmsen.com

**Wilhelmsen Ships Service**

Phone: +47) 67 58 40 00

Fax: +47) 67 58 40 80

Postal Address:

PO Box 33, NO-1324

Lysaker, Norway

