

# UNITOR INSTRUCTION MANUAL

729403 HPC STATIONARY 3P

729404 HPC STATIONARY 4P

729406 HPC STATIONARY 6P

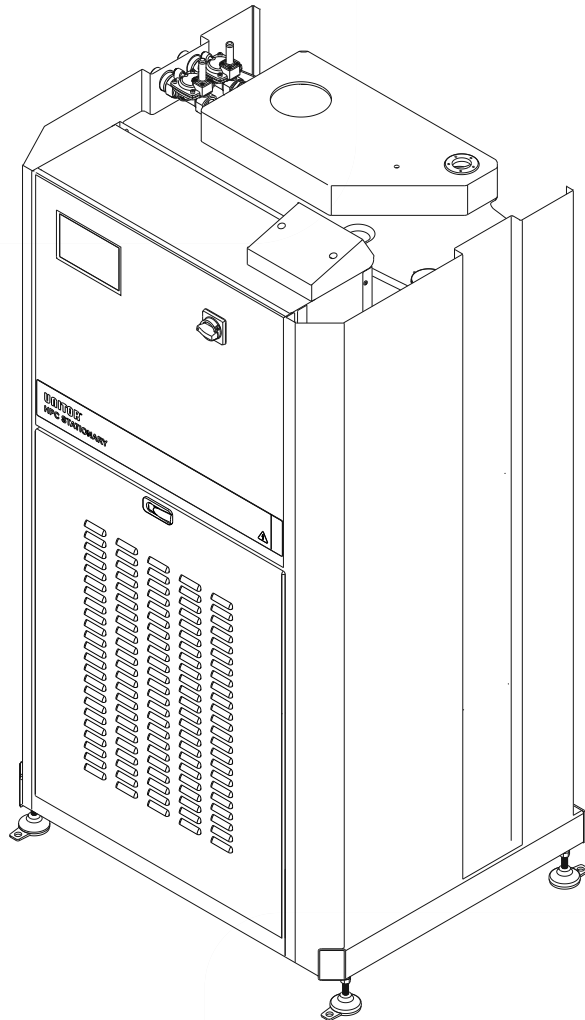

Version b 107309174

<b>EN</b>	<b>Operating instructions</b> .....	<b>7</b>
<b>DE</b>	<b>Bedienungsanweisungen</b> .....	<b>19</b>
<b>FR</b>	<b>Instructions de fonctionnement</b> .....	<b>31</b>
<b>ES</b>	<b>Instrucciones de funcionamiento</b> .....	<b>45</b>

**A**

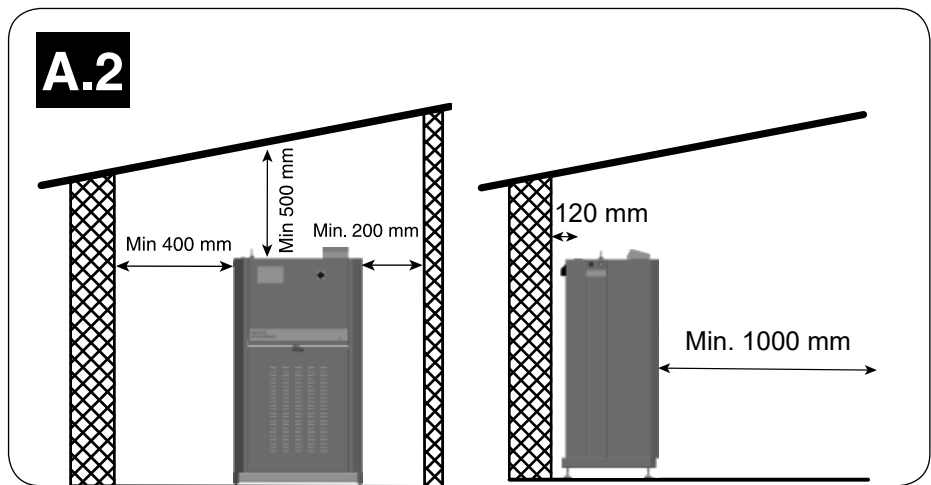
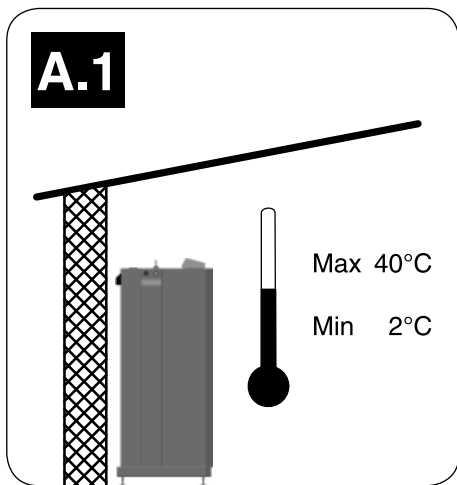
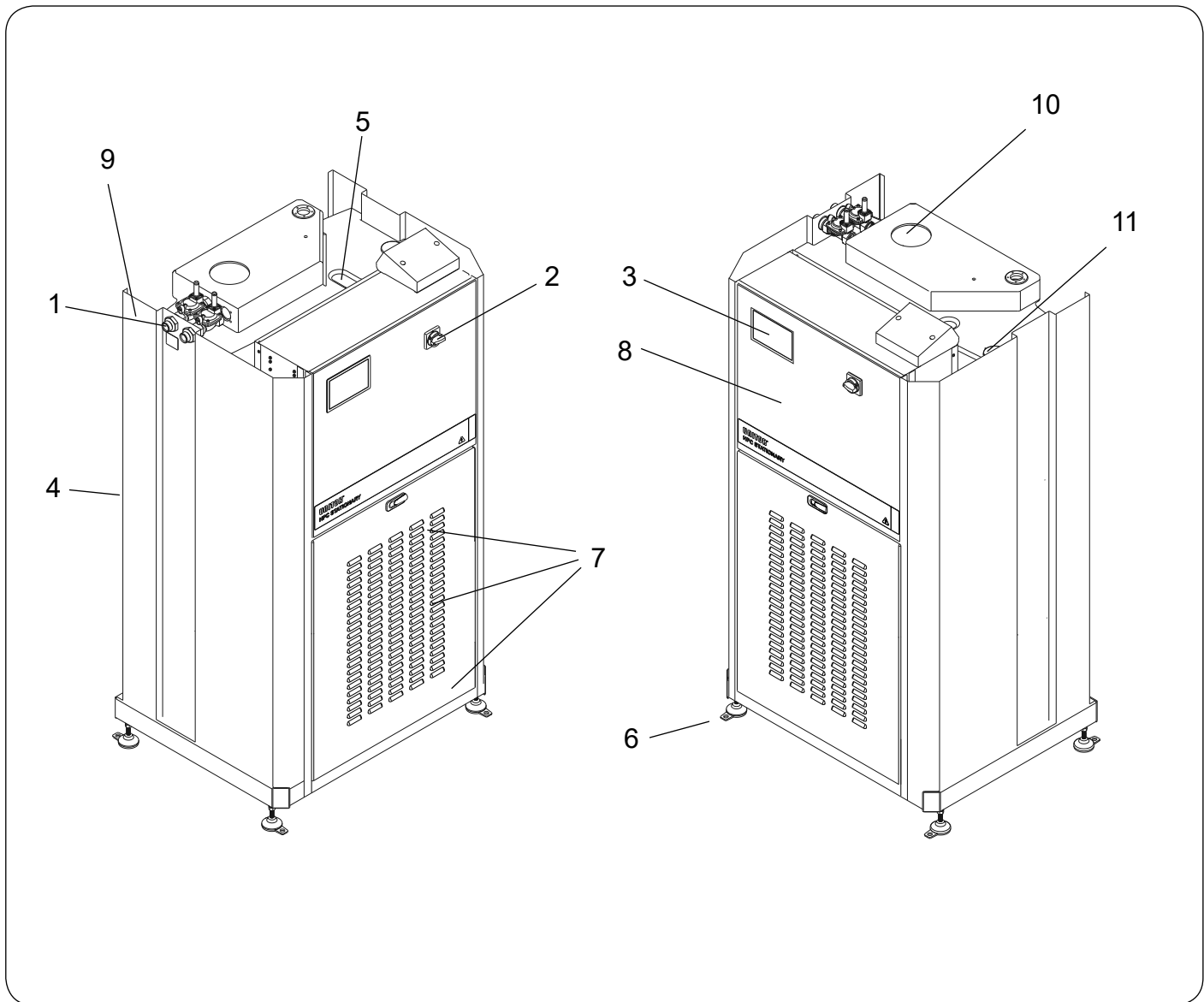

**A.3**

1

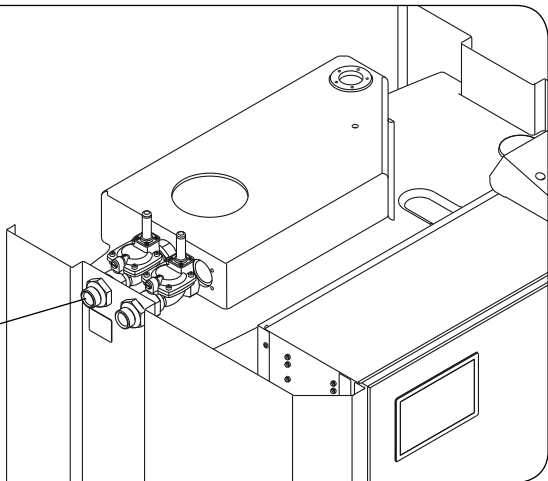

**A.3.1**

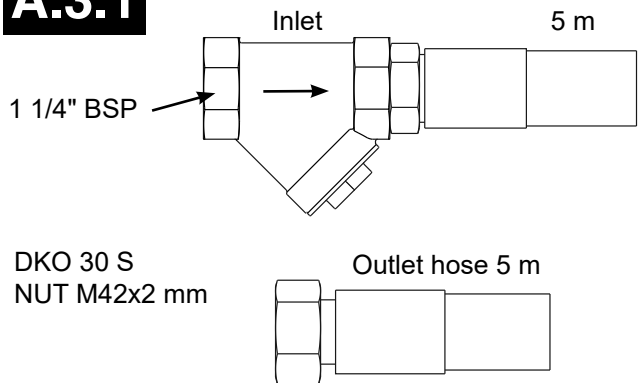

**A.4**

1

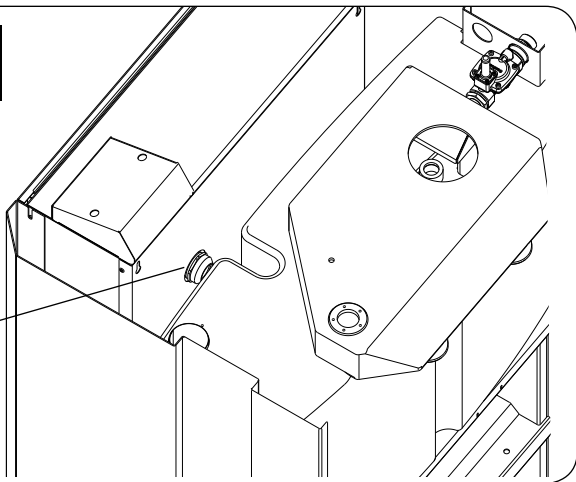

**A.5**

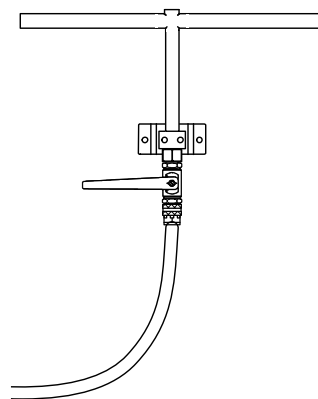

**A.6**

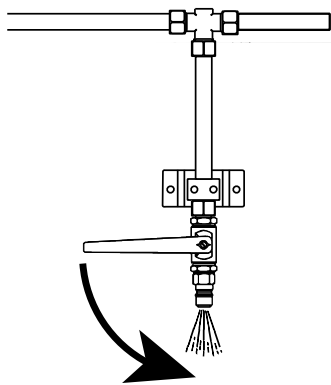

**B.1.1**

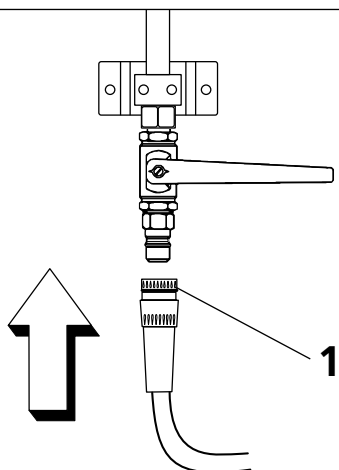

**B.1.2**

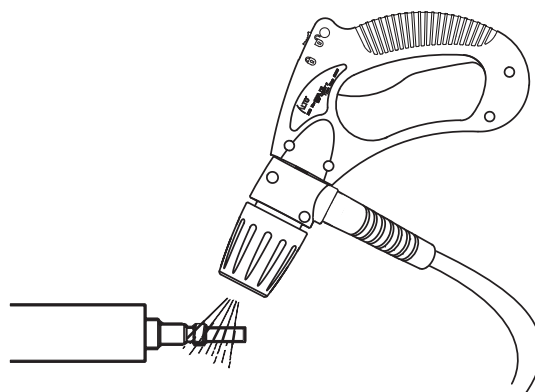
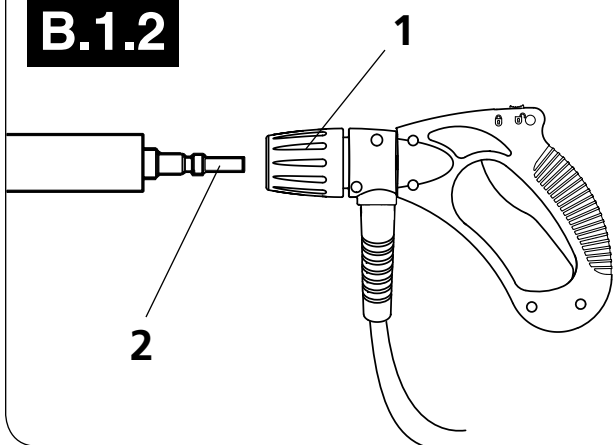

**B.1.3**

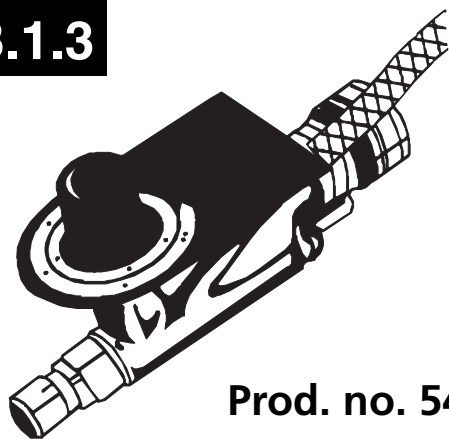

Prod. no. 545327

**B.3**

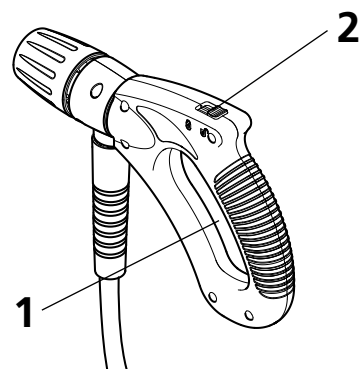

**B.5**

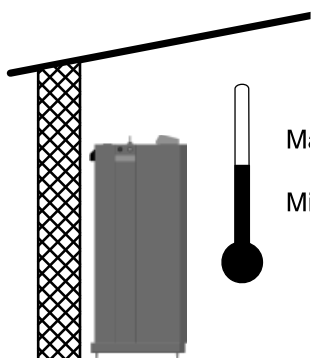

**C**

**C.1**

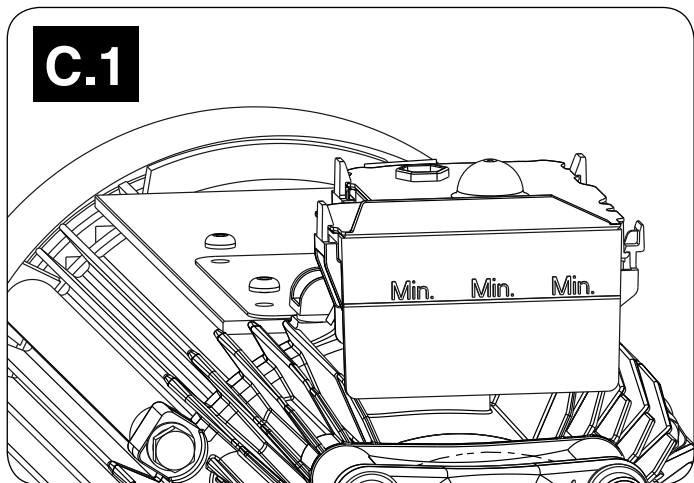

**C.2**

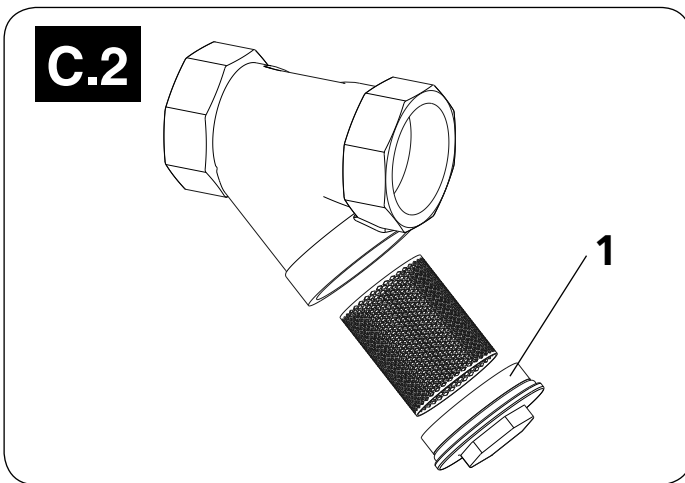

## Operating Instructions

This high pressure washer has been developed for professional use within:

- agriculture, light industry, transport, building and construction, service

Only use the high pressure washer for purposes described in this manual.

Regarding the following sections:

**A - Installation**

**B - Operation**

**C - Maintenance**

please refer to pictures in front of the manual.

### A - Installation

#### Before starting

#### DO READ SAFETY INSTRUCTIONS BEFORE USE!

The **Unitor HPC Stationary** is a flexible pump station capable of supplying several simultaneous users with pressurized cold / hot water through a pipeline. The **Unitor HPC Stationary** has been pre-adjusted for a certain line pressure which is also the maximum working pressure.

#### Operating elements:

1. Water connection with filter - hot/cold
2. Main switch
3. Display
4. Connection of pipe system
5. Electric cable, mounting
6. Adjustable feet (m12)
7. Cabinet
8. E-box
9. Type plate
10. Inspection plug, water tank
11. Filter, water tank

#### A.1 Temperature conditions

The machine should be installed in a frost-free room. This applies to pump as well as pipelines incl. of outlet points. Concerning outdoor outlet points it should be possible to close and empty that part of the line which is exposed to frost.

The machine generates heat. Please ensure sufficient ventilation so that the ambient temperature does not exceed 40°C.

1 pump generates around 1 kW heat - 6 pumps 6 kW.

#### A.2 Condition of distance

In consideration of the cooling system of the machine and the accessibility of service, there must be free wall space on both sides of the machine. To the right 200 mm at a minimum and to the left 400 mm at a minimum.

For service there must be at least 1000 mm in front of the machine and 500 mm above the machine.

#### A.3 Water connection

The water connection is made through flexible hoses connected to the water inlets (1) of the machine.

The connection can be made to a water supply network or

an internal water supply. A shut-off cock should be mounted on the water supply network in the immediate vicinity of the machine.

Max. water pressure: 10 bar

Min. water pressure: 2 bar

Max. water inlet temp.: See label on machine by the water inlet.

See A.3.1 for dimensions.

On the back side of the machine there are 2 hoses attached to the water tank. These are overflow hoses in case of a malfunction in the water tank.

The two hoses must not be blocked.

If there is a risk of running sands or other impurities in the inlet water, a sand filter (50 micron) should be mounted beyond the internal filter of the machine (for further connection data see section **Technical Specifications**).

Clean the water inlet filter once a month or as needed. See C.2.

#### A.4 Mains power connection

The power system of the **Unitor HPC Stationary** is designed in conformity with the common European standard:

EN 60204-1:2006+A1:2009: Electrical equipment of machines, Part 1: General requirements.

Power should be connected through a flexible rubber cable holding copper conductors for 3 phases and earth (PE). The minimum dimensions of the cable are determined by the power consumption of the current system (cf. data sheet), but common to all systems is the following:

Max pre-fuse:	125 A
Max core section of cable:	35 mm
Min core section of cable:	25 mm

##### A.4.1 Installation of the main power supply

- Installation of the machine should be carried out by authorized engineer

Equipment to protect the user against electrical shock, should be installed and designed to fulfil the authority requirement for the actual location of the machine, this protection can be done with fuses or Residual Current Device.

The power supply cable, minimum 4G25mm<sup>2</sup>, must be connected to the machine through the cable gland in the back of the E-box (1). The wires L1 – L2 – L3 are connected to the main switch –S1, connection points 2 – 4 – 6 on the switch, Earth wire is connected to the main earth terminal placed next to the main switch.

##### A.4.2 First activation of the main switch with connected main power supply

Before the main switch is turned on, open the E-box and check the below points.

- Measure the level of the input voltage and compare it to the machine specifications.
- Turn on the circuit breakers -F1, -F2 and -F3.
- Turn on the overload protection units for the MPU's and the frequency inverter -F4 to -F10.
- Close the E-box and turn the two locks to locked position

## SUPPLY NETWORK

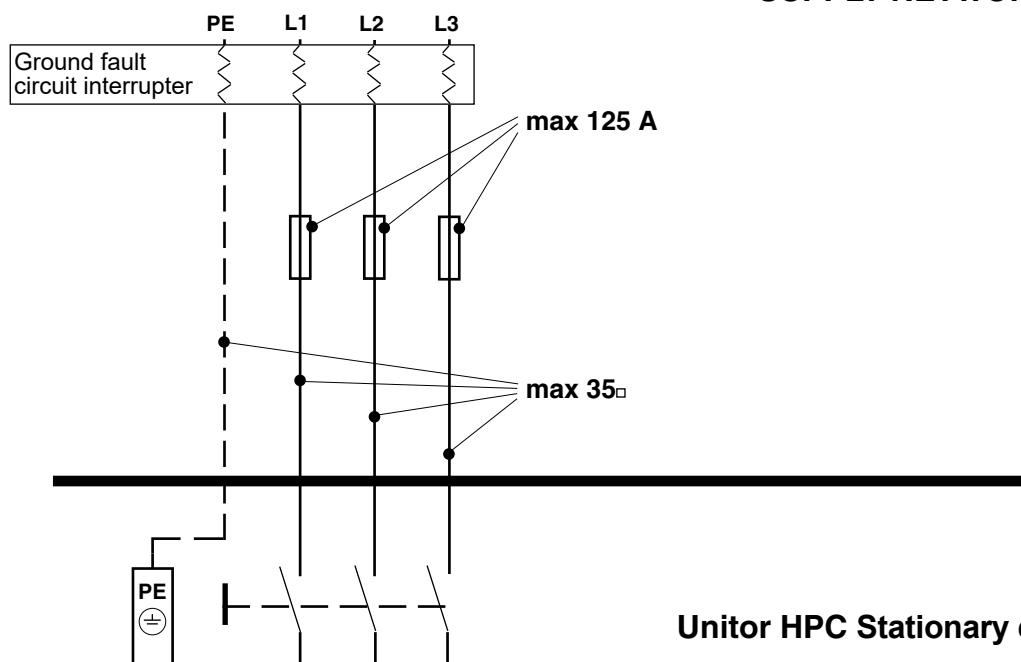

Unitor HPC Stationary control system

by using the supplied key.

### A.5 High pressure connection

**IMPORTANT:** When connecting to a pipeline always use the flexible hose connection from the outlet of the machine.

The outlet of the machine can be connected to a pipeline with fixed outlet points.

The pump station and outlet points should be placed so that the lines become as short as possible.

- The line should be arranged with as few bends as possible.
- Sometimes it may pay to split the line close to the pump station so the lengths conducting large volumes of water become as short as possible. A centre location of the pump station in relation to the outlet points would also lead to smaller pipe dimensions.
- Pipe lines should be fitted in a visual location everywhere or so that they may easily be inspected. Lines should not be incorporated in walls or floors. When leading through walls be careful not to be enclosed.
- The outlet points should be placed as close to the operation point as possible and so that a hose length preferably of 20 m is used.

It is recommended to let a service technician authorized by UNITOR prepare the pipeline. Please consult Wilhelmsen Ships Service for further information.

### A.6 Venting

Start the machine and open all high pressure cocks on the pipeline until all air has escaped. Start with the remotest high pressure cock.

Please note that the cock should be closed for a short time before opening it again. The latter is done in order to prevent the leakage stop from being activated when venting long pipelines.

**Note!** The machine may be protected with an antifreeze from the factory. If antifreeze in the machine - catch the

first litres until the fluid is clear water. Collect the water in a container for re-use.

## B - Operation

### B.1 Connections

#### B.1.1 High pressure hose on pipe system

The UNITOR high pressure hose with imprinted max. working pressure and temperature should be attached to the outlet connection of the pipe system by the quick coupling (1).

#### Danger of scalding!

Never dismount high pressure hoses at water temperatures above 50°C.

**IMPORTANT:** Prior to dismounting of the high pressure hose the machine should be stopped and the shut-off cock closed. Then activate the trigger of the spray handle to relieve the high pressure hose of pressure.

#### B.1.2 Spray handle - accessories

1. Pull forward the quick coupling trigger (1) of the spray handle.
2. Insert the nipple of the spray lance (2) in the quick coupling and release the trigger.
3. Pull forward the spray lance or any other accessory to ensure correct mounting before starting the machine.

**NOTE!** Clean nipple of any impurities each time the spray lance has been dismounted.

#### B.1.3 Application of detergents (external, only 160 bar machines)

If you want to apply detergents or disinfectants these should be dosed to the water through an injector. In conjunction with the injector it may be advantageous to use a wall rack on which spray lances, 2 pcs. of 25 l containers as well as



10 m high pressure hose can be placed.

Below you will find various types of outlet points with injectors.

### 1. Outlet point with detachable injector

To be attached to the quick coupling of the high pressure cock.

To be used for dosing of low-foaming detergents or disinfectants.

Dosage 1-8%.

### 2. Outlet point with detachable foam injector

To be attached to the quick coupling of the high pressure cock.

To be used in conjunction with foam lance for application of high-foaming detergents or disinfectants.

Dosage 1-5%.

### 3. Outlet point with cleaning trolley and foam injector

To be attached to the quick coupling of the high pressure cock.

To be used in the same way as "Outlet point with detachable foam injector".

Makes it possible to place 4 spray lances, 2 pcs. of 25 l containers as well as 20 m high pressure hose.

## B.2 Start

### B.2.1 First activation of the main switch with connected main power supply

By turning the main switch to ON position the control system will start the self-validation procedure and start up the display, please note that there is a start-up delay on the display.

In the self-validation mode, the water tank is filled up with water and all the protection circuits are checked. The green circle around the start button will flash.

If the water tank is not filled up in 4 minutes, the system will stop and the water supply needs to be checked. The water level in the water tank is shown on the display.

When the water tank is filled with water and the system is ready to start, the green circle will stop flashing.

### B.2.2 Start/stop

Press the start button on the display (FIG.1 #3) and the green circle around the button will light up.

Press the stop button on the display (FIG.1 #4) and the machine will stop and turn the green circle off.

When the start button is activated the machine will start up Motor Pump Unit (MPU) to reach the wanted pressure, it is shown on the display which MPU that is activated, the specific MPU-symbol (FIG.1 #8) lights up green. MPU's will automatically be turned on/off when output water flow is changed, and the frequency inverter will adjust the line pressure to the selected pressure. Actual line pressure is shown on the display (FIG.1 #2).

### B.2.3 Line pressure adjustment

The line pressure from the machine can be adjusted. To adjust

the pressure, push on the pressure value by the pressure adjustment tab on the display (FIG.1 #13) for 20 sec. then use the +/- tab to adjust to the wanted pressure and press OK to save the value or press cancel to undo the change. NOTE: If the pressure change is permanent, adjustment of the mechanic bypass valve is necessary.

### B.2.4 Water tank

The water level will automatically be maintained by the control system, the inlet valve symbol will light up blue on the display when the inlet valve is activated. The actual water temperature is shown on the display (FIG.1 #1).

If the Cold/Hot option is mounted on the machine the water temperature is adjusted to the selected temperature, two valves are shown on the display, one for Cold inlet water and one for Hot inlet water, when the Cold valve is activated it lights up blue and when the hot valve is activated it lights up red. To adjust the temperature, push on the temperature value by the temperature adjustment tab on the display (FIG.1 #12) for 10 sec. and use the +/- tab to adjust to the wanted temperature and press OK to save the value or press cancel to undo the change.

### B.2.5 Bypass system

When the output water flow is reduced, the bypass system will activate. When the bypass system is activated, the water will return to the water tank, the actually volume is shown on the display (FIG.1 #14), the bar light up and show the water volume, if 1/3 of the bar is blue on a 6 MPU machine, the water from two MPU's is returning to the water tank.

If more than one pump is active all the redundant pumps will stop after 8 seconds, if the outlet is completely closed the last pump will stop after 20 sec.

The machine is still active and starts up again when the line pressure drops below the start pressure.

### B.2.6 Errors and warnings.

There are two types of failures in the control system on the machine:

- **Error:** Inverter error, Critical water level, All MPU deactivated, Inlet water flow low, low output pressure, High temperature water tank, remote or display communication failure. These errors will stop the machine immediately because it is critical for the machine or connected systems.
- **Warnings:** MPU oil level low, MPU thermic high temp, MPU overload protection activated, abnormal water level in water tank, Slave #1 or #2 communication failure. These warnings won't stop the machine.

The actual warning will be shown on the Display, to reset press the affected MPU or the water tank where the warning is active and the system will validate that the warnings is gone and set the system to normal status again.

The reset is done without stopping the machine totally.

## B.2.7 Display

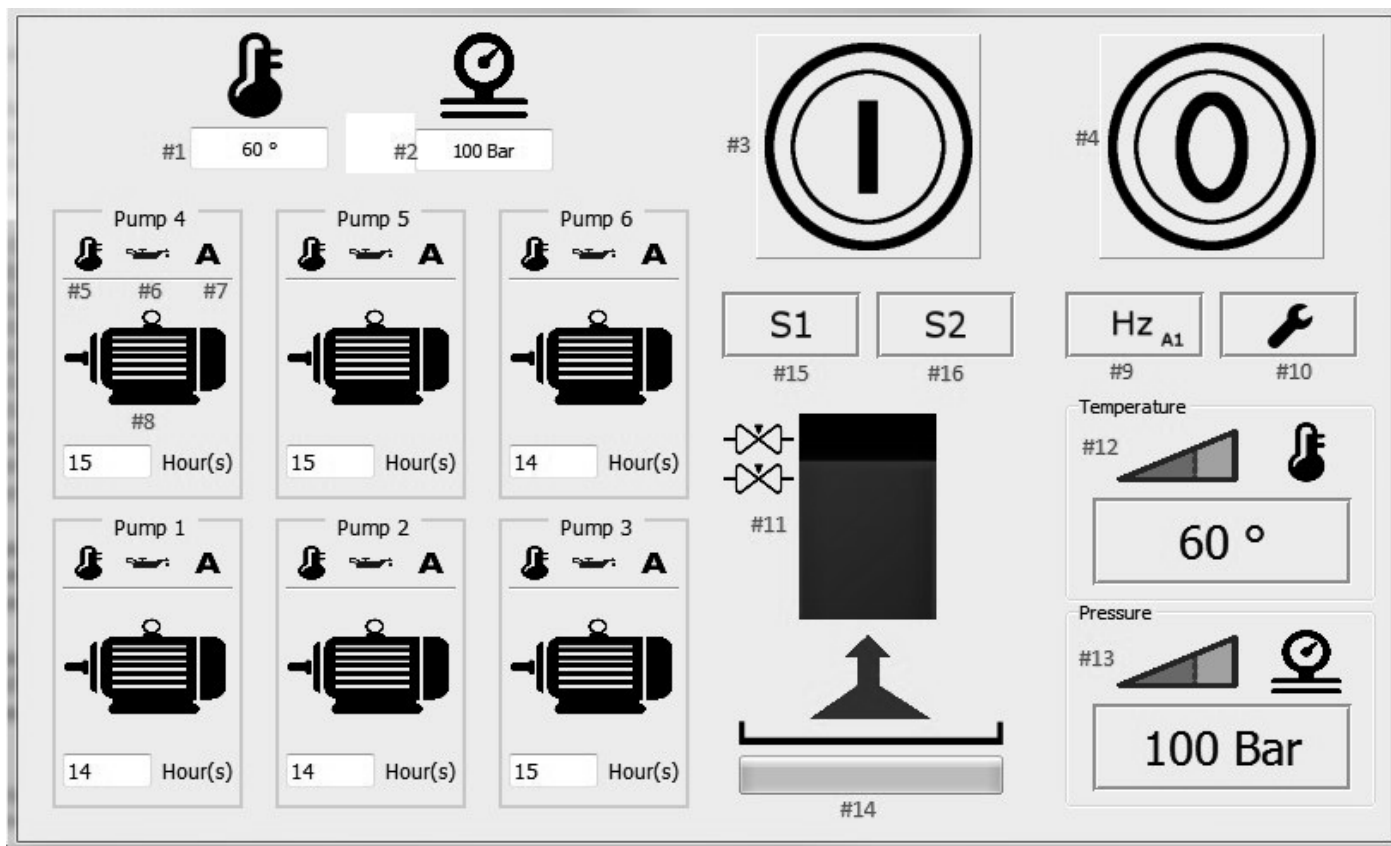
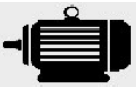

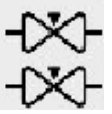



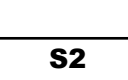

FIG. 1

Symbol	Ref #	Function	Signal	Action
	1	- Actual water temp. - Reset water temp. error	Red - water temperature error	- Check inlet water temperature - if OK, contact Service
	2	- Actual line pressure - Reset output pressure low limit (option)	Red - output pressure low limit error (option)	- Check water flow - Check available pumps
	3	- Start machine	Flash green - control system in self-validation mode. Green - machine active	
	4	- Stop machine - Reset warning / error	Flash red - system warning  Red - system error	Check below points: - MPU oil level - MPU internal heat sensor - MPU overload protection - WBT below normal level  - Inverter failure - Water level error
MPU 	5		Red - actual MPU#temperature warning	- Check air intake MPU
MPU 	6		Red - oil level low actual MPU#	- Check oil level
MPU <b>A</b>	7		Red - overload protection activated for actual MPU#	- Check power supply

Symbol	Ref #	Function	Signal	Action
MPU 	8	<ul style="list-style-type: none"> <li>- Reset warning on actual MPU</li> <li>- Hour counter actual MPU</li> </ul>	Flash red - MPU deactivated on the overload protection unit Green - MPU activated Highlighted square when reset is possible	<ul style="list-style-type: none"> <li>- Before reset please make sure that the problem is solved</li> </ul>
HZ <sub>A1</sub> 	9		Flash red - warning on inverter MPU (oil, temp., overload) Red - inverter failure	<ul style="list-style-type: none"> <li>- Check MPU where the failure is down</li> <li>- Contact service</li> </ul>
Water tank 	10	<ul style="list-style-type: none"> <li>- Service functions</li> </ul>	Flash blue - 20 hours or less to next service Blue - service needed	<ul style="list-style-type: none"> <li>- Contact service</li> </ul>
Temp. 	11	<ul style="list-style-type: none"> <li>- Reset low water level warning</li> </ul>	Water tank square symbol: Blue - normal water level Yellow - warning water level Red - Critical water level  Water inlet Valves: Blue - Cold water inlet open Red - Hot water inlet open	<ul style="list-style-type: none"> <li>- Check water supply</li> <li>- Check water filter</li> <li>- Check water supply</li> <li>- Check water filter</li> </ul>
Pressure 	12	<ul style="list-style-type: none"> <li>- Adjust water tank temperature</li> <li>- Press the value (60°C) for 10 sec. to open the adjustment window</li> </ul>		
Backflow bar 	13	<ul style="list-style-type: none"> <li>- Adjust the line pressure.</li> <li>- Press the value (100) for 20 sec. to open the adjustment window</li> </ul>		
S1 	14		Blue - the bar will be coloured to show the amount of water that flows back to the water brake tank. If 1/3 of the bar is blue on a 6 MPU machine, it means that 2 MPUs are bypassing water.	
S1	15		Red - failure on the 1. Slave machine. Only with master/slave machines	<ul style="list-style-type: none"> <li>- Check the UI Display on the 1. Slave machine to see the actual failure</li> </ul>
S2	16		Red - failure on the 2. Slave machine. Only with master/slave machines	<ul style="list-style-type: none"> <li>- Check the UI Display on the 2. Slave machine to see the actual failure</li> </ul>

### B.3 Operation - automatic start/stop

#### Always hold the spray lance with both hands!

The machine is automatically activated when the trigger (1) of the spray handle is activated.

When the trigger is released, the machine automatically stops after 20 seconds.

When the machine is not in use, the trigger should be locked with locking device (2).

### B.4 Stop

#### Danger of scalding!

Never detach high pressure hoses at a water temperature

above 50°C.

Never detach the high pressure hose while the machine is in operation.

1. To stop the machine, push the red stop button (#4) and turn the main switch (2) to position - 0 -.

### B.5 Frost protection

The machine should be installed in a frost-free room. This applies to pump as well as pipelines incl. of outlet points. Concerning outdoor outlet points it should be possible to empty that part of the line which is exposed to frost.

**IMPORTANT:** For safety reasons, hoses, spray lances and other accessories should always be thawed prior to use.

## C - Maintenance

It applies to the most exposed components that a minimum of maintenance ensures a prolonged and problem-free operation. Therefore it will be a good idea to make a habit of the following:

### Maintenance Schedule

	Weekly	After the first 50 operating hours	Every six months or 500 operating hours	As required
Checking pump oil level	●			
Changing pump oil			●	
Cleaning water filter	●			●

Prior to attaching the water hose and the high pressure hose, the quick couplings should be cleaned of dust and sand.

Prior to attaching the spray lance or other accessories to the spray handle, the machine should be started and the quick coupling cleaned of dust and sand.

### C.1 Oil

Check the oil level in the oil glass.

If the oil level gets too low, the pump will automatically shut down and #6 will light up.

In the case of repeated low oil level (oil waste) please stop operation and contact your Wilhelmsen Ships Service representative.

### PROTECT THE ENVIRONMENT

Waste oil and oil sludge must be removed as laid down in the instructions.

### C.2 Water filter

To avoid debris entering the high pressure pump, a water filter (fine) is fitted at the water inlet. Dependent on the purity of the water, this filter will have to be cleaned at regular intervals.

The filter can be removed when the plug (pos. 1) has been unscrewed.

There is also a filter in the tank (pos. 11). This filter can be removed by dismantling the two screws (torx 20).

Pull the filter up and out of the water tank. Clean the filter and remount it.

### C.3 Cleaning of high pressure nozzle

A clogging up in the nozzle causes bad cleaning, and a cleaning of the nozzle is immediately required.

1. Stop the machine and detach the spray lance.
2. Clean the nozzle.  
**IMPORTANT:** ONLY use the cleaning tool when the spray lance is detached.
3. Flush the spray lance backwards with water.
4. If the pressure is still too high, repeat items 1-3.

### C.4 Disposable waste

This high pressure washer consists of parts which can affect the environment when thrown away. Parts that can pollute are as follows:

Oil, painted/zinc-coated parts, plastics/plastic-coated parts.

Therefore, it is important to follow the laws concerning the removal of polluting and dangerous materials when replacing spare parts or disposing of high pressure washer.

It is recommended that you bring the rejected parts to waste disposal areas or recycling plants that are approved for the destruction of these types of materials.

## Troubleshooting

You have chosen the best quality and therefore deserve the best service. To avoid unnecessary disappointments, you should check the following before contacting your Wilhelmsen Ships Service representative.:

Symptom	Reason	Action
<b>Machine/pump will not start</b>	<ul style="list-style-type: none"> <li>&gt; A fuse has blown</li> <li>&gt; Power/plug not connected</li> <li>&gt; Thermal switches in motor activated (red lamp flashes) #5</li> <li>&gt; Thermal relay switched off (red lamp flashes) #5</li> <li>&gt; Oil shortage in pump #6</li> </ul>	<ul style="list-style-type: none"> <li>• Change the fuse.</li> <li>• Connect power/plug.</li> <li>• Let the motor cool. Start the machine and check that the working pressure is not too high and that the mains voltage corresponds to the specifications.</li> <li>• Refill with oil.</li> </ul>
<b>Fuses blow</b>	<ul style="list-style-type: none"> <li>&gt; Installation does not correspond to the ampere consumption of the machine</li> </ul>	<ul style="list-style-type: none"> <li>• Change to an installation corresponding to the ampere consumption of the machine at a minimum. Replace the fuse.</li> </ul>
<b>Working pressure too low</b>	<ul style="list-style-type: none"> <li>&gt; Nozzle worn</li> <li>&gt; Wrong spray lance</li> <li>&gt; Too many users on the system</li> <li>&gt; Reduction valve of spray lance not adjusted to max. pressure.</li> <li>&gt; Nozzle partly clogged up</li> </ul>	<ul style="list-style-type: none"> <li>• Replace the nozzle.</li> <li>• Replace the spray lance.</li> <li>• Turn reduction valve completely counter-clockwise.</li> <li>• Clean the nozzle (see section C.3).</li> </ul>
<b>Working pressure not steady</b>	<ul style="list-style-type: none"> <li>&gt; Water temperature too high</li> <li>&gt; Insufficient water supply to pumps</li> <li>&gt; Air in the system</li> <li>&gt; Water filters clogged up</li> </ul>	<ul style="list-style-type: none"> <li>• Lower the temperature of the inlet water to max. temperature (<b>see Technical Specifications</b>).</li> <li>• Check water inlet filter + filter in water tank. If that does not solve the problem, the water supply for the machine is insufficient.</li> <li>• Vent the system (see section A.7).</li> <li>• Clean filters (see sect. C.2)</li> </ul>
<b>No working pressure</b>	<ul style="list-style-type: none"> <li>&gt; Nozzle clogged up</li> <li>&gt; No inlet water</li> <li>&gt; High pressure cock of outlet point open.</li> </ul>	<ul style="list-style-type: none"> <li>• Clean nozzle (see sect. D.3)</li> <li>• Check that the shut off cock of the water inlet is open. Check that the water supply meets the requirements (see section A.4)</li> <li>• Close all high pressure cocks not in use.</li> </ul>
<b>Machine/pumps start and stop</b>	<ul style="list-style-type: none"> <li>&gt; Leaky hose/ pipeline/spray handle</li> </ul>	<ul style="list-style-type: none"> <li>• Repair leak.</li> </ul>

Should other malfunctions occur than those mentioned above, please contact your Wilhelmsen Ships Service representative.

Machine failure - see B2.6 and B2.7.

## Warranty

Your UNITOR product is guaranteed for 12 months from date of purchase (purchase receipt must be presented) on the following conditions:

- that defects are attributable to flaws or defects in materials or workmanship. (Usual wear and tear as well as misuse are not covered by the guarantee).
- that repairs have not been carried out or attempted by other than UNITOR-trained service staff.
- that only original accessories have been applied.
- that the product has not been exposed to abuse such as knocks, bumps or frost.
- that the instructions in the manual have been carefully observed.

A warranty repair comprises the replacement of defective parts, but it does not cover freight and packaging charges. Besides we refer to national Sale of Goods Act.

Any **illegitimate** guarantee repair will be invoiced. (I.e. malfunctions due to **causes** mentioned in section **“Troubleshooting”** of the instruction manual).

## CE Declaration of Conformity

We,

Wilhelmsen Ships Service  
Strandveien 20  
N-1366 Lysaker  
Norway

Hereby solely declare, that the

Products: HPW - Professional - Stationary  
Description: 440V, 3~, IPX5  
Type: Unitor HPC Stationary 3/4/6

are in compliance with the following standards:

EN 60335-1:2012+A11:2014  
EN 60335-2-79:2012  
EN 60204-1:2006+A1:2009  
EN 55014-1:2006+A1:2009+A2:2011  
EN 55014-2:2015  
EN 61000-3-2:2014  
EN 61000-3-11:2000

Following the provisions of:

2006/42/EC  
2014/30/EU  
2000/14/EC – Conformity assessment procedure according to Annex V.

















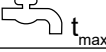
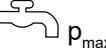
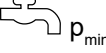
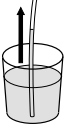

- Measured sound power level: 84-87 dB(A)
- Guaranteed sound power level: 100-103 dB(A)

















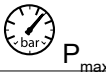

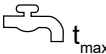
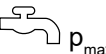
Lysaker, 18-10-2017

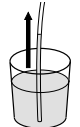

Ir. E.G.Scheepers  
Sr. Technical Product Manager

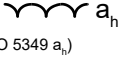
## Specifications

			HPC 3	HPC 4	HPC 6
1			UNITOR		
2		V/ph/Hz	440V/3ph/60Hz		
3		A	44	58	87
4		kW	27	35	53
5	 P <sub>IEC</sub>	bar (MPa)	200 (20)		
6	 Q <sub>IEC</sub>	l/h	3800	5100	7700
7	 P <sub>max</sub>	bar (MPa)	250 (25)		
8	 Q <sub>max</sub>	l/h	4000	5350	8100
9	 t <sub>max</sub>	°C (°F)	70 (158)		
10	 p <sub>max</sub>	bar (MPa)	10 (1)		
11	 p <sub>min</sub>	bar (MPa)	2 (0.2)		
12		m	0		
13		mm	970x1050x1800		
14	 kg	kg	349	408	526
15	 L <sub>PA</sub> <small>(IEC 60335-2-69)</small>	dB(A)+/-2	84	85	87
16	 L <sub>WA</sub> <small>(IEC 60335-2-69)</small>	dB(A)+/-2	100	101	103
17	 a <sub>h</sub> <small>(ISO 5349 a<sub>h</sub>)</small>	m/s <sup>2</sup>	<1.5+/-1		
18		N	27-122		
19		L	0.81 (x3)	0.81 (x4)	0.81 (x6)
20	 TYPE		Castrol Alphasyn T150		
21			0650 (Min. 0350)		

1			<b>EN:</b> Country variant. <b>DE:</b> Ländervarianten. <b>FR:</b> Selon le pays. <b>ES:</b> Dependende del país.
2		V/ph/Hz	<b>EN:</b> Possible voltage. <b>DE:</b> Mögliche Spannung. <b>FR:</b> Tension autorisée. <b>ES:</b> Tensión admitida.
3		A	<b>EN:</b> Fuse. <b>DE:</b> Sicherung. <b>FR:</b> Fusible. <b>ES:</b> Fusible.
4		kW	<b>EN:</b> Power rating. <b>DE:</b> Nennleistung. <b>FR:</b> Puissance nominale. <b>ES:</b> Potencia nominal.
5		bar (MPa)	<b>EN:</b> Working pressure. <b>DE:</b> Arbeitsdruck. <b>FR:</b> Pression de service. <b>ES:</b> Presión de trabajo.
6		l/h	<b>EN:</b> Water flow. <b>DE:</b> Wasserdurchsatz. <b>FR:</b> Débit d'eau. <b>ES:</b> Flujo de agua.
7		bar (MPa)	<b>EN:</b> Max. water pressure. <b>DE:</b> Max Wasserdruk. <b>FR:</b> Pression d'eau maximale. <b>ES:</b> Presión máxima de entrada del agua.
8		l/h	<b>EN:</b> Water flow <b>DE:</b> Wasserdurchsatz. <b>FR:</b> Débit d'eau. <b>ES:</b> Flujo de agua.
9		°C (°F)	<b>EN:</b> Max water inlet temperature, Intake-Pressure operation. <b>DE:</b> Max Wassereinlasstemperatur - Druckbetrieb. <b>FR:</b> Température max. de l'entrée d'eau en mode admission/pression. <b>ES:</b> Temperatura y presión máxima de entrada del agua.
10		bar (MPa)	<b>EN:</b> Max. water inlet pressure. <b>DE:</b> Max. Wassereinlassdruck. <b>FR:</b> d'eau en mode admission/pression. <b>ES:</b> Presión máxima de entrada del agua.
11		bar (MPa)	<b>EN:</b> Min. water inlet pressure. <b>DE:</b> Min. Wassereinlassdruck. <b>FR:</b> d'eau en mode admission/pression Min. <b>ES:</b> Presión mínima de entrada del agua.
12		m	<b>EN:</b> Max dry suction height. <b>DE:</b> Max. Trockensaughöhe. <b>FR:</b> Hauteur d'aspiration à sec max. <b>ES:</b> Altura máxima de succión en seco.
13		mm	<b>EN:</b> Dimensions LxWxH. <b>DE:</b> Masse LxBxH. <b>FR:</b> Dimensions l x p x h. <b>ES:</b> Dimensiones l x a x al.
14		kg	<b>EN:</b> Weight. <b>DE:</b> Gewicht. <b>FR:</b> Poids du nettoyeur. <b>ES:</b> Peso del limpiador.
15		dB(A) +/-2	<b>EN:</b> Sound pressure level $L_{PA}$ . <b>DE:</b> Schalldruckpegel. <b>FR:</b> Niveau de pression acoustique. <b>ES:</b> Nivel de presión sonora.
16		dB(A) +/-2	<b>EN:</b> Sound power level $L_{WA}$ . <b>DE:</b> Schalleistungspegel. <b>FR:</b> Niveau de puissance acoustique. <b>ES:</b> Potencia acústica.
17		m/s <sup>2</sup>	<b>EN:</b> Vibration. <b>DE:</b> Vibrationen <b>FR:</b> Vibration <b>ES:</b> Vibración
18		N	<b>EN:</b> Recoil forces, lance. <b>DE:</b> Rückstoßkraft, Sprührohr. <b>FR:</b> Forces de recul, lance. <b>ES:</b> Fuerzas de retroceso, lanza.
19		L	<b>EN:</b> Oil quantity. <b>DE:</b> Ölmenge. <b>FR:</b> Quantité d'huile. <b>ES:</b> Cantidad de aceite.
20			<b>EN:</b> Oil type. <b>DE:</b> Öltyp. <b>FR:</b> Type d'huile. <b>ES:</b> Tipo de aceite.
21			<b>EN:</b> Nozzle size. <b>DE:</b> Düsengrösse. <b>FR:</b> Taille de la buse. <b>ES:</b> Tamaño de la boquilla
<b>EN:</b> Specifications and details are subject to change without prior notice. <b>DE:</b> Technische Daten und Details des Geräts können sich ohne vorherige Ankündigung ändern. <b>FR:</b> Ces spécifications et détails sont susceptibles d'être modifiés sans préavis. <b>ES:</b> Las especificaciones y los datos están sujetos a cambios sin previo aviso.			



## OPERATIONAL EFFICIENCY

### Wilhelmsen Ships Service

Postal address	Visiting address
P.O. Box 33	Strandveien 20
N-1324 Lysaker	N-1366 Lysaker
Norway	Norway

T (+47) 67584550

F (+47) 67584570

E [wss.info@wilhelmsen.com](mailto:wss.info@wilhelmsen.com)

[www.wilhelmsen.com/shipsservice](http://www.wilhelmsen.com/shipsservice)

