

TILBAKESLAGSVENTIL M/KLAFF OG FJÆR, TYPE ZRKF-AB-DU

Swing check valve with flap and spring, type ZRKF-AB-DU



Dimensjoner

DN 32 – DN 300

Trykkklasse

PN 16

Temperaturområde

-10°C til +90°C

Anvendelsesområde

Sjøvannsanlegg.
Tåler olje.

Materialbeskrivelse

Hus	Bronze (CC333G)
Klaff	Superduplex (1.4469)
Fjær	Legering C4 (2,4610)
Pakning	NBR

Dimensions

DN 32 – DN 300

Pressure range

PN 16

Temperature range

-10°C to +90°C

Range of applications

Seawater plant.
Tolerates oil.

Materials

Body	Bronze (CC333G)
Flap	Superduplex (1.4469)
Feather	Hastelloy C4 (2,4610)
Packing	NBR

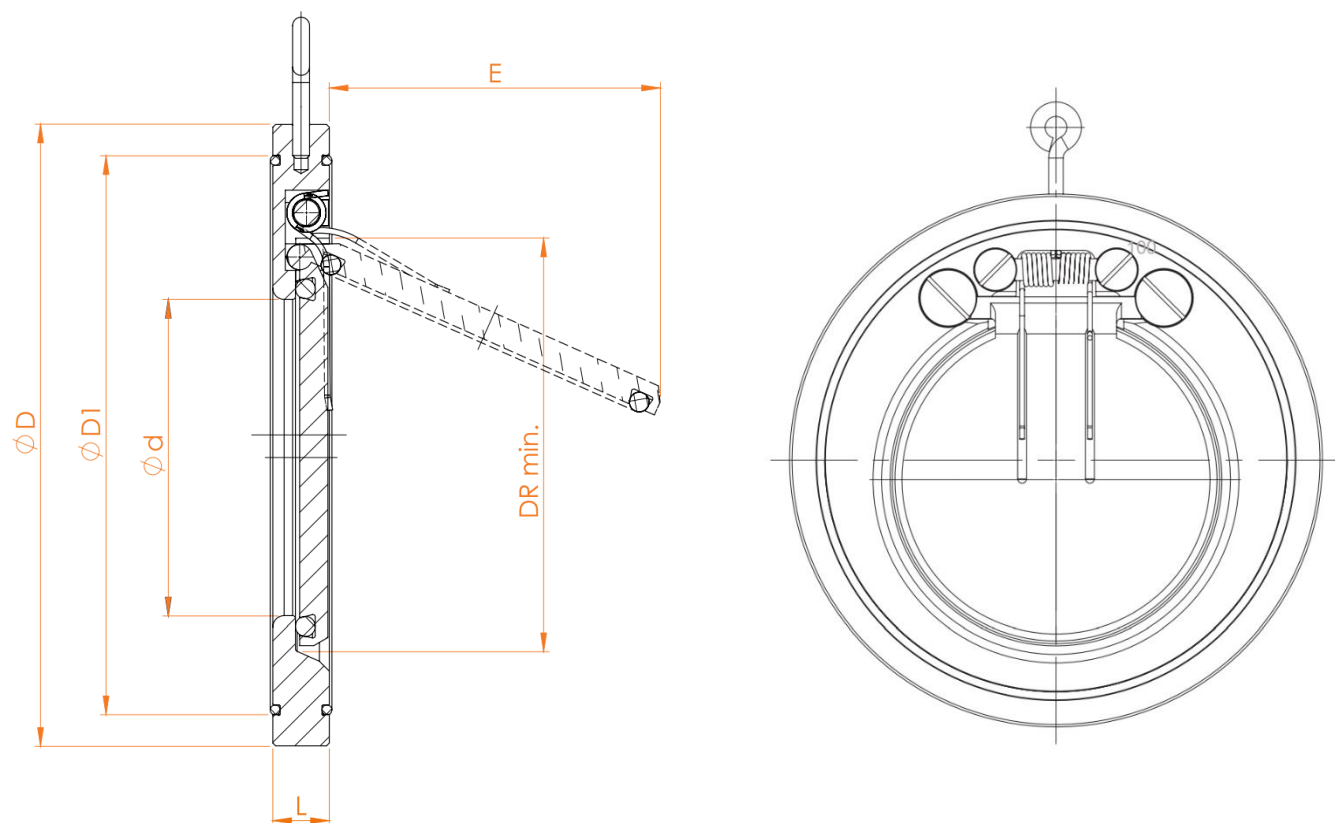
MÅLTABELL OG ARTIKKELNUMMER/MEASUREMENTS AND PART NO.

DN	L	$\varnothing d$	$\varnothing D1$	E	DR min.	KG	NRF nr./Part No.
32	15	18	59	22	37	0,67	5551703
40	16	22	72	25	43	0,85	5551704
50	14	32	86	37	54	0,91	5551705
65	14	40	109	50	70	1,23	5551706
80	14	54	119	61	82	1,5	5551707
100	18	70	146	77	106	2,42	5551708
125	18	92	173	98	131	3,34	5551709
150	20	112	197	120	159	4,61	5551711
200	22	154	255	160	207	7,68	5551712
250	26	192	312	190	260	13,4	5551713
300	32	227	363	220	309	21	5551714

Pressure-loss Diagram type ZRKF
 Pressure-loss Diagram type ZRKF

