

# Victaulic® VicFlex™ Sprinkler Fittings: Style AB6 Bracket Assembly with Models V33, V36, or V40 Dry Sprinklers

## ⚠ WARNING



- Read and understand all instructions before attempting to install any Victaulic products.
- Always verify that the piping system has been completely depressurized and drained immediately prior to installation, removal, adjustment, or maintenance of any Victaulic products.
- Confirm that any equipment, branch lines, or sections of piping that may have been isolated for/ during testing or due to valve closures/positioning are identified, depressurized, and drained immediately prior to installation, removal, adjustment, or maintenance of any Victaulic products.
- Wear safety glasses, hardhat, and foot protection.

Failure to follow these instructions could result in death or serious personal injury and property damage.

- This Victaulic® VicFlex™ product shall be used only in fire protection systems that are designed and installed in accordance with current, applicable National Fire Protection Association (NFPA 13, 13D, 13R, etc.) standards, or equivalent standards, and in accordance with applicable building and fire codes. These standards and codes contain important information regarding protection of systems from freezing temperatures, corrosion, mechanical damage, etc.
- These installation instructions are intended for an experienced, trained installer. The installer shall understand the use of this product and why it was specified for the particular application.
- The installer shall understand common industry safety standards and potential consequences of improper product installation.
- It is the system designer's responsibility to verify suitability of stainless steel flexible hose for use with the intended fluid media within the piping system and external environment.
- The material specifier shall evaluate the effect of chemical composition, pH level, operating temperature, chloride level, oxygen level, and flow rate on stainless steel components to confirm system life will be acceptable for the intended service.

Failure to follow installation requirements and local and national codes and standards could compromise system integrity or cause system failure, resulting in death or serious personal injury and property damage.

### Flexible Hose Listing and Approval Information

Flexible Hose	UL LISTED	FM APPROVED
AH2	With AB6	With AB6
AH2-CC	With AB6	With AB6

**NOTE:** Flexible hoses are available in lengths from 31 - 72 inches/787 - 1829 mm.

### Maximum Working Pressure Rating of Flexible Hose:

175 psi/12 Bar/1207 kPa

### Maximum Ambient Temperature Rating of Style AB6 Bracket Assembly:

150° F/66° C

225° F/107° C for Optional Silicone Seal – **NOTE:** The optional silicone seal cannot be used with panel configurations that have corrugation heights greater than 1/8 inch/3.2 mm.

### Connection to Sprinkler Piping:

- 1 inch/DN25 NPT/BSPT
- 1 inch/DN25 IGS

### Maximum Number of 90° Bends Per Flexible Hose:

Refer to the "Friction Loss Data" section

### Flexible Hose Bend Characteristics:

**NOTE:** Care shall be taken to avoid torquing the flexible hose.

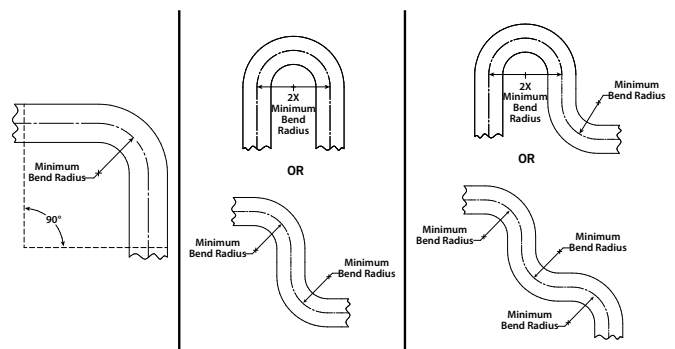

SCAN QR CODE FOR ACCESS TO THE FULL I-VICFLEX.BRG BEND RADIUS GUIDE INSTRUCTIONS ON VICTAULIC.COM

## INTRODUCTION

The Style AB6 Bracket Assembly consists of a V33, V36, or V40 Dry Sprinkler with additional mounting components and shall be installed only in applications where the minimum thickness of the ceiling or wall is 3 inches/76 mm and the strength and structure of the ceiling or wall is comparable to or stronger than thin-clad aluminum freezer panel.

Refer to Victaulic publication 10.90 for details regarding Style AB6 Bracket Assembly weights. The ceiling or wall shall be designed to support the load of the Style AB6 Bracket Assembly. Victaulic publication 10.90 can be downloaded at [victaulic.com](http://victaulic.com).

## IMPORTANT INSTALLATION INFORMATION

- Victaulic® VicFlex™ products shall be installed in accordance with current, applicable National Fire Protection Association (NFPA 13, 13D, 13R, etc.) standards, or equivalent standards, and in accordance with applicable building and fire codes. Victaulic® VicFlex™ products are intended to be installed in wet, dry, or preaction actuated systems. Deviations from these standards or alterations to Victaulic® VicFlex™ products or sprinklers will void any Victaulic warranty and will impact system integrity. Installations shall meet the provisions of the local authority having jurisdiction and local codes, as applicable, and shall comply with all design specifications.
- Victaulic® VicFlex™ Sprinkler Fittings and/or the Style AB6 Bracket Assembly shall not be intermixed with other manufacturer's flexible sprinkler products.
- **Refer to the specific Victaulic product publication for applications and listing information. In addition, when installing Victaulic FireLock® Automatic Sprinklers with Victaulic® VicFlex™ Sprinkler Fittings, refer to the I-40 Installation and Maintenance Instructions for details on sprinkler installation requirements. Product publications and installation instructions can be downloaded at [victaulic.com](http://victaulic.com).**
- Size the piping system to meet or exceed the minimum required flow rate for the sprinkler system.
- Per NFPA requirements, flush the system to remove foreign material. Continue to flush the system until water runs clear.
- **DO NOT** install sprinkler system piping through heating ducts.
- **DO NOT** connect sprinkler system piping to domestic hot water systems.
- **DO NOT** allow electrical wiring or other cabling to be hung or wrapped around the sprinkler piping system.
- **DO NOT** install sprinklers and sprinkler fittings where ambient conditions may fall below or exceed the maximum listed or approved temperature ratings.

- The flexible hose shall not be bent or fluctuated up-and-down or side-to-side when pressurized.
- Victaulic VicFlex Series AH2 and AH2-CC flexible hoses may be painted or coated, provided that the paint or coating is compatible with stainless steel material. Care shall be taken to ensure that the sprinkler and associated components are not painted.
- **Flexible hose and fittings have limited flexibility\* and are intended only to be installed with bends not less than their respective minimum bend radii. DO NOT install flexible hose in a straight configuration.**
- Protect wet piping systems from freezing temperatures.
- If construction is altered, the building owner or their representative is responsible for referencing applicable standards to determine if additional sprinklers or other system adjustments are required.
- The building owner or their representative is responsible for maintaining the fire protection system in proper operating condition.
- After installation is complete, the entire sprinkler system shall be tested in accordance with applicable standards (NFPA 13, NFPA 25, etc.) that describe the care and maintenance of sprinkler systems. In addition, the authority having jurisdiction may have additional maintenance, testing, and inspection requirements that shall be followed. **NOTE:** A successful test is not a substitute for proper system installation and maintenance.

### **WARNING**

- Relocation of Victaulic® VicFlex™ products **SHALL** be performed by qualified personnel familiar with the system's original design criteria, sprinkler listings/approvals, and state and local codes (including NFPA 13 standards).

Failure to relocate this Victaulic® VicFlex™ product properly could affect its performance during a fire, resulting in death or serious personal injury and property damage.

\* Reference UL 2443: Section 25.1

## FLEXIBLE HOSE ASSEMBLY DRAWINGS

Refer to page 11 of this manual for flexible hose technical data.

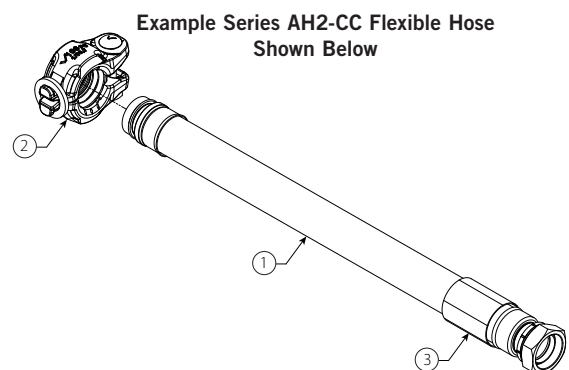
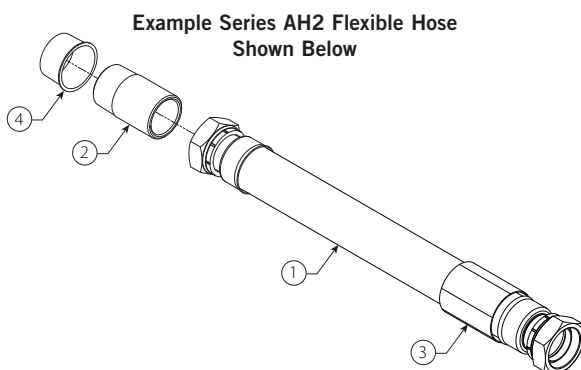

Item	Example Series AH2 Description	Example Series AH2-CC Description
1	Flexible Hose Assembly	Flexible Hose Assembly
2	Adapter Nipple	Coupling Assembly
3	Identification Sleeve	Identification Sleeve
4	Shipping Cap	-

## TECHNICAL DATA FOR MODELS V33, V36, AND V40 DRY SPRINKLERS

For technical information regarding the Model V33, V36, or V40 Dry Sprinkler, refer to Victaulic publication 10.90, which can be downloaded at victaulic.com. **NOTE:** The graphic shown below is an example of a typical sleeve and skirt configuration.

### NOTICE

- The following table is used when the ambient temperature is maintained at 40°F/4°C minimum around the wet piping system.

#### Temperature Maintained at 40°F/4°C Minimum\*

Ambient Temperature Exposed to Discharge End of Sprinkler	"D" Freezer Ceiling or Wall Thickness	"A" Order Length
Down to 20°F Down to -6.7°C	3 – 6 inches/76 – 152 mm	12 inches/305 mm
	7 – 12 inches/178 – 305 mm	18 inches/457 mm
19°F to 0°F -7.2°C to -17.8°C	3 – 6 inches/76 – 152 mm	18 inches/457 mm
	7 – 12 inches/178 – 305 mm	24 inches/610 mm
-1°F to -20°F -18.3°C to -28.9°C	3 – 6 inches/76 – 152 mm	24 inches/610 mm
	7 – 12 inches/178 – 305 mm	30 inches/762 mm
-21°F to -30°F -29.4°C to -34.4°C	3 – 6 inches/76 – 152 mm	24 inches/610 mm
	7 – 12 inches/178 – 305 mm	30 inches/762 mm
-31°F to -40°F -35.0°C to -40.0°C	3 – 6 inches/76 – 152 mm	24 inches/610 mm
	7 – 12 inches/178 – 305 mm	30 inches/762 mm

**NOTE:** Exposed minimum barrel lengths are inclusive up to 30-mph/48-kph wind velocities

\* Refer to Victaulic publication 10.90 for additional tables that cover temperatures other than 40°F/4°C Minimum

#### Product Marking Information

UL 2443 Model Designation	Outlet Fitting Mark	Description
AH2-XX	N/A	AH2 with Standard Straight Reducer Outlet
AH2-XX-AB6	AB6	AH2 with Style AB6 Bracket Assembly and V33, V36, or V40 Dry Sprinkler
AH2-CC-XX-AB6	AB6	AH2-CC with Style AB6 Bracket Assembly and V33, V36, or V40 Dry Sprinkler

**NOTE:** Flexible hoses are marked with all UL model designations. In addition, the outlet fitting of the flexible hose is marked with the model's corresponding suffix designation, if applicable. Refer to the chart above to correlate the markings with the UL Listing.

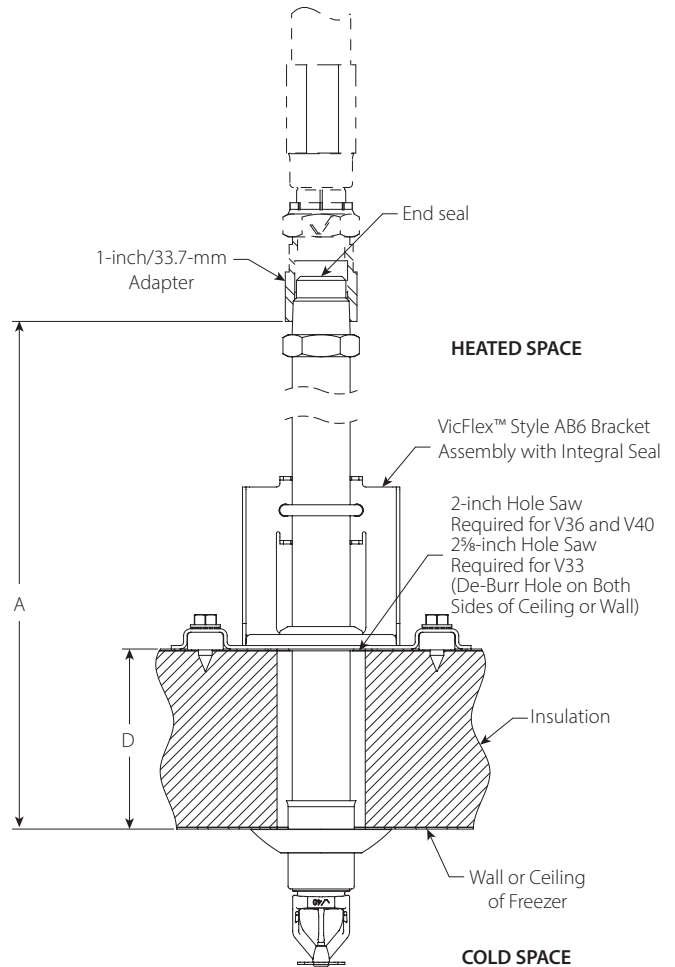

**DRY SPRINKLER INSTALLATION EXAMPLE**  
(Sleeve and Skirt Configuration Shown)

*Exaggerated for Clarity*

## ASSEMBLY WEIGHTS

The values in the table below are the total weight in pounds/kilograms for a Model V33, V36, or V40 Dry Sprinkler, a Series AH2 Flexible Hose (water-filled), and a Style AB6 Bracket Assembly.

V33, V36, or V40 AB6 Order Length inches/mm	Weight – pounds/kilograms									
	AH2-31- AB6		AH2-36-AB6		AH2-48-AB6		AH2-60-AB6		AH2-72-AB6	
	V33/V36	V40	V33/V36	V40	V33/V36	V40	V33/V36	V40	V33/V36	V40
12	6.5	6.1	6.9	6.5	8.1	7.7	9.2	8.8	10.3	9.9
305	3.0	2.8	3.1	3.0	3.7	3.5	4.2	4.0	4.7	4.5
18	7.5	7.0	7.9	7.4	9.1	8.6	10.2	9.7	11.3	10.8
457	3.4	3.2	3.6	3.4	4.1	3.9	4.6	4.4	5.1	4.9
24	8.5	7.9	8.9	8.3	10.1	9.5	11.2	10.6	12.3	11.7
610	3.9	3.6	4.0	3.8	4.6	4.3	5.1	4.8	5.6	5.3
30	9.5	8.8	9.9	9.2	11.1	10.4	12.2	11.5	13.3	12.6
762	4.3	4.0	4.5	4.2	5.0	4.7	5.5	5.2	6.0	5.7

The values in the table below are the total weight in pounds/kilograms for a Model V33, V36, or V40 Dry Sprinkler, a Series AH2-CC Flexible Hose (water-filled), and a Style AB6 Bracket Assembly.

V33, V36, or V40 AB6 Order Length inches/mm	Weight – pounds/kilograms									
	AH2-CC-31-AB6		AH2-CC-36-AB6		AH2-CC-48-AB6		AH2-CC-60-AB6		AH2-CC-72-AB6	
	V33/V36	V40	V33/V36	V40	V33/V36	V40	V33/V36	V40	V33/V36	V40
12	7.5	7.1	7.9	7.5	9.1	8.7	10.2	9.8	11.3	10.9
305	3.4	3.2	3.6	3.4	4.1	4.0	4.6	4.5	5.1	5.0
18	8.5	8.0	8.9	8.4	10.1	9.6	11.2	10.7	12.3	11.8
457	3.9	3.6	4.0	3.8	4.6	4.4	5.1	4.9	5.6	5.4
24	9.5	8.9	9.9	9.3	11.1	10.5	12.2	11.6	13.3	12.7
610	4.3	4.0	4.5	4.2	5.0	4.8	5.5	5.3	6.0	5.8
30	10.5	9.8	10.9	10.2	12.1	11.4	13.2	12.5	14.3	13.6
762	4.8	4.5	5.0	4.6	5.5	5.2	6.0	5.7	6.5	6.2

### ⚠ CAUTION

- It is the system designer's responsibility to verify that the ceiling and/or wall structure can support the weight of the Model V33, V36, or V40 Dry Sprinkler with Integral Style AB6 Bracket Assembly, as detailed in the above table.

Failure to follow this instruction could cause failure of the sprinkler system and sprinkler system components, resulting in property damage.

## NOTES FOR PREPARATION OF SLEEVE AND SKIRT AND RECESSED CONFIGURATIONS

The following section covers steps that are required for preparation of dry sprinklers with removable sleeve and skirt and recessed escutcheon options. **NOTE: RECESSED PENDENT SPRINKLER ASSEMBLIES AND SUPPLIED ESCUTCHEON COMPONENTS ARE NOT FM APPROVED FOR THE 286°F/141°C TEMPERATURE CONFIGURATION.**



- Temporarily remove the bulb protector from the sprinkler. Use caution when removing bulb protector to prevent damage to the bulb, deflector, and frame arms. **DO NOT** use any tools to remove the bulb protector.



- Carefully place sleeve or collar over sprinkler and onto the barrel.

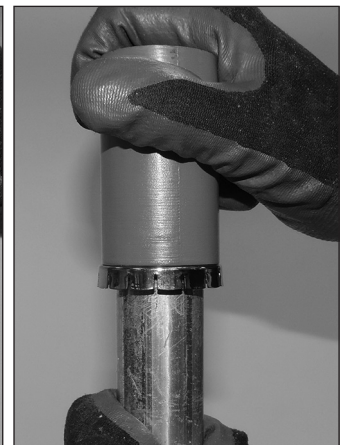

- Using the tool provided, push down on the sleeve or collar just until the sleeve or collar is retained on the barrel. Use caution when using this tool to prevent damage to the bulb, deflector, and frame arms.

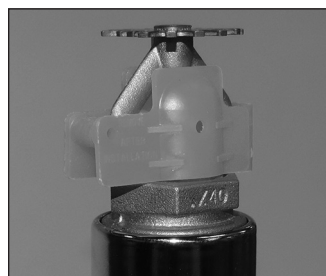

- Reinstall the bulb protector onto the sprinkler. Use caution when reinstalling the bulb protector to prevent damage to the bulb, deflector, and frame arms. **DO NOT** use any tools to reinstall the bulb protector. **Sprinklers showing any signs of damage shall be replaced immediately.**

## INSTALLATION OF THE STYLE AB6 BRACKET ASSEMBLY

### CAUTION

- The hole cut into the ceiling or wall shall be deburred on both sides.

Failure to follow this instruction could cause sprinkler assembly leakage, resulting in property damage.

### NOTICE

- The following photos depict an installation in a freezer application where the Style AB6 Bracket Assembly is installed through the ceiling; however, the installation steps in this section can be applied to any installation orientation.

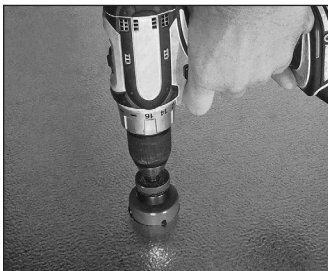

- Drill a hole into the ceiling or wall of the freezer. Use a 2-inch hole saw for V36 and V40 Dry Sprinklers and a 2 3/8-inch hole saw for V33 Dry Sprinklers. **THE HOLE SHALL BE DEBURRED ON BOTH SIDES OF THE CEILING OR WALL.**

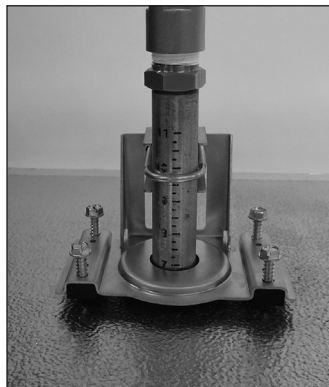

- Insert the V33, V36, or V40 Dry Sprinkler with integral Style AB6 Bracket Assembly into the hole that was drilled in the freezer ceiling or wall.

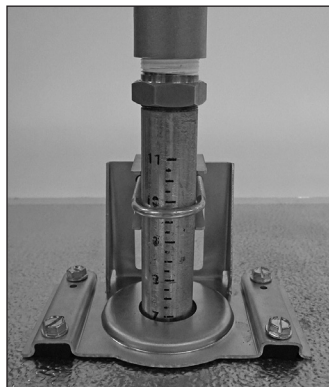
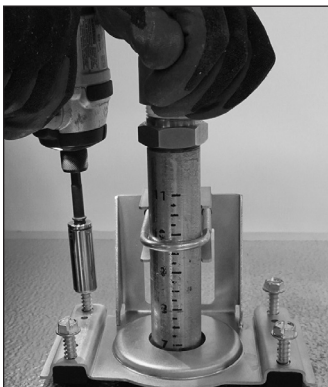

- Tighten each hex flange screw evenly in a crossing pattern until full contact occurs between the mounting bracket and freezer ceiling or wall.

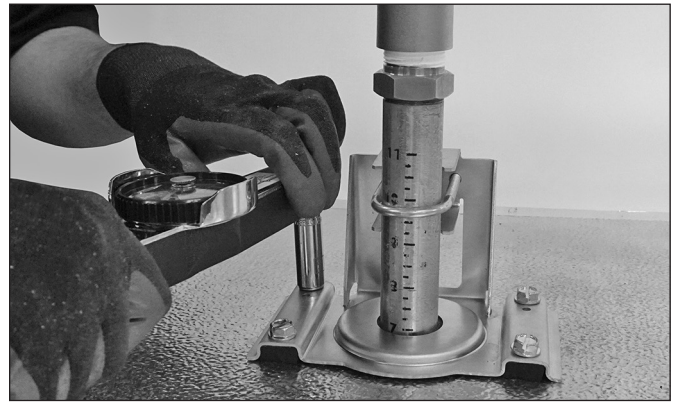

- Tighten each hex flange screw to a torque of 40 inch-lbs/4.5 N•m. DO NOT exceed the specified torque.

## ADJUSTING THE LOCATION OF THE V33, V36, OR V40 DRY SPRINKLER



- Support the barrel of the V33, V36, or V40 Dry Sprinkler while loosening the two nuts located at the back of the Style AB6 Bracket Assembly.



- Slide the barrel of the V33, V36, or V40 Dry Sprinkler up or down to the desired location.

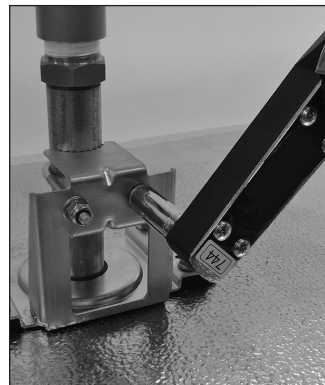

- Retighten each nut located at the back of the Style AB6 Bracket Assembly to a torque of 45 inch-lbs/5.1 N•m. DO NOT exceed the specified torque.

## 1-INCH/DN25 IGS CONNECTION TO THE SPRINKLER PIPING USING A SERIES AH2-CC FLEXIBLE HOSE

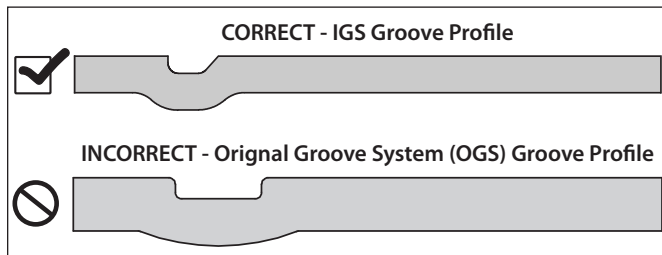

Pipe and grooves are not shown to scale

The Style 108 Coupling of the Series AH2-CC shall be used **ONLY** with sprinkler piping connections that are prepared to Victaulic IGS proprietary groove specifications. **DO NOT** attempt to install the coupling on sprinkler piping connections that are prepared to any other groove specification. Refer to Victaulic publication 25.14 for the IGS groove specification, which can be downloaded at victaulic.com.

**WARNING**

- The flexible hose shall not be bent or fluctuated up-and-down or side-to-side when pressurized.

Failure to follow this instruction could cause improper sprinkler operation, resulting in death or serious personal injury and property damage.

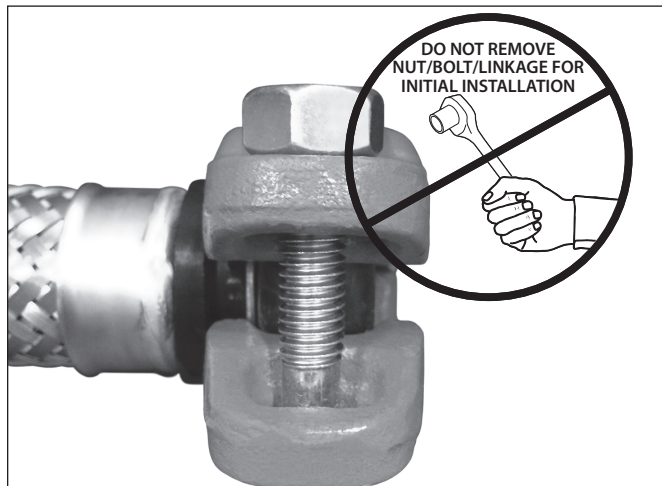

- DO NOT DISASSEMBLE THE COUPLING:** The Style 108 Coupling of the Series AH2-CC is designed so that the installer does not need to remove the nut, bolt, or linkage for initial installation. This facilitates installation by allowing the installer to directly insert the sprinkler piping's grooved end into the coupling.
- The outside surface of the sprinkler piping, between the groove and the end of the sprinkler piping, shall be generally free from indentations, projections, weld seam anomalies, and roll marks to ensure a leak-tight seal. All oil, grease, loose paint, dirt, and cutting particles shall be removed.

The sprinkler piping's outside diameter ("OD"), groove dimensions, and maximum allowable flare diameter shall be within the tolerances published in current Victaulic IGS specifications, publication 25.14, which can be downloaded at victaulic.com.

- Check the gasket to verify that it is suitable for the intended service. The color code identifies the material grade. **Refer to Victaulic publication 05.01 for the color code chart, which can be downloaded at victaulic.com, and the "NOTICE" below for important gasket information.**

**CAUTION**

- If any conditions listed in the "NOTICE" below are met, a thin coat of a compatible lubricant shall be applied only to the gasket sealing lips to help prevent pinching, rolling, or tearing during installation.
- DO NOT** use excessive lubricant on the gasket sealing lips.

Failure to use a compatible lubricant may cause gasket damage, resulting in joint leakage and property damage.

- If any conditions listed in the "NOTICE" below are met, apply a thin coat of a compatible lubricant, such as Victaulic Lubricant or an EPDM-compatible lubricant, only to the gasket sealing lips. Silicone grease may be used (silicone spray is not a compatible lubricant).

**NOTICE**

- Gaskets for Style 108 Coupling assemblies of Series AH2-CC Flexible Hoses are pre-lubricated. Additional lubrication is not required for the initial installation of wet pipe systems that are installed at or continuously operating above 0°F–18°C.

Supplemental lubrication is required only if any of the following conditions exist. Apply a thin coat of a compatible lubricant to the gasket sealing lips, as noted in step 3a on this page. It is not necessary to remove the gasket from the housings to apply additional lubricant to the gasket sealing lips.

- If the installation or continuous operating temperature is below 0°F–18°C
- If the gasket has been exposed to fluids prior to installation
- If the surface of the gasket has a dark black or shiny appearance
- If the gasket is being installed into a dry pipe system
- If the system will be subjected to air tests prior to being filled with water
- If the gasket was involved in a previous installation

Lubricated gaskets will not enhance sealing capabilities on adverse sprinkler piping conditions. Sprinkler piping condition and preparation shall conform to the requirements listed in these product installation instructions.

**WARNING**

- Never** leave a Style 108 Coupling of a Series AH2-CC partially assembled on grooved sprinkler piping. **ALWAYS TIGHTEN THE HARDWARE IMMEDIATELY IN ACCORDANCE WITH THESE INSTRUCTIONS.** A partially assembled coupling poses a drop or fall hazard during installation and a burst hazard during testing.
- Keep hands away from the grooved sprinkler piping and the openings of the coupling when attempting to insert the grooved sprinkler piping into the coupling.
- Keep hands away from coupling openings during tightening.

Failure to follow these instructions could result in death or serious personal injury and property damage.

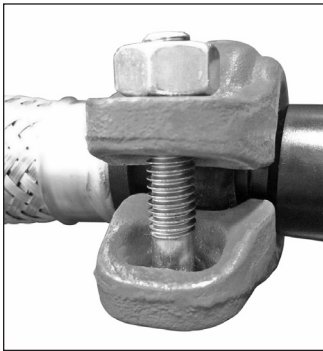

4. Assemble the joint by inserting the grooved end of the sprinkler piping into the opening of the coupling. The grooved sprinkler piping shall be inserted into the coupling until contact with the center leg of the gasket occurs. A visual check is required to verify that the coupling keys align with the groove in the sprinkler piping and engage with the spacer on the inlet end of the flexible hose.

**WARNING**

- The nut shall be tightened until metal-to-metal contact occurs at the bolt pads, as indicated in steps 5 and 6.
- DO NOT overtighten coupling hardware.

Failure to follow instructions for tightening hardware could result in:

- Personal injury or death
- Bolt damage or fracture
- Damaged or broken bolt pads or coupling fractures
- Joint leakage and property damage
- A negative impact on system integrity

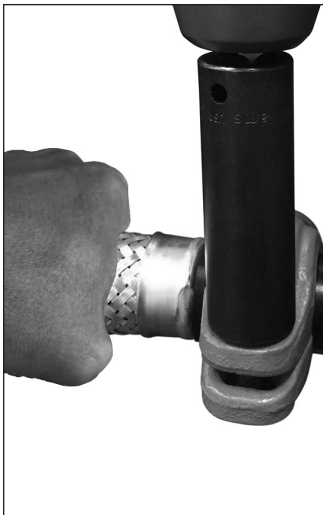

Oval Neck of Bolt Seated Properly



Oval Neck of Bolt Not Seated Properly

5. Using an impact tool or a standard socket wrench with an 1/16-inch (for Imperial nut)/17-mm (for Metric nut) deep well socket, tighten the nut until metal-to-metal contact occurs at the bolt pads. Verify that the oval neck of the bolt seats properly in the bolt hole. DO NOT continue to tighten the nut after metal-to-metal bolt pad contact is achieved. **If you suspect that any hardware has been over-tightened (as indicated by a bend in the bolt, bulging of the nut at the bolt pad interface, or damage to the bolt pad, etc.), the entire coupling assembly shall be replaced immediately.** **NOTE:** During tightening, support the hose near the Style 108 Coupling to verify that the inlet end of the Series AH2-CC Flexible Hose remains straight and aligned with the coupling.

**WARNING**

- Visual inspection of each joint is required.
- Improperly assembled joints shall be corrected before the system is tested or placed into service.
- Any components that exhibit physical damage due to improper assembly shall be replaced before the system is tested or placed into service.

Failure to follow these instructions could cause joint failure, resulting in death or serious personal injury and property damage.

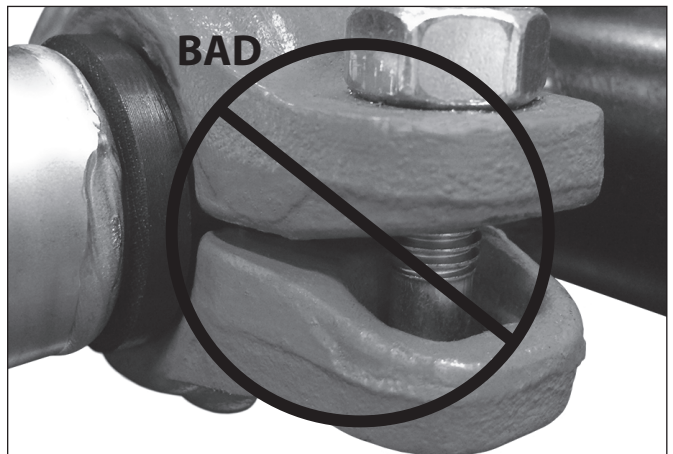
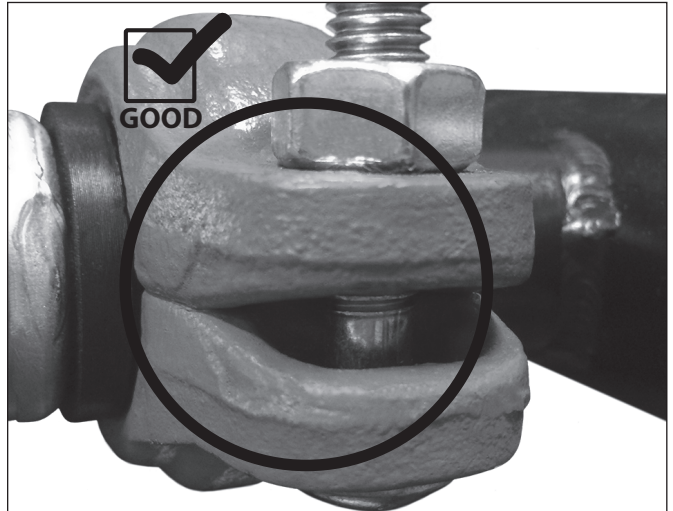

6. Visually inspect the bolt pads at each joint to verify that metal-to-metal contact is achieved, in accordance with step 5.

**NOTICE**

- Refer to the instructions on page 10 for reassembly requirements.

**INSTRUCTIONS FOR INITIAL USE OF A VICTAULIC® FIRELOCK™ NO. 101 90° ELBOW OR NO. 102 STRAIGHT TEE INSTALLATION-READY™ FITTING WITH A SERIES AH2-CC FLEXIBLE HOSE (1-INCH/DN25 IGS CONNECTION)**

**NOTICE**

- The following procedure applies only to 1-inch/DN25 No. 101 90° Elbows and No. 102 Straight Tees (IGS connection).
- No. 101 90° Elbows and No. 102 Straight Tees do not ship preassembled to the Series AH2-CC Flexible Hose.
- The No. 101 or No. 102 does not need to be fully disassembled for initial installation onto the inlet end of the Series AH2-CC Flexible Hose.

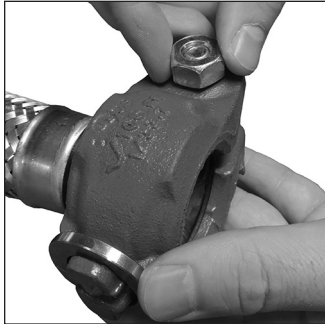

1. Loosen the nut of the Style 108 Coupling. Remove the Style 108 Coupling from the end of the Series AH2-CC Flexible Hose.

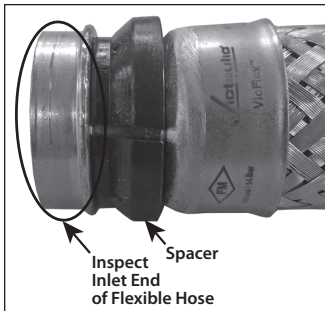

2. Inspect the inlet end of the Series AH2-CC Flexible Hose to verify that there is no damage (dents, crushed edges, etc.). A new, Victaulic-supplied Series AH2-CC Flexible Hose shall be used if any damage is present.
3. Verify that the spacer is oriented on the inlet end of the Series AH2-CC Flexible Hose, as shown to the left.

4. Loosen and remove the hardware from the side of the No. 101 90° Elbow or No. 102 Straight Tee that is intended to connect with the inlet of the Series AH2-CC Flexible Hose.

**No. 101**

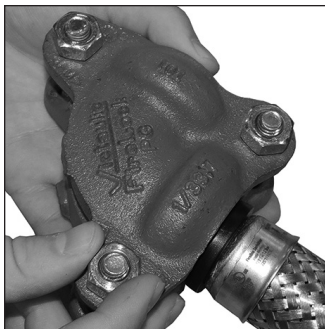

**No. 102**

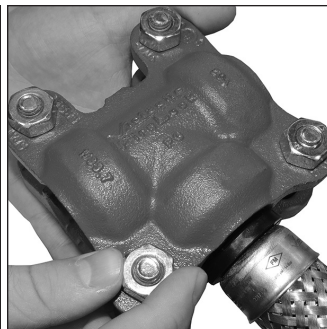

5. Insert the inlet end of the Series AH2-CC Flexible Hose into the No. 101 90° Elbow or No. 102 Straight Tee. Verify that the gasket is seated fully in the gasket pocket of each housing and that the housings' keys engage with the spacer on the inlet end of the Series AH2-CC Flexible Hose.
- 5a. Reinstall the two bolts and nuts that were removed in step 4. **NOTE:** Verify that the oval neck of each bolt seats properly in the bolt holes. DO NOT tighten the nuts completely. The bolt pads need to be set at a gap for installation of the fitting. The nuts should be flush with the top of each bolt to provide the proper gap. Use caution when handling the fitting/hose assembly (the fitting may not be secured completely to the inlet end of the Series AH2-CC Flexible Hose).

6. Follow the steps in the I-101/103 or I-102/104 installation instructions for the required tightening sequence. **NOTE:** During tightening, verify that the inlet end of the Series AH2-CC Flexible Hose remains straight and aligned with the opening of the No. 101 90° Elbow or No. 102 Straight Tee. The I-101/103 or I-102/104 can be accessed and downloaded by scanning the applicable QR code below. In addition, these instructions contain important reassembly instructions and shall be referenced any time a No. 101 90° Elbow or No. 102 Straight Tee is removed from the sprinkler piping and reused.



Scan QR Code for Access to the Full I-101/103 Installation Instructions ON VICTAULIC.COM



Scan QR Code for Access to the Full I-102/104 Installation Instructions ON VICTAULIC.COM



## CONNECTION TO THE BRANCH LINE USING AN ADAPTER NIPPLE AND A SERIES AH2 FLEXIBLE HOSE

### WARNING

- The flexible hose shall not be bent or fluctuated up-and-down or side-to-side when pressurized.

Failure to follow this instruction could cause improper sprinkler operation, resulting in death or serious personal injury and property damage.

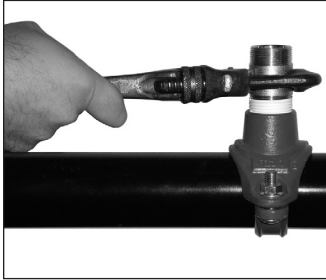

- Apply pipe joint compound or PTFE thread sealant tape to the tapered threads of the adapter nipple, in accordance with the pipe joint compound or tape manufacturer's instructions. Using a pipe wrench, tighten the adapter nipple into the sprinkler piping.

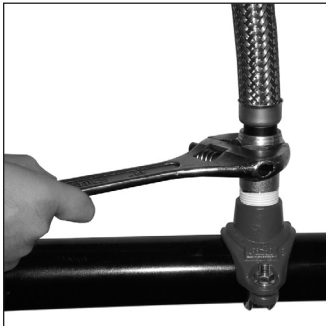

- Confirm that the seal inside the nut of the flexible hose is in place and is free from damage prior to installation. Connect the nut to the adapter nipple, as shown to the left.

- DO NOT use pipe joint compound or PTFE thread sealant tape on the threads of the adapter nipple. The seal inside the nut of the flexible hose provides the leak-proof connection.
- Tighten the connection nut to a torque of 40ft-lbs/54 N•m (approximately ½ to ¾ of a turn past hand-tight). **NOTE:** To prevent damage to the seal, tighten the assembly by applying torque only to the connection nut and DO NOT exceed the specified torque.

## INSTALLATION OF THE SERIES AH2 OR AH2-CC FLEXIBLE HOSE TO THE STYLE AB6 THREADED INLET ADAPTER

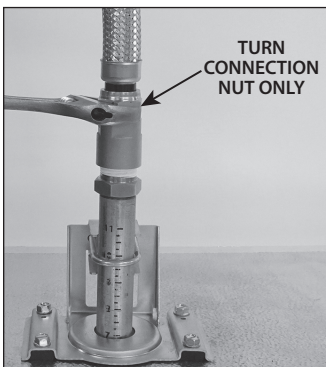

- Confirm that the seal inside the nut of the Series AH2 or AH2-CC Flexible Hose is in place and is free from damage prior to installation. Connect the nut to the threaded inlet adapter of the Style AB6 Bracket Assembly, as shown to the left.

- DO NOT use pipe joint compound or PTFE thread sealant tape on the threads of the inlet to the Style AB6 Bracket Assembly. The seal inside the nut of the flexible hose provides the leak-proof connection.
- Tighten the connection nut to a torque of 40ft-lbs/54 N•m (approximately ½ to ¾ of a turn past hand-tight). **NOTE:** To prevent damage to the seal, tighten the assembly by applying torque only to the connection nut and DO NOT exceed the specified torque.

## INSTALLATION OF THE SKIRT, RECESSED ESCUTCHEON, OR FLUSH PLATE

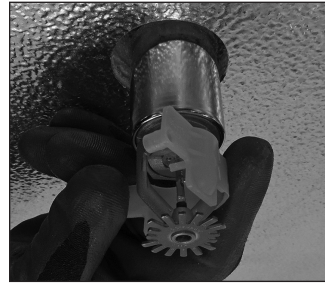

- Temporarily remove the bulb protector from the sprinkler. Use caution when removing to bulb protector to prevent damage to the bulb, deflector, and frame arms. DO NOT use any tools to remove the bulb protector.

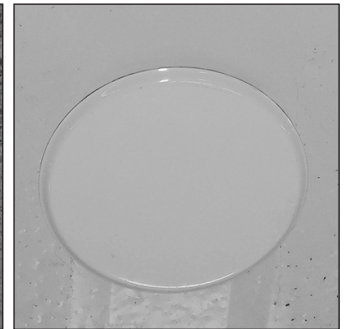
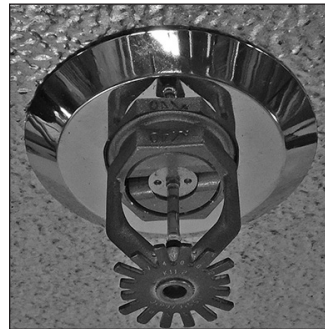

- Install the skirt, recessed escutcheon, flush plate, or concealed cover plate, as shown above. Verify that the skirt, recessed escutcheon, flush plate, or concealed cover plate is in full contact with the freezer ceiling or wall.



- Reinstall the bulb protector onto the sprinkler until the sprinkler system is placed in service. Use caution when reinstalling the bulb protector to prevent damage to the bulb, deflector, and frame arms. DO NOT use any tools to reinstall the bulb protector.

## BULB PROTECTOR REMOVAL

### WARNING

- Sprinklers cannot operate properly with bulb protectors in place.
- Bulb protectors shall be removed from all sprinklers before the sprinkler system is placed in service.
- DO NOT use any tools to remove bulb protectors.

Failure to follow these instructions will cause improper sprinkler operation, resulting in death, serious personal injury, or property damage.

- Remove the bulb protector from all sprinklers carefully by hand before the sprinkler system is placed in service.

## INSTRUCTIONS FOR REASSEMBLY OF A SERIES AH2-CC FLEXIBLE HOSE

### **WARNING**

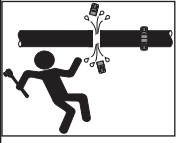

- Always verify that the piping system has been completely depressurized and drained immediately prior to installation, removal, adjustment, or maintenance of any Victaulic products.

- Confirm that any equipment, branch lines, or sections of piping that may have been isolated for/during testing or due to valve closures/positioning are identified, depressurized, and drained immediately prior to installation, removal, adjustment, or maintenance of any Victaulic products.

Failure to follow this instruction could result in death or serious personal injury and property damage.

1. Verify that the system is depressurized and drained completely before attempting to remove a Series AH2-CC Flexible Hose from the sprinkler piping.
2. While supporting the Style 108 Coupling, loosen the nut until backed off no further than flush with the end of the bolt. Carefully remove the flexible hose/coupling assembly from the sprinkler piping.
3. Fully disassemble the Style 108 Coupling from the inlet end of the Series AH2-CC Flexible Hose by removing the nut, bolt, gasket, and linkage from the housings. Inspect all components for any damage or wear. If any damage or wear is present, use a new Victaulic-supplied coupling assembly.
4. Verify that the outside surface of the sprinkler piping, between the groove and the end of the sprinkler piping, is generally free from indentations, projections, weld seam anomalies, and roll marks to ensure a leak-tight seal. All oil, grease, loose paint, dirt, and cutting particles shall be removed.

The sprinkler piping's outside diameter ("OD"), groove dimensions, and maximum allowable flare diameter shall be within the tolerances published in current Victaulic IGS specifications, publication 25.14, which can be downloaded at [victaulic.com](http://victaulic.com).

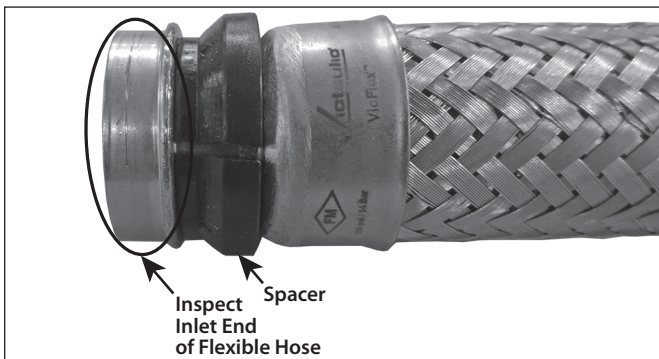

5. Inspect the end of the Series AH2-CC Flexible Hose to verify that there is no damage (dents, crushed edges, etc.). A new, Victaulic-supplied Series AH2-CC Flexible Hose shall be used if any damage is present.
6. Verify that the spacer is oriented on the inlet end of the Series AH2-CC Flexible Hose, as shown above.

### **CAUTION**

- A thin coat of a compatible lubricant shall be used to help prevent the gasket from pinching, rolling, or tearing during reassembly.
- DO NOT use excessive lubricant on the gasket sealing lips and exterior.

Failure to use a compatible lubricant may cause gasket damage, resulting in joint leakage and property damage.



7. Apply a thin coat of a compatible lubricant, such as Victaulic Lubricant or an EPDM-compatible lubricant, to the gasket sealing lips and exterior. Silicone grease may be used (silicone spray is not a compatible lubricant). It is normal for the gasket to have a hazy white appearance after it has been in service.



8. Place the lubricated gasket onto the inlet end of the flexible hose, then place the Style 108 Coupling housings over the gasket. Verify that the gasket is seated fully in the gasket pocket of each housing and that the housings' keys engage with the spacer.



9. Install the linkage onto the housings, as shown to the left.



10. Install the bolt, and thread a nut onto the bolt.  
**NOTE:** Verify that the oval neck of the bolt seats properly in the bolt hole. DO NOT tighten the nut completely. The bolt pads need to be set at a gap for reinstallation of the coupling. The nut should be flush with the top of the bolt to provide the proper gap.

11. Follow all steps on page 7.

# TECHNICAL DATA FOR FLEXIBLE HOSES

**The following section provides friction loss information for flexible hoses that can be used with Style AB6 Bracket Assemblies.**

**⚠ WARNING**

- It is the system designer's responsibility to verify suitability of stainless steel flexible hose for use with the intended fluid media within the piping system and external environment.
- The material specifier shall evaluate the effect of chemical composition, pH level, operating temperature, chloride level, oxygen level, and flow rate on stainless steel components to confirm system life will be acceptable for the intended service.

Failure to follow these instructions could cause product failure, resulting in death or serious personal injury and property damage.

**SERIES AH2 AND AH2-CC FLEXIBLE HOSE FRICTION LOSS DATA (FM AND UL)**

Model	Length of Flexible Hose inches/mm	Sprinkler K-Factor	Equivalent Length of 1-inch/DN25 Schedule 40 Pipe feet/meters		Maximum Number of 90° Bends§	
			FM*	UL‡	FM	UL
AH2-31 AH2-CC-31	31 790	5.6	13.8	26.0 7.9	2	4
		8.1	4.2			
		8.0	20.7			
		11.5	6.3			
		11.2	–			
16.1	–					
AH2-36 AH2-CC-36	36 915	5.6	16.6	28.0 8.5	2	5
		8.1	5.1			
		8.0	25.0			
		11.5	7.6			
		11.2	–			
16.1	–					
AH2-48 AH2-CC-48	48 1220	5.6	23.4	37.0 11.3	3	8
		8.1	7.1			
		8.0	35.5			
		11.5	10.8			
		11.2	–			
16.1	–					
AH2-60 AH2-CC-60	60 1525	5.6	30.2	50.0 15.2	4	10
		8.1	9.2			
		8.0	39.6			
		11.5	12.1			
		11.2	–			
16.1	–					
AH2-72 AH2-CC-72	72 1830	5.6	37.0	59.0 18.0	4	12
		8.1	11.3			
		8.0	43.5			
		11.5	13.3			
		11.2	–			
16.1	–					

\* 7-inch/178-mm minimum bend radius

‡ 2-inch/50-mm minimum bend radius

§ A higher number of bends may be permitted, provided the sum of degrees is equal to or less than the total maximum allowable degrees of bends (e.g. Two 90° bends equal 180°. Three 90° bends equal 270°). The minimum bend radius and maximum number of 90° offset (bends), stated in these installation instructions, refer to the final installed condition of the hose.

NOTE: Differences in equivalent lengths are due to varying test methods, per UL 2443 and FM 1637 standards. Refer to these standards for additional information regarding friction loss test methods.

When using a No. 101 90° Elbow or a No. 102 Straight Tee in place of a Style 108 Coupling on the end of a Series AH2-CC Flexible Hose, the friction loss data shown above shall be added to the No. 101 or No. 102 friction loss data published in Victaulic publication 10.54.

---

**Victaulic® VicFlex™ Sprinkler Fittings: Style AB6 Bracket Assembly  
with Models V33, V36, or V40 Dry Sprinklers**

---

---

For complete contact information, visit [victaulic.com](http://victaulic.com)

**I-VICFLEX.AB6 7084 REV H UPDATED 09/2020 Z000AB6000**

VICTAULIC AND VICFLEX ARE TRADEMARKS OR REGISTERED TRADEMARKS OF VICTAULIC COMPANY AND/OR ITS AFFILIATED ENTITIES  
IN THE UNITED STATES AND/OR OTHER COUNTRIES. © 2020 VICTAULIC COMPANY. ALL RIGHTS RESERVED.

