

Planning, Installation and Maintenance Instructions for Rubber Compensators with Rotary Flanges and Solid Flanges

WILLRANDT Rubber Compensators will be supplied ready for installation in two designs. Once with one-piece swivel steel retaining flanges, in accordance with the standard interface (DIN, ASA, BS etc.)

These flanges should fit neatly, without any burr within the clamping range of the rubber bellow with a rubber sealing surface protruding about 1 -10 mm, depending on the nominal width. The counterflange sealing surfaces may be designed smooth or rather with sealing face, according to EN 1092 - 1:2001 (form A or B).

The second group will be supplied with pressure-strengthened solid rubber flanges including one-piece steel retaining flanges in accordance with the standard connection (DIN, ASA, BS, etc.). The counter flanges should be designed with smooth sealing surface.

Both compensators are self-sealing, additional gaskets are not required.

1. Planning instructions

The lines must be designed in such a manner that the compensators are guided by fixed bearings (FP) or sliding bearings (GL); see:

Installation example 1

Compensating of axial expansion with unbraced compensators.

Installation example 2

Compensating lateral and axial expansion with an unbraced compensator.

Installation example 3

Compensating of lateral and axial expansion with unbraced compensators at an outgoing pipe.

Installation example 4

Compensating of axial expansion by angular movement reversal with braced compensators. Advantage: Large axial expansions can only be absorbed by two compensators.

Installation example 5

Arrangement of pipe hinge compensators in three hinge systems for absorbing expansion in two directions. Advantage: High expansion absorbing rates, low adjusting forces, a soft corner.

Installation example 6

Use of rubber compensators with pumps. In this case compensators in the pressure line should always be braced to ensure that internal pressure does not overload the pump connecting piece. A vacuum bearing ring should be used on the suction side if the negative pressure exceeds 0.8 bar, absolute.

2. Bracing examples

Rubber compensators in order to take up axial must be installed between fixed points expansion. The axial and lateral expansion must be transformed where this is not possible so that braced rubber compensators can be used to neutralize the arising reaction forces (inside surface of the compensator multiplied by the operating pressure). In this arrangement only appropriate sliding bearings can be used for correct introduction of the expansion.

An extensive range of rubber compensator bracings is listed in our catalogue.

3. IMPORTANT

When conveying abrasive media (liquids containing solids, e.g. water/sand) the compensators must not be directly attached to the pump connecting piece (suction/pressure side), due to a risk of the compensators being damaged by the relatively high speeds associated with the twist and whirl formations in the pump connecting piece. This also applies to bent pipes and tailings.

EB 7

The installation space between the pump connecting piece and compensator must be 1 to 1.5 times the nominal diameter (DN). Pump operation against a totally or partially closed gate or flap valve must be avoided. Cavitation must also be avoided as this can result in the rapid destruction of the compensator.

EB 8 (Axial prestress)

With axial prestress it is necessary to ensure that the compensators are prestressed by not more than maximum 10 mm when in a non-installed state. For higher prestresses a compensator in conformity with **EB 8** must be used, i.e. the compensator must be first fully installed after which the corresponding prestress is generated with the firmly installed compensator.

Reason: With a higher prestress in a non-installed state, the sealing bead can spring out of the holder of the steel backing flange and damage the sealing bead in the process.

EB 8 (Lateral prestress)

For compensator arrangement, it must be ensured when dimensioning the pipe that any necessary lateral prestress must be applied only with a securely installed compensator by means of pipe misalignment (**EB 8a**). A lateral prestress of only 5mm is possible prior to installation. It must however be ensured that the rubber bead is not pulled out of the groove in the steel backing flange.

EB 9

Regarding rubber bonded pipes or fittings rubber bonded with a rubber to rubber gasket is to avoid by using isolation disk.

4. Safety measures

The pipes must be protected against impermissible overpressure, excessive rise of temperature and uncontrolled vacuum. The limiting values for the respective settings are shown in the data sheets of our catalogue relating to the respective types. In addition, appropriate drain and venting options should be provided to prevent water impact and vacuum failures, which can also cause compensator damage.

Medium safety

Since the inside of the compensator comes into contact with the media, it must be ensured that only media is pumped as specified in the resistance list as suitable for the inner rubber.

If other media are used we should be notified of the same together with the relevant data in accordance with the safety data sheet for chemical substances and preparation as per DIN 52900, Item 1 to 2.13, in order that we may ascertain whether the inner rubber of the compensator is suitable.

Flow rates

With high flow rates it is necessary to clarify whether the compensators have to be installed with or without a guiding pipe to avoid wear as a result of excessive whirling.

Mating flanges

Mating flanges must conform in their design with **EB 10** to ensure reliable sealing and clamping of the rubber compensators.

Counter flanges with or without protrusion may be used for compensators with swivel flanges in accordance with EN EN 1092-1:2001 form A or B. There should only be used smooth counter flanges for compensators with solid flanges.

Vacuum supporting ring (EB15)

With application of vacuum supporting rings it must be observed that the vacuum supporting rings will be checked up on right positioning after assembly when application is directly behind the pump, damper or pipe elbow.

- a. exact fit (max. 10 - 15 mm play between bellow and ring onesided).
- b. Where necessary insertion of adapter plates to achieve the acceptable play of seating.
- c. The connection lock should always lay in the lower flow range (6°).
- d. With high velocity flow it should always be checked whether a compensator with vulcanized supporting ring should be applied to avoid possible vibration crackings by strong turbulent flows.
- e. After assembly please check whether the hexagon socket wrench and the hexagon nuts are secured accordingly against loosening.

5. Transport

Packaging Package parts.

Note „TOP" at the top and „cable or lifting hook" steel backing rings (with bracing) and the rubber compensator flanges must remain fastened until final mounting. The relatively light rubber part is bonded to heavy metal flanges - avoid excessive loading of the rubber part.

Tools

No sharp-edged tools, wire cables, chains or lifting hooks (danger of damage to rubber).

Lifting and moving

Always lift both steel flanges simultaneously. Shackle at both sides or place padded tie-bars through the compensator or lift both sides.

Ground level transportation

Move flanges by rolling.

6. Installation

- 6.1 Check the packaging of the rubber compensators for damage. Damaged compensators must never be released for installation.
- 6.2 Check the envisaged installation gap. The mating flange must be installed in true alignment. The maximum deviation within the installation gap in relation to the compensator is +10 mm, minus the corresponding expansion specifications. The maximum lateral deviation of the flange is 5 mm.
- Note:** If it is not possible to observe the above tolerances then proceed with an axial/lateral prestress as defined by **EB 8 / EB 8a**.
- 6.3 Do not use sharp-edged tools. Additional gaskets are not required. The compensator rubber flange seals directly on to the pipe flange.
- 6.4 Fasten the compensator at both flanges with e.g. 2 threaded rods before loosening the lifting device.
- 6.5 **Arrangement of the screws EB 10**
For compensators that have through-holes the screw heads must face the bellow to avoid damaging the bellow body when under pressure. For compensators with threaded holes in the flange, the screws must fit flush with the inner side of the flange in relation to the bellow so that protruding screws cannot damage the bellow when under pressure.

- 6.6 The flange screws must be evenly tightened in alternation as shown in Table 1 and 2 (page 69/70). It must also be ensured that the sealing bead does not tilt. The entire protruding sealing surface must be uniformly compressed. The screws must be evenly tightened crosswise 3-4 times.
- 6.7 **Tightening with a torque wrench**
Evenly tighten all screws manually (step 1) (ensure parallelism with the sealing surfaces). Then step 2 and 3 crosswise (acc. to table 1 and 2 page 69/70). After the third stage, 30 minutes should be allowed to pass before retightening to the final torque specified in step 3. Further tightening of the screws is unnecessary, particularly since this could destroy the surface seal.
- 6.8 Do not use plain washers on steel backing flanges.
- 6.9 Do not weld close to the rubber compensator. If necessary, cover the compensator with asbestos for protection against welding heat and flying sparks (sparks and temperatures above 80°C will damage the rubber parts!).
- 6.10 **Attention:**
When welding, steel-wire compensators throughout the whole piping system can be damaged by current leakage or electrical earthing. The anode and cathode of the E welding connection must always be on the same section of piping. (Not separated by the rubber compensator!).
- 6.11 **Attention: Bellow**
Bellow must not be painted or insulated by a temperature above 50°C. Heating and hardening of the rubber.

7. Pipe leading

Anchor points and mountings

Prior to filling the piping, it must be ensured that all anchor points and mountings are installed and operational. The bracing anchors must provide uniform support and must be adjusted to the existing piping.

8. Final installation inspection

8.1 Damage

Check complete compensators for visible damage and in particular clean the gap between the steel backing flange and rubber bellow (remove foreign bodies, sand, etc.).

8.2 After the compensators have been installed they should be protected in an appropriate manner against damage, and the protection should only be removed just before putting into operation.

8.3 The rubber parts must not be over-painted. Solvents and chemicals will attack the surface and destroy the bellow.

8.4 The compensators must not be insulated as this can result in overheating and drying the bellow and damage to the same.

8.5 The best operating results are achieved when the compensator operates stress-free under operating conditions (take appropriate prestressing into account during installation).

8.6 The fixed points must be checked to see whether they are suitable for absorbing the reaction force from the non-braced compensator or whether the adjusting forces and initiation of expansion with appropriate sliding bearings take place at the correct distance from the compensator.

8.7 Compensators braced with tie rods should be appropriately adjusted following installation. The tie rods should be able to be turned hand-tight. All hexagon nuts must subsequently be locked with lock nuts.

8.8 After mounting check the supporting rings on the right seat and fuse.

8.9 Leakages

Tighten bolts when possible leakages occur during pressure testing (1.3 x design pressure).

9. Pressure test

The rubber compensator is not a proper pressure vessel, but is classified according to the Pressure Equipment Directive as a "pipe accessory" (pipe component). When including the compensator in the pipeline, sealing does not take place via a separate seal, but directly on the integrated surface seal of the rubber bellow.

A one hundred per cent pressure test of the rubber compensators at the manufacturer can adversely influence the integrated rubber sealing surface. For this reason, pressure testing of the rubber compensators at the manufacturer takes place only at the special request of the customer with the utmost care.

The pressure test is normally carried out only after the rubber compensators have been fully installed in the pipeline system. The information contained in these installation instructions should be observed prior to the pressure test.

10. Storage

See DIN 7716 - guidelines for the storage of rubber parts: Rubber compensators must be stored free of stress, deformation and bending. Rubber compensators with steel flanges must be stored upright on the flanges (to avoid the risk of crushing).

Storage room

The storage room must be cool, dry, dust-free and moderately ventilated.

Oxygen and ozone

Rubber parts must be protected from draughts. If necessary they should be covered. Do not operate any ozone-generating facilities in the storage room, e.g. electric motors, fluorescent lamps, etc.

Other jointly stored media

Do not store solvents, fuels, chemicals or similar substances in the same storage room.

11. Supplementary installation and mounting instructions for type 45 - 46 (EB 11)

The type 46 rubber compensator should be installed free of any tension. Screws should always be tightened with two wrenches to avoid damaging torsions being transmitted to the compensator; see **EB 11**.

Installation procedure

1. Attach the screw-joining parts to the pipe and check the installation gap! The installation gap must equal the compensator length (130 mm +5 mm).
2. Insert the compensator and tighten with two wrenches.

Nominal diameters DN 20 - 25

The front screw-in part is used as a steady while the union nut is tightened (to avoid the transmission of torsions to the bellow).

Nominal diameters DN 32 - 50

The rear screw-in part is used as a steady while the union nut is tightened (to avoid the transmission of torsion to the bellow).

See main installation instructions for all other installation points.

Tightening torque for all types 100 Nm.

12. Additional installation and assembly instructions for pressure balanced compensators

Compensators for receiving axial extension without reaction forces are transferred from high or low pressure on the adjacent bearing, equipment or machinery (**EB 12**).

Compensators to accommodate axial- and lateral extension in a pipe elbow without that the reaction forces are transferred from positive and negative pressure on the adjacent bearing (**EB 13**).

13. Additional installation and assembly instructions for compensators as dismantling device

In order to balance imprecise assembly on valves or for simple installation and removal tight joints may be used. On the one hand the tensions prevent the transfer of reaction forces on the connected valve. On the other hand after loosening the flange connection by means of the restraint flange the rubber bellow can be compressed by its maximum possible axial movement in order to create space for dismantling the valve (**EB 14**).

14. Maintenance and Monitoring

- 14.1 Before final commissioning, check the tightening torque of the flanged joints.
- 14.2 Rubber parts must not be painted and should be kept clean. (Clean with water or soapy water). Keep the parts free from grease and oil.
- 14.3 Rubber parts should not be insulated when the temperature exceeds 50°C. (Heating and hardening of the rubber.)
- 14.4 Inspection must be carried out minimum one week after commissioning. Tighten flange bolts with torque wrench. Inspections must be carried after 1,4 and 12 months, then annually.
- 14.5 Inspection criteria
 - External damage to rubber and bracing.
 - Deformation of rubber flange external diameter between the bolts (flange surface displacement).
 - Variations in the rubber bellow (blister formation, brittleness, fissures, hairline cracks)
 - Check bracing for excessive movement and misalignment.

Assess corrosion and wear over the whole component.

Installation Examples

EB 1

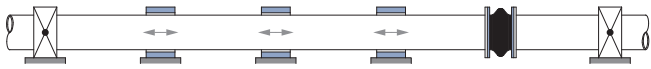

EB 2

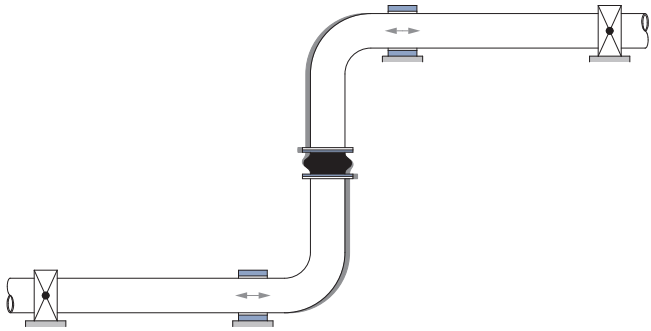

EB 3

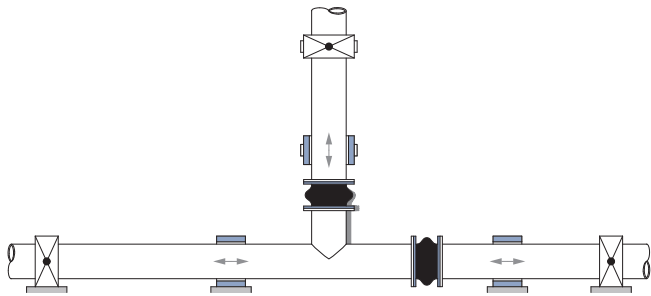

EB 4

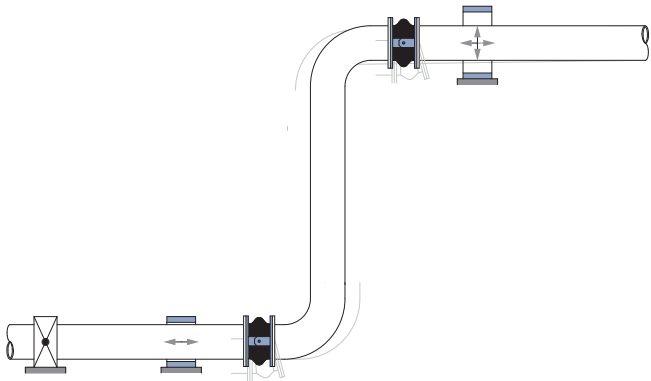

EB 5

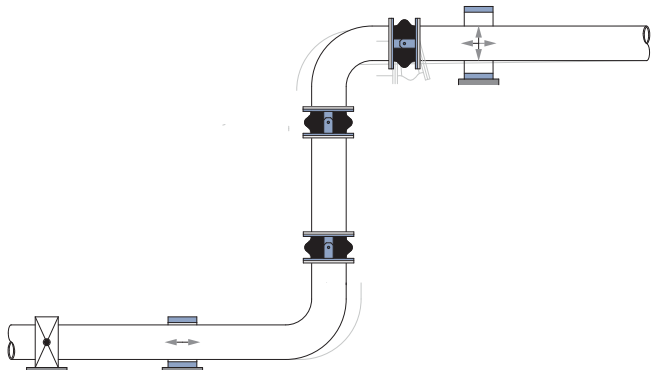

EB 6

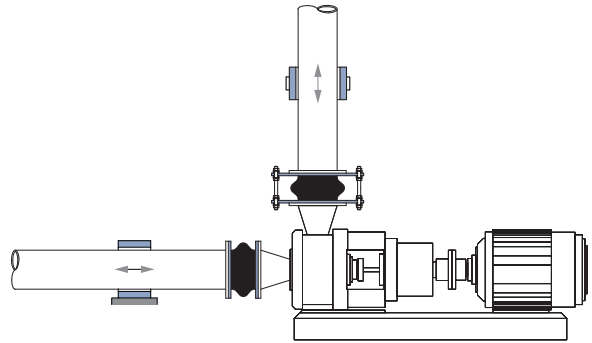

EB 7

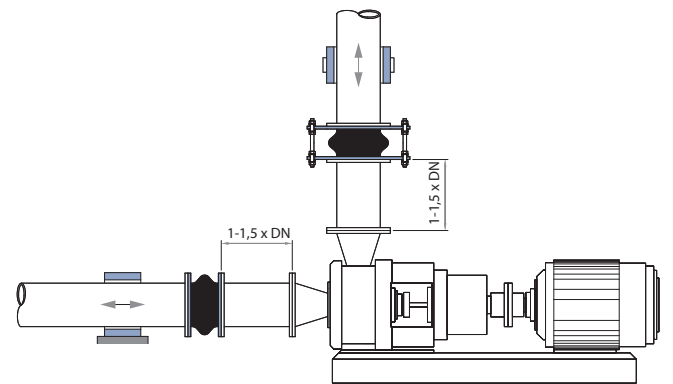

EB 8

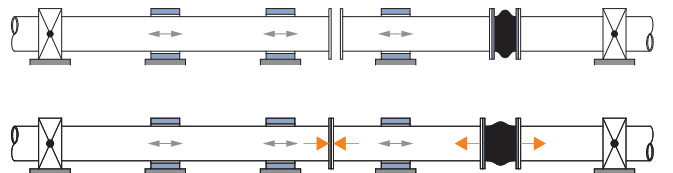

EB 8 a

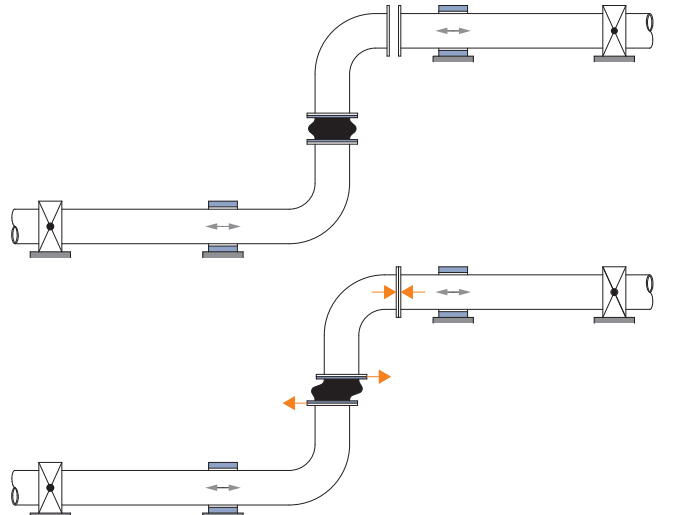

EB 9

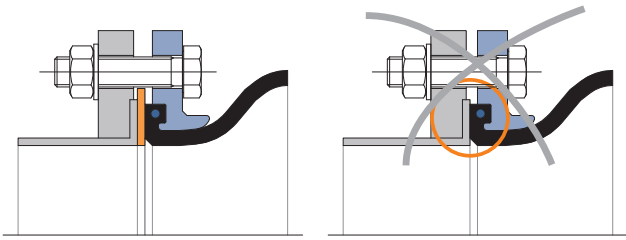

EB 10

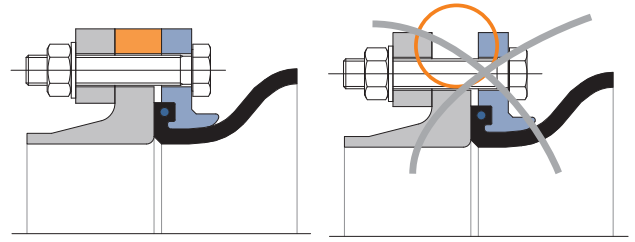

EB 10

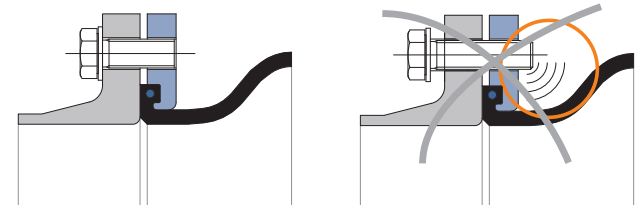
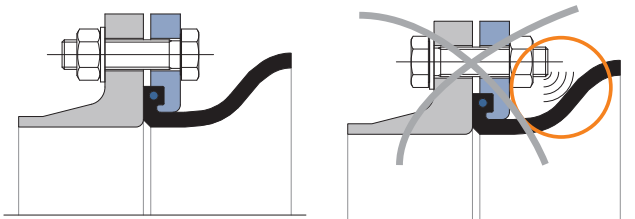
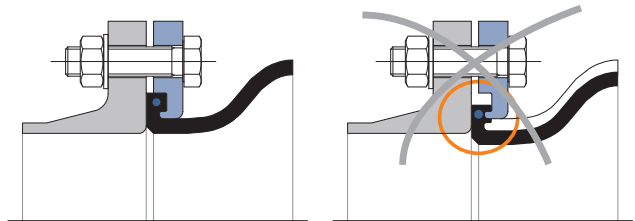
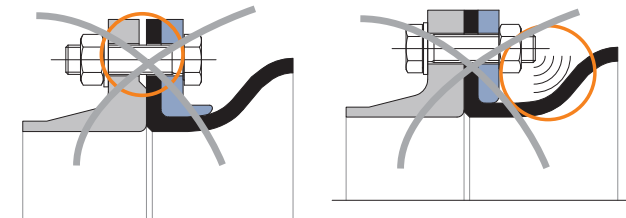
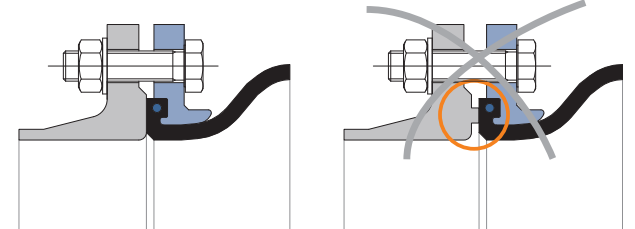
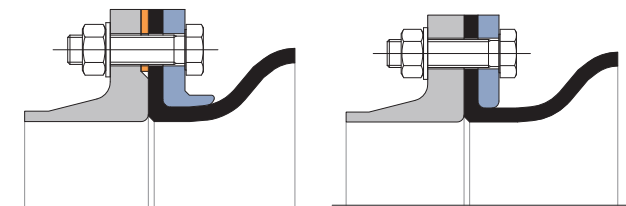
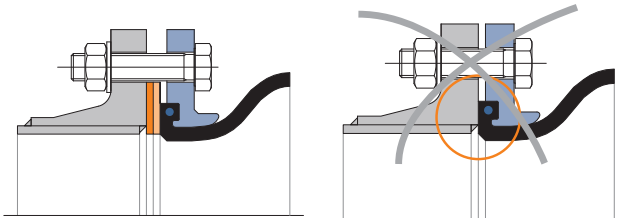
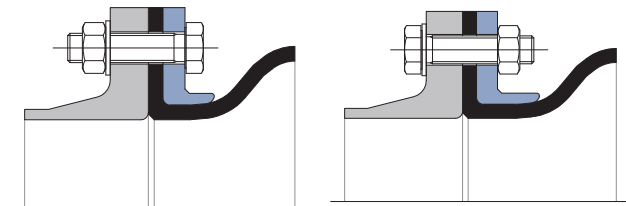
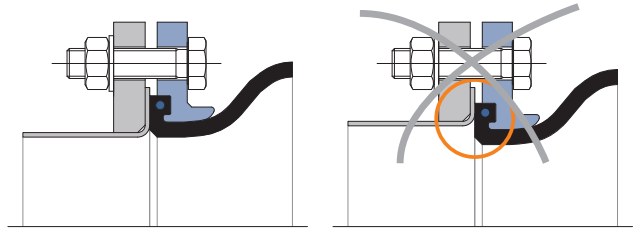
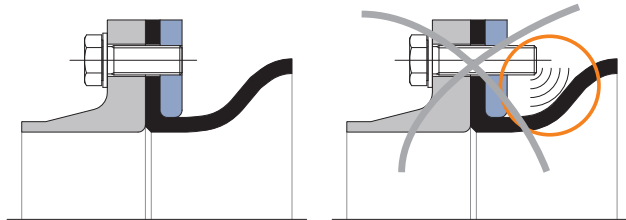

EB 11

DN 20/25 Typ 46 / DN 20 - 50 Typ 50

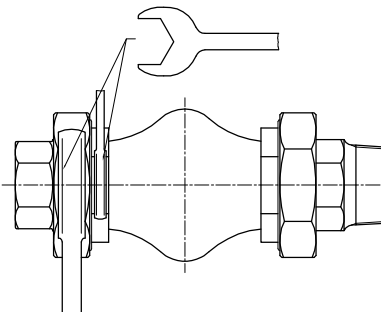
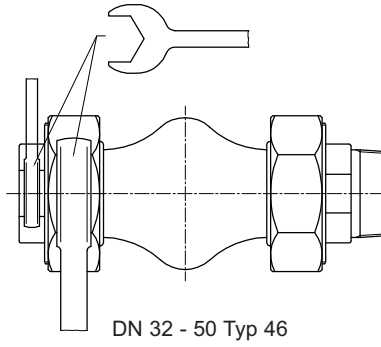

EB 14

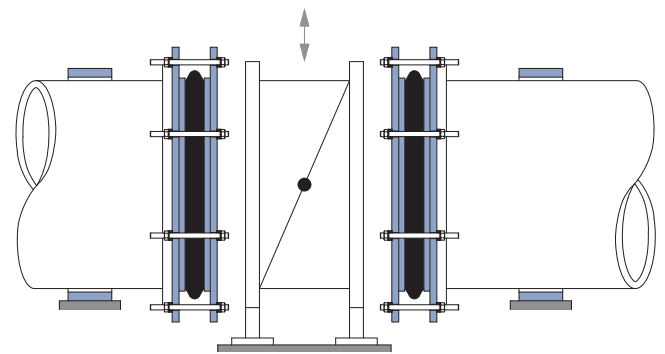
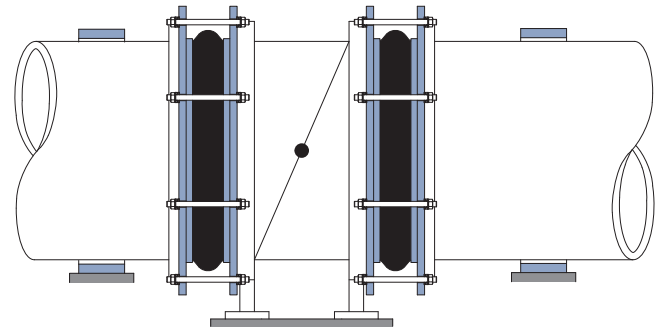

EB 12

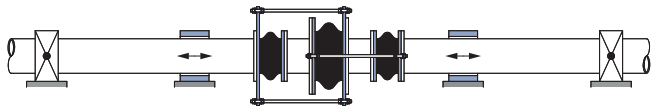

EB 15b

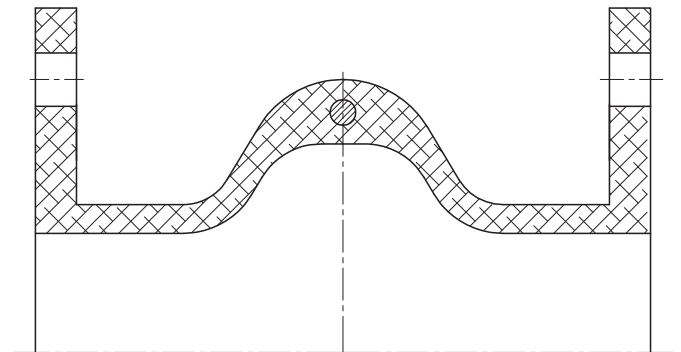

EB 13

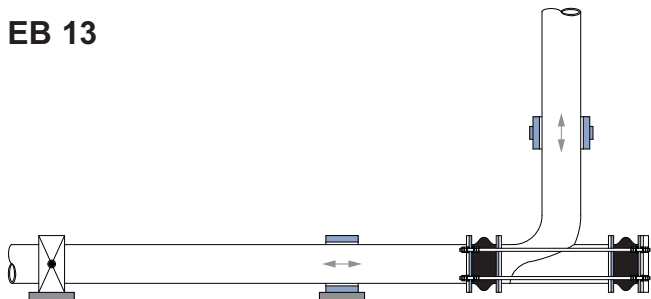

EB 15a

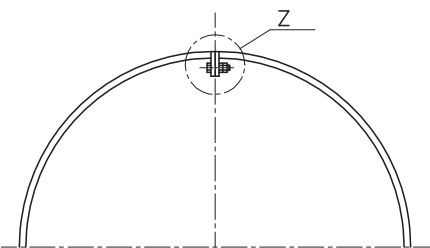

Detail Z

DN400 bis DN1100

ab DN1200 und >

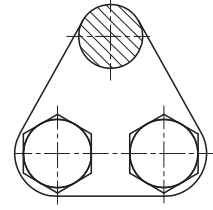
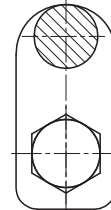
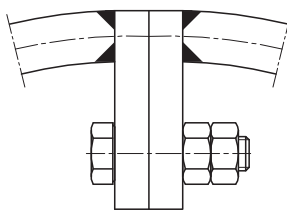

DN400 bis DN1100

ab DN1200 und >

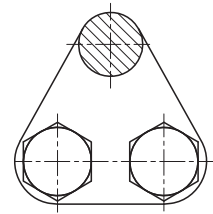
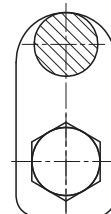
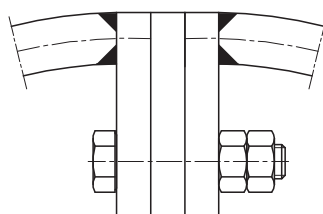

Flange Bolt Torque (Nm)

Installation information

Tools: Torque-wrench, rubber hammer, centre punches. All tools to be burr-free (danger of damage to rubber parts)

Use **flange bolts** with **property class 8.8** (new bolts, greased).

- Step I
 - a) insert all bolts and tighten equally by hand.
 - b) Fasten with about 3 crosswise and uniform turns at torque step I . Check gap width at outer edge of flange.
 - c) Settling time 30 minutes.
- Step II
 - d) Tighten all bolts crosswise by 3 turns as per table above or 2/3 of final torque. Check gap width.
 - e) Settling time > 60 minutes.
- Step III
 - f) Tighten crosswise 2 turns at final torque.
DO NOT TIGHTEN FURTHER!

Before test pressure: check torque 1 turn crosswise with final value (Step III).

Later inspections: follow service manual. Only tighten flange bolts to final value (Step III).

Flange tightening torque

The flange bolt torques given in the table provide a specific surface pressure of 7 N/mm² relative to the total surface of the compensator flange (use flanges without seal). Because of the temporary settling process in the rubber flange area the surface pressure falls under working conditions to some 50% of the final value (step III). The residual effective gripping and sealing force is completely sufficient and suitable for test pressures up to 16 bar (tensile stresses from over-expansion **are not permissible!**).

Attention: The maximum tightening torques given must not be substantially exceeded, since an excessive load causes a constant increase in the flow in elastomer and leads to destruction (crushing).

Torque: Rough estimation of the final tightening torque for special flanges

Rule of thumb

- M_A = $0.2 \cdot F_{VM} \cdot d_2$
- M_A = Bolt Tightening Torque
- d_2 = Screw Thread Flanks-Ø 1.4
- F_{VM} = Installation Prestress Force = $K_A \cdot F_{KL}$
- *KA = Tightening Factor ~ 1.4 greased, against a firm support
- KA = Experimental Value = 1.0 selected flow process in rubber flange
- FKL = Clamping Force, Contact Pressure 7 N/mm² for total flange surface for Type 40

$$F_{KL} = \left(\frac{\text{Flange } D^2 - DN^2}{4} \right) \times \pi \times \frac{\text{Contact Pressure x (N)}}{\text{Number of bolts}}$$

Flange Bolt Torque for Type 40, 42, 58, and 59 (table 1)

DN	Step 1	Step 3				Step 3			
	Pre-assembly	PN 6	PN 10	PN 16	ASA 150	PN 6	PN 10	PN 16	ASA 150
	Nm	Nm	Nm	Nm	Nm	Nm	Nm	Nm	Nm
200	100	160	200	160	200	200	250	200	250
250	100	160	160	200	200	200	200	250	250
300	150	160	160	240	280	200	200	300	350
350	150	200	160	200	360	250	200	250	450
400	150	160	240	280	320	200	300	350	400
450	150	200	160	280	360	250	200	350	450
500	150	160	240	360	360	200	300	450	450
550	200				400				500
600	200	240	320	520	480	300	400	650	600
650	200				440				550
700	200	240	320	440	440	300	400	550	550
750	250				480				600
800	250	320	440	560	640	400	550	700	800
850	250				600				750
900	250	360	440	520	640	450	550	650	800
950	250				720				900
1000	250	360	560	720	680	450	700	900	850
1050	250				720				900
1100	250				720				900
1150	250				720				900
1200	250	440	680	960	720	550	850	1200	900
1250	250				880				1100
1300	250				920				1150
1350	250				1000				1250
1400	250	560	840	1000	960	700	1050	1250	1200
1450	250				1040				1300
1500	250				1000				1250
1600	250	600	1120	1360	920	750	1400	1700	1150
1650	250				1160				1450
1800	250	680	1120	1360	1120	850	1400	1700	1400
1950	250				1320				1650
2000	250	840	1160	1560	1480	1050	1450	1950	1850
2100	250				1520				1900
2200	250	880	1480		1640	1100	1850		2050
2250	250				1840				2300
2400	250	920	1520		2040	1150	1900		2550
2550	250				2320				2900
2600	250	1120	1560		2560	1400	1950		3200
2700	250				2560				3200
2800	250				2680	1450	2050		3350
2850	250				2960				3700
3000	250	1160	1880		3200	1450	2350		4000

DN < 3000 - 5000 on request

Flange Bolt Torque for Type 48, 48, 50, 51, 53, 55, 56 and 65 (table 2)

DN	Step 1 for all	Step 2 for all	steü 3				
			PN 6 Nm	PN 10 Nm	PN 16 Nm	PN 25 Nm	ASA 150 Nm
25	by hand	50	60	80	80	80	80
32	by hand	50	60	80	80	80	80
40	by hand	50	60	80	80	80	80
50	by hand	50	60	80	80	80	80
65	by hand	50	60	80	80	80	80
80	by hand	50	60	80	80	80	80
100	by hand	50	80	100	100	100	100
125	by hand	50	80	100	100	100	100
150	by hand	50	80	100	100	100	100
175	by hand	50	90	100	100	100	100
200	by hand	50	90	100	100	100	100
250	by hand	50	90	100	100	110	100
300	by hand	50	100	110	110	110	100
350	by hand	50	120	130	135	165	110
400	by hand	50	120	140	155	200	140
450	by hand	50	140	145	165	200	145
500	by hand	50	120	145	170	200	145
600	by hand	100	185	210	255	280	210
700	by hand	100	200	225	300	300	230
800	by hand	100	235	300	360	410	300
900	by hand	100	235	300	360	415	300
1000	by hand	100	300	360	425	525	360

See installation information.