

Slamsamler og Trykktapsdiagram, Y-filter, fig. 821

Y-strainer and pressure drop diagram, fig. 821



Dimensjoner

DN 25 – DN 300

Trykkklasse

DN 25 – DN 150	PN10/PN16
DN 200 – DN 300	PN10

Temperaturområde

-10°C til +300°C

Funksjon og konstruksjon

Y-filter med utskiftbar filterinnsats.

Standard maskevidde: DN 25 - DN 50: 1,0
 DN 65 - DN 80: 1,25
 DN 100 - DN 300: 1,6

Andre maskestørrelser på forespørsel.

Anvendelsesområde

Installeres i et rørsystem for å oppta urenheter som kan skade ventiler og pumper. Y-filter skal helst monteres i horisontal posisjon med filterutløpet vendt nedover, men kan også monteres vertikalt når væsken strømmer ovenfra og ned.

Materialbeskrivelse

1. Hus	Støpejern EN-GJL-250
2. Lokk	Støpejern EN-GJL-250
3. Sil	Rustfritt X5CrNi 18-10
6. Plugg	Galvanisert stål
7. Pakning	Grafit

Anslutningsformer

Flenser PN 10/16
 Bygge lengder iht. DIN 3202 F1.

Dimensions

DN 25 – DN 300

Pressure rating

DN 25 – DN 150	PN10/PN16
DN 200 – DN 300	PN10

Temperature range

-10°C to +300°C

Features

Y-strainer with interchangeable strainer.

Standard mesh for: DN 25 – DN 50: 1,0
 DN 65 – DN 80: 1,25
 DN 100 – DN 300: 1,6

Other mesh sizes on request.

Range of application

Installed in pipe systems to avoid dirt and unwanted particles damaging valves and pumps. Y-strainer should be installed in a horizontal position, bonnet down, but can also be mounted in a vertical position when the flow direction is from up to down.

Materials

1. Body	Cast Iron EN-GJL 250
2. Bonnet	Cast Iron EN-GJL 250
3. Strainer	Stainless steel X5CrNi 18-10
6. Plug	Galvanized steel
7. Gasket	Graphite

Socket

Flanges acc. To PN10/16
 Face to face acc. to DIN 3202 F1.

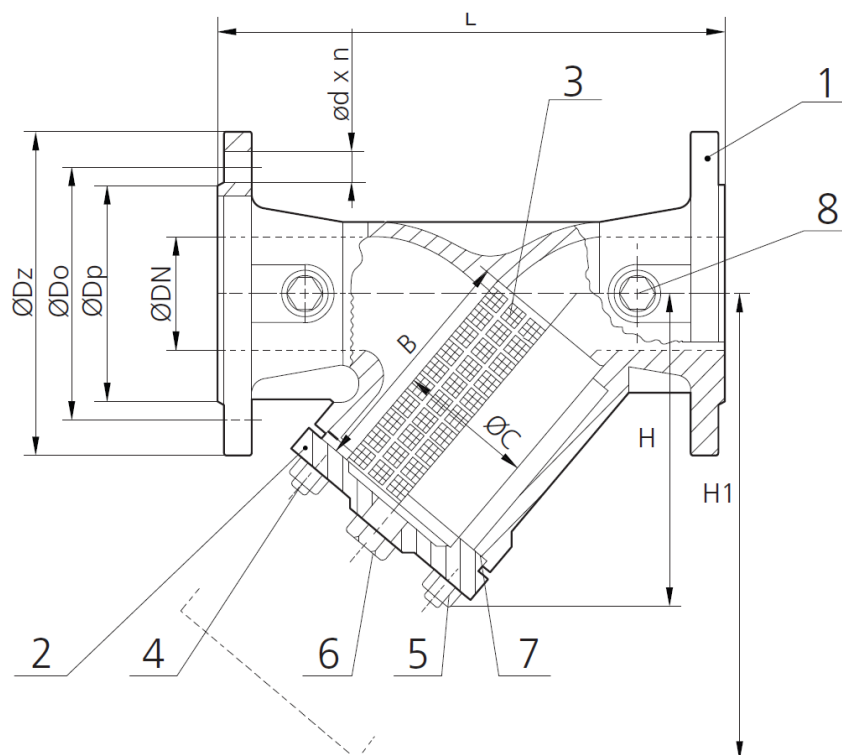
MÅLTABELL OG ARTIKKELNUMMER/MEASUREMENTS AND PART NO.

 Reservedeler pakning
 Spare parts gasket

DN	PN	L	Z	o	p	H	H1	C	B	nxdo	KG	NRF nr./Part No.	NRF nr./Part No.
25	10/16	160	115	85	65	115	180	36	82	4x14	4,3	4015733	4015753
32	10/16	180	140	100	76	135	215	42	98	4x19	6,8	4015734	4015754
40	10/16	200	150	110	84	150	240	50	114	4x19	9	4015735	4015755
50	10/16	230	165	125	99	160	250	61,5	119	4x19	11	4015736	4015756
65	10/16	290	185	145	118	180	285	78,5	134	4x19	14,6	4015737	4015757
80	10/16	310	200	160	132	215	330	89,5	149	8x19	18,6	4015738	4015758
100	10/16	350	220	180	156	235	365	109,5	169	8x19	27	4015739	4015759
125	10/16	400	250	210	184	280	425	137,5	199	8x19	38,5	4015741	4015761
150	10/16	480	285	240	211	320	480	160	224	8x23	54,5	4015742	4015762
200	10	600	340	295	266	405	610	210	284	8x23	110	4015743	4015763
250	10	730	405	355	319	540	915	258	434	12x28	165	4015744	4015764
300	10	850	460	410	370	680	1110	308	555	12x28	285	4015745	4015765

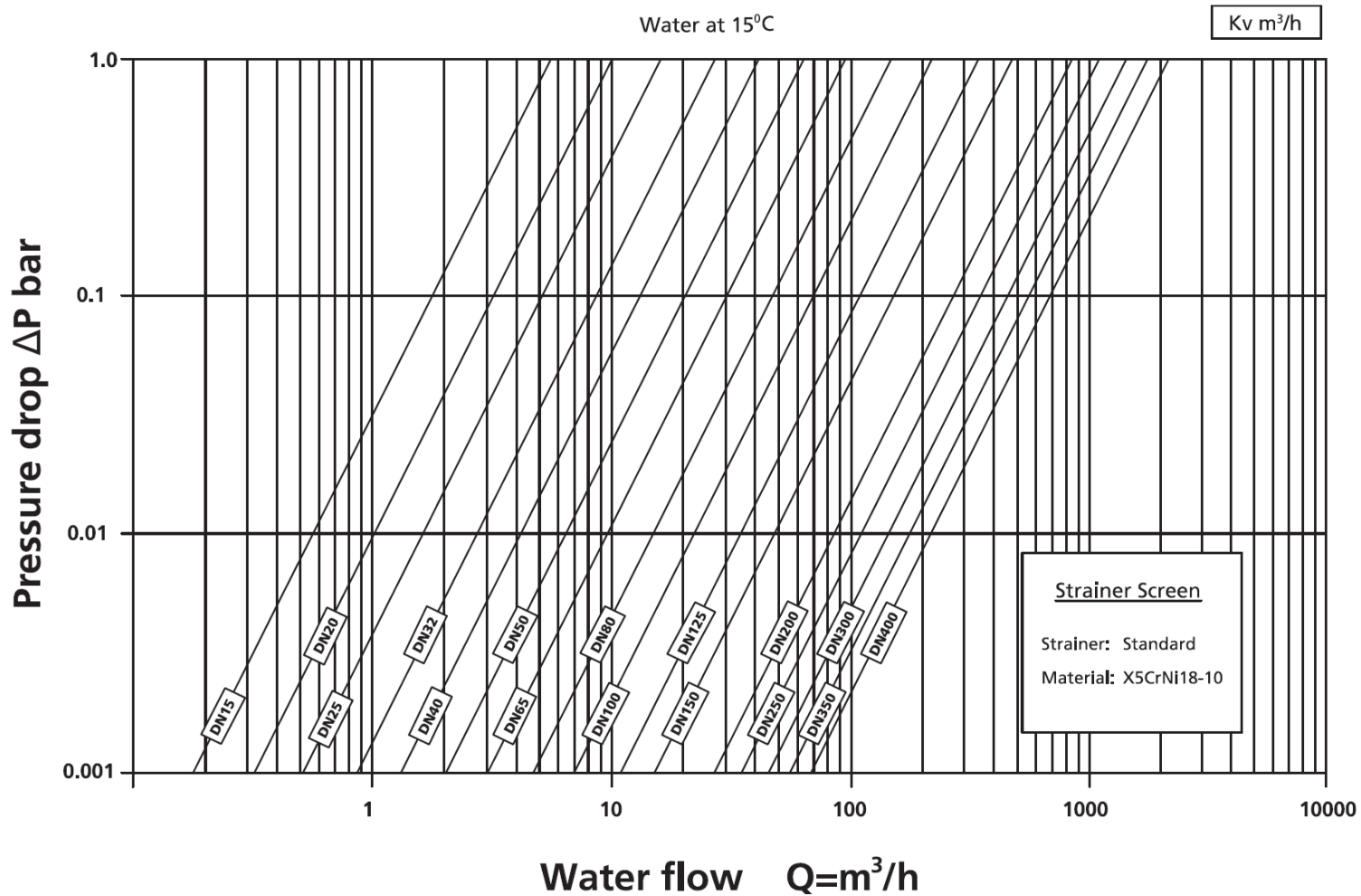

OBS!
Trykktapsdiagrammet gjelder for standard perforering.

NOTE!
Pressure drop diagram is for standard mesh dimensions