

TILBAKESLAGSVENTIL M/KLAFF OG FJÆR, TYPE ZRKF-VA-VA

Swing check valve with flap and spring, type ZRKF-VA-VA



Dimensjoner

DN 32 – DN 300

Trykkklasse

PN 16

Temperaturområde

-10°C til +90°C

Anvendelsesområde

For de fleste applikasjoner.
Tåler olje.

Materialbeskrivelse

Hus	Rustfritt stål AISI 316 Ti
Klaff	Rustfritt stål AISI 316 Ti
Fjær	Rustfritt stål AISI 316 Ti
Pakning	NBR

Dimensions

DN 32 – DN 300

Pressure range

PN 16

Temperature range

-10°C to +90°C

Range of applications

For most applications.
Tolerates oil.

Materials

Body	Stainless steel AISI 316 Ti
Flap	Stainless steel AISI 316 Ti
Feather	Stainless steel AISI 316 Ti
Packing	NBR

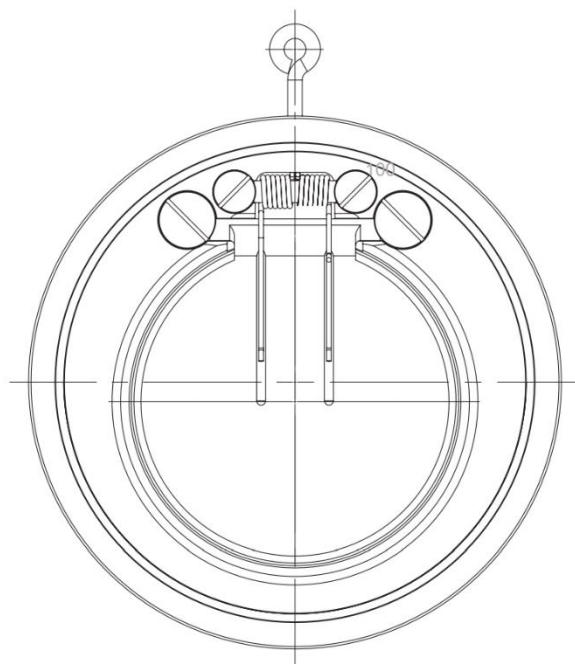
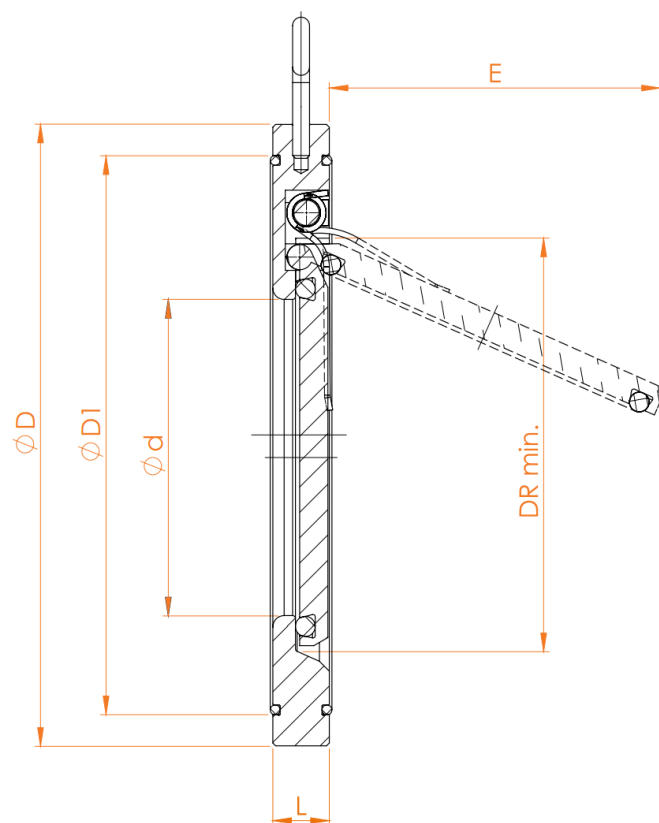
MÅLTABELL OG ARTIKKELNUMMER/MEASUREMENTS AND PART NO.

DN	L	$\varnothing d$	$\varnothing D1$	E	DR min.	KG	NRF nr./Part No.
32	15	18	59	22	37	0,67	5551715
40	16	22	72	25	43	0,85	5551716
50	14	32	86	37	54	0,91	5551717
65	14	40	109	50	70	1,23	5551718
80	14	54	119	61	82	1,5	5551719
100	18	70	146	77	106	2,42	5551721
125	18	92	173	98	131	3,34	5551722
150	20	112	197	120	159	4,61	5551723
200	22	154	255	160	207	7,68	5551724
250	26	192	312	190	260	13,4	5551725
300	32	227	363	220	309	21	5551726

Trykktapsdiagram for type ZRKF
 Pressure-loss diagram for type ZRKF

