

**Manufacturer:** Quick Bauprodukte GmbH  
**Test requirements:** Test instruction fibre concrete "Norwegian Standard"  
**Material / Mixture-No.:** Quick fiber concrete M1  
**Concrete quality:** C45/55  
**Exposure class concrete** acc. to Eurocode 2 (EC2) X0 / XC4 / XD 3 / XF4 / XA2

**Article / Article-No.:** Mounting-Bipo 40 without wire / 22034  
**Concrete cover:** 40 mm  
**Production date:** 27.11.2018  
**Test period:** 02.-05.01.2019

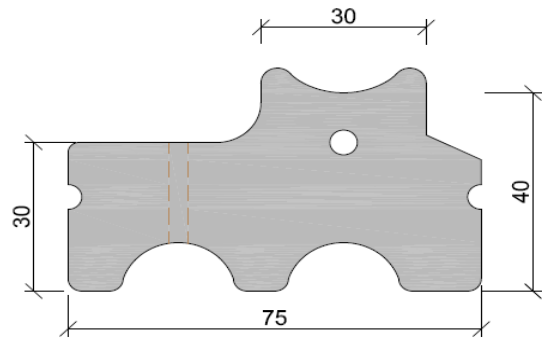

**Results dimension test**

Part No.	H	Vippediagonal
1	40,0	54,0
2	41,0	55,0
3	40,0	54,0
<b>mean</b>	<b>40,3</b>	<b>54,3</b>

**Results water absorption test**

Part No.	Storage weight in g after 48 hours heat treatment curing at +105°C	Weight in g after 30 min. immersion	Water content in % after 30 min. (to be < 5 %)	Weight in g after 24 hours immersion	Water content in % after 24 hours (to be < 8,5 %)
1	161	166	3,2%	171	6,7%
2	180	186	3,4%	193	7,1%
3	169	174	2,9%	181	6,6%
<b>mean</b>			<b>3,2%</b>		<b>6,8%</b>

**Results breaking load test**

Part No.	breaking load F / kN (to be >6 kN)
1	10,9
2	11,5
3	10,1
<b>mean</b>	<b>10,8</b>

This certificate complies to the requirements of DIN / EN 10204:2005-01-3.1

The buyer is not released from any entry control.  
 It is also irrelevant in case of incorrect use or handling.