



**Technical and Test Institute
for Construction Prague**
Prosecká 811/76a
190 00 Prague
Czech Republic
eota@tzus.cz



Member of



www.eota.eu

European Technical Assessment

**ETA 14/0138
of 20/05/2018**

Technical Assessment Body issuing the ETA: Technical and Test Institute
for Construction Prague

Trade name of the construction product

MO-H,
MO-HW,
MO-HS
steel bonded anchor

**Product family to which the construction
product belongs**

Product area code: 33
Bonded injection type anchor for use in
cracked and uncracked concrete

Manufacturer

Index Técnicas Expansivas, S.L.
P.I. La Portalada II C. Segador 13
26006 Logroño
Spain

Manufacturing plant

Index Plant 1

**This European Technical Assessment
contains**

19 pages including 15 Annexes which form
an integral part of this assessment.

**This European Technical Assessment is
issued in accordance with regulation
(EU) No 305/2011, on the basis of**

EAD 330499-00-0601

This version replaces

ETA 14/0138 issued on 17/03/2016

Translations of this European Technical Assessment in other languages shall fully correspond to the original issued document and should be identified as such.

Communication of this European Technical Assessment, including transmission by electronic means, shall be in full (excepted the confidential Annex(es) referred to above). However, partial reproduction may be made, with the written consent of the issuing Technical Assessment Body - Technical and Test Institute for Construction Prague. Any partial reproduction has to be identified as such.

1. Technical description of the product

The MO-H, MO-HW (faster curing time) and MO-HS (extended processing time) with steel elements is bonded anchor (injection type).

Steel elements can be galvanized or stainless steel threaded rod or rebar.

Steel element is placed into a drilled hole filled with injection mortar. The steel element is anchored via the bond between metal part, injection mortar and concrete. The anchor is intended to be used with embedment depth from 8 diameters to 20 diameters.

The illustration and the description of the product are given in Annex A.

2. Specification of the intended use in accordance with the applicable EAD

The performances given in Section 3 are only valid if the anchor is used in compliance with the specifications and conditions given in Annex B.

The provisions made in this European Technical Assessment are based on an assumed working life of the anchor of 50 years. The indications given on the working life cannot be interpreted as a guarantee given by the producer, but are to be regarded only as a means for choosing the products in relation to the expected economically reasonable working life of the works.

3. Performance of the product and references to the methods used for its assessment

3.1 Mechanical resistance and stability (BWR 1)

Essential characteristic	Performance
Static and quasi-static loading	
Resistance to steel failure (tension)	See Annex C1, C2
Resistance to combined pull-out and concrete failure	See Annex C1, C2
Resistance to concrete cone failure	See Annex C1, C2
Edge distance to prevent splitting under load	See Annex C1, C2
Robustness	See Annex C1, C2
Maximum setting torque moment	See Annex B4
Minimum edge distance and spacing	See Annex B4
Resistance to steel failure (shear)	See Annex C3, C4
Resistance to pry-out failure	See Annex C3, C4
Resistance to concrete edge failure	See Annex C3, C4
Displacements under short term and long term loading	See Annex C5, C6
Durability of metal parts	See Annex A3
Seismic performance C1	
Resistance to steel failure	See Annex C7
Resistance to pull-out	See Annex C7
Factor for annular gap	See Annex C7

3.2 Hygiene, health and environment (BWR 3)

No performance determined.

3.3 General aspects relating to fitness for use

Durability and serviceability are only ensured if the specifications of intended use according to Annex B 1 are kept.

4. Assessment and verification of constancy of performance (AVCP) system applied with reference to its legal base

According to the Decision 96/582/EC of the European Commission¹ the system of assessment verification of constancy of performance (see Annex V to Regulation (EU) No 305/2011) given in the following table apply.

Product	Intended use	Level or class	System
Metal anchors for use in concrete	For fixing and/or supporting to concrete, structural elements (which contributes to the stability of the works) or heavy units	-	1

5. Technical details necessary for the implementation of the AVCP system, as provided in the applicable EAD

5.1 Tasks of the manufacturer

The manufacturer may only use raw materials stated in the technical documentation of this European Technical Assessment.

The factory production control shall be in accordance with the control plan which is a part of the technical documentation of this European Technical Assessment. The control plan is laid down in the context of the factory production control system operated by the manufacturer and deposited at Technical and Test Institute for Construction Prague.² The results of factory production control shall be recorded and evaluated in accordance with the provisions of the control plan.

5.2 Tasks of the notified bodies

The notified body shall retain the essential points of its actions referred to above and state the results obtained and conclusions drawn in a written report.

The notified certification body involved by the manufacturer shall issue a certificate of constancy of performance of the product stating the conformity with the provisions of this European Technical Assessment.

In cases where the provisions of the European Technical Assessment and its control plan are no longer fulfilled the notified body shall withdraw the certificate of constancy of performance and inform Technical and Test Institute for Construction Prague without delay.

Issued in Prague on 20.05.2018

By

Ing. Mária Schaan

Head of the Technical Assessment Body

¹ Official Journal of the European Communities L 254 of 08.10.1996

² The control plan is a confidential part of the documentation of the European Technical Assessment, but not published together with the ETA and only handed over to the approved body involved in the procedure of AVCP.

Threaded rod

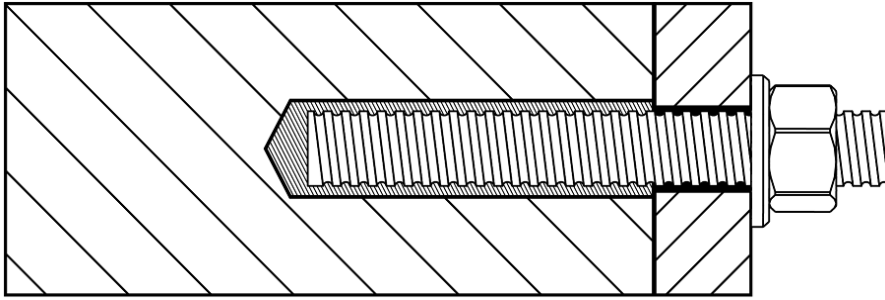

Reinforcing bar

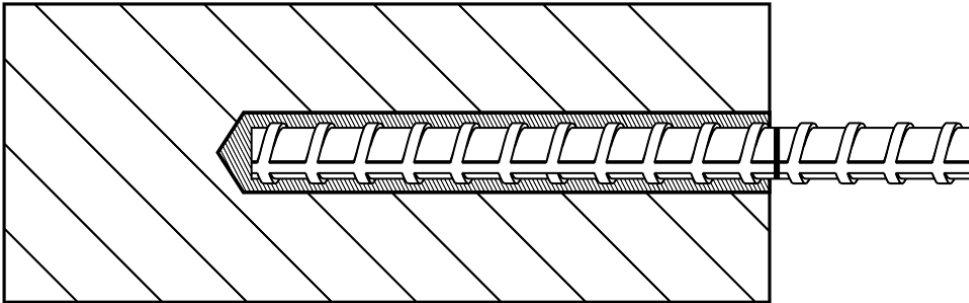

MO-H, MO-HW, MO-HS steel bonded anchor

Product description
Installed conditions

Annex A 1

Coaxial cartridge (CC)

MO-H, MO-HW, MO-HS

150 ml
380 ml
400 ml
410 ml



Side by side cartridge (SBS)

MO-H, MO-HW, MO-HS

350 ml
825 ml

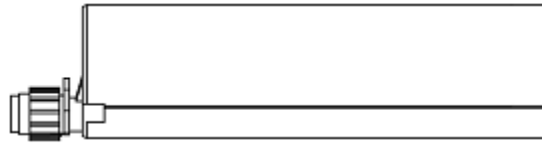

Two part foil in a single piston component cartridge (FCC)

MO-H, MO-HW, MO-HS

150 ml
170 ml
300 ml
550 ml
850 ml



Peeler cartridge (PLR)

MO-H, MO-HW, MO-HS

280 ml



Marking of the mortar cartridges

Identifying mark of the producer, Trade name, Charge code number, Storage life, Curing and processing time

Mixing nozzle

KW



RC

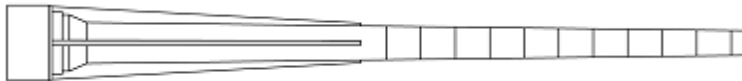

RM

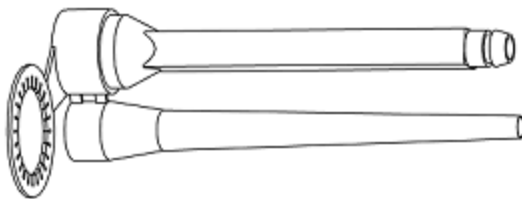

TB



KR for use with 850

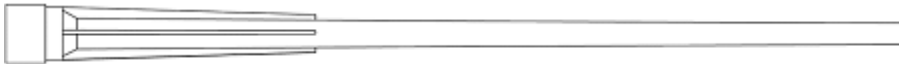

MO-H, MO-HW, MO-HS steel bonded anchor

Product description
Injection system

Annex A 2

Threaded rod M8, M10, M12, M16, M20, M24, M27, M30

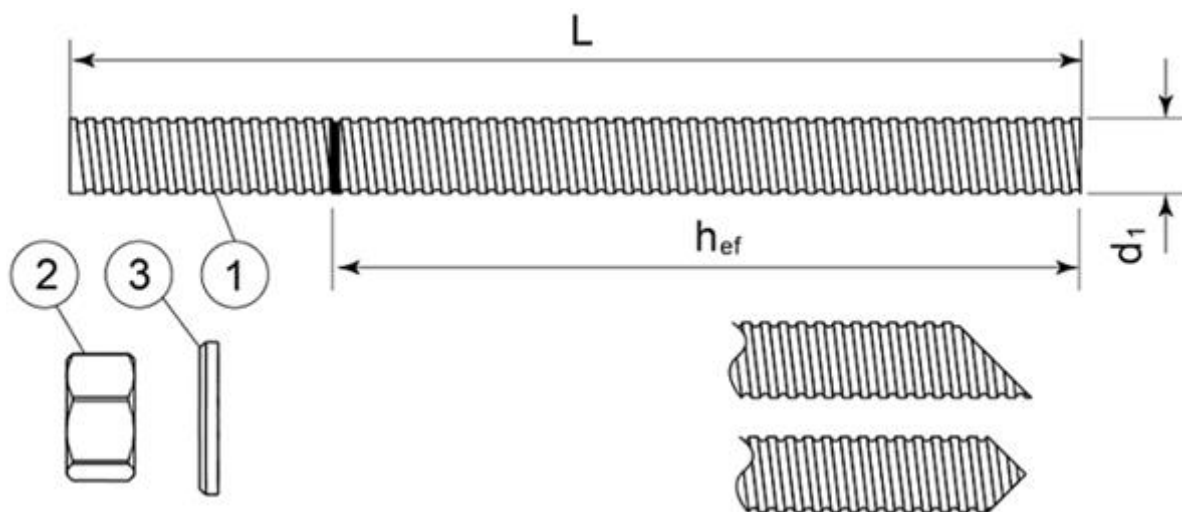

Standard commercial threaded rod with marked embedment depth

Part	Designation	Material
Steel, zinc plated $\geq 5 \mu\text{m}$ acc. to EN ISO 4042 or Steel, Hot-dip galvanized $\geq 40 \mu\text{m}$ acc. to EN ISO 1461 and EN ISO 10684 or Steel, zinc diffusion coating $\geq 15 \mu\text{m}$ acc. to EN 13811		
1	Anchor rod	Steel, EN 10087 or EN 10263 Property class 4.6, 5.8, 8.8, 10.9* EN ISO 898-1
2	Hexagon nut EN ISO 4032	According to threaded rod, EN 20898-2
3	Washer EN ISO 887, EN ISO 7089, EN ISO 7093 or EN ISO 7094	According to threaded rod
Stainless steel		
1	Anchor rod	Material: A2-70, A4-70, A4-80, EN ISO 3506
2	Hexagon nut EN ISO 4032	According to threaded rod
3	Washer EN ISO 887, EN ISO 7089, EN ISO 7093 or EN ISO 7094	According to threaded rod
High corrosion resistant steel		
1	Anchor rod	Material: 1.4529, 1.4565, EN 10088-1
2	Hexagon nut EN ISO 4032	According to threaded rod
3	Washer EN ISO 887, EN ISO 7089, EN ISO 7093 or EN ISO 7094	According to threaded rod

*Galvanized rod of high strength are sensitive to hydrogen induced brittle failure

MO-H, MO-HW, MO-HS steel bonded anchor

Product description
Threaded rod and materials

Annex A 3

Rebar Ø8, Ø10, Ø12, Ø16, Ø20, Ø25, Ø32



Standard commercial reinforcing bar with marked embedment depth

Product form		Bars and de-coiled rods	
Class		B	C
Characteristic yield strength f_{yk} or $f_{0,2k}$ (MPa)		400 to 600	
Minimum value of $k = (f_t/f_y)_k$		$\geq 1,08$	$\geq 1,15$ < 1,35
Characteristic strain at maximum force ϵ_{uk} (%)		$\geq 5,0$	$\geq 7,5$
Bendability		Bend/Rebend test	
Maximum deviation from nominal mass (individual bar) (%)	Nominal bar size (mm)	$\pm 6,0$ $\pm 4,5$	
	≤ 8 > 8		
Bond: Minimum relative rib area, $f_{R,min}$	Nominal bar size (mm)	0,040 0,056	
	8 to 12 > 12		

MO-H, MO-HW, MO-HS steel bonded anchor

Product description
Rebars and materials

Annex A 4

Specifications of intended use

Anchorage subject to:

- Static and quasi-static load.
- Seismic actions category C1 (max w = 0,5 mm): threaded rod size M10, M12, M16, M20, M24

Base materials

- Uncracked concrete.
- Cracked and uncracked concrete for threaded rod size M10, M12, M16, M20, M24
- Reinforced or unreinforced normal weight concrete of strength class C20/25 at minimum and C50/60 at maximum according EN 206-1:2000-12.

Temperature range:

- -40°C to +80°C (max. short. term temperature +80°C and max. long term temperature +50°C)

Use conditions (Environmental conditions)

- (X1) Structures subject to dry internal conditions (zinc coated steel, stainless steel, high corrosion resistance steel).
- (X2) Structures subject to external atmospheric exposure (including industrial and marine environment) and to permanently damp internal condition, if no particular aggressive conditions exist (stainless steel A4, high corrosion resistant steel).
- (X3) Structures subject to external atmospheric exposure and to permanently damp internal condition, if other particular aggressive conditions exist (high corrosion resistant steel).

Note: Particular aggressive conditions are e.g. permanent, alternating immersion in seawater or the splash zone of seawater, chloride atmosphere of indoor swimming pools or atmosphere with extreme chemical pollution (e.g. in desulphurization plants or road tunnels where de-icing materials are used).

Concrete conditions:

- I1 – installation in dry or wet (water saturated) concrete or flooded hole.
- I2 – installation in water-filled (not sea water) and use in service in dry or wet concrete

Design:

- The anchorages are designed in accordance with the EN 1992-4 or EOTA Technical Report TR 055 under the responsibility of an engineer experienced in anchorages and concrete work.
- Verifiable calculation notes and drawings are prepared taking account of the loads to be anchored. The position of the anchor is indicated on the design drawings.
- Anchorages under seismic actions (cracked concrete) have to be designed in accordance with EN 1992-4.

Installation:

- Hole drilling by hammer drill mode.
- Anchor installation carried out by appropriately qualified personnel and under the supervision of the person responsible for technical matters of the site.

Installation direction:

- D3 – downward and horizontal and upwards (e.g. overhead) installation

MO-H, MO-HW, MO-HS steel bonded anchor

Intended use
Specifications

Annex B 1

Applicator gun

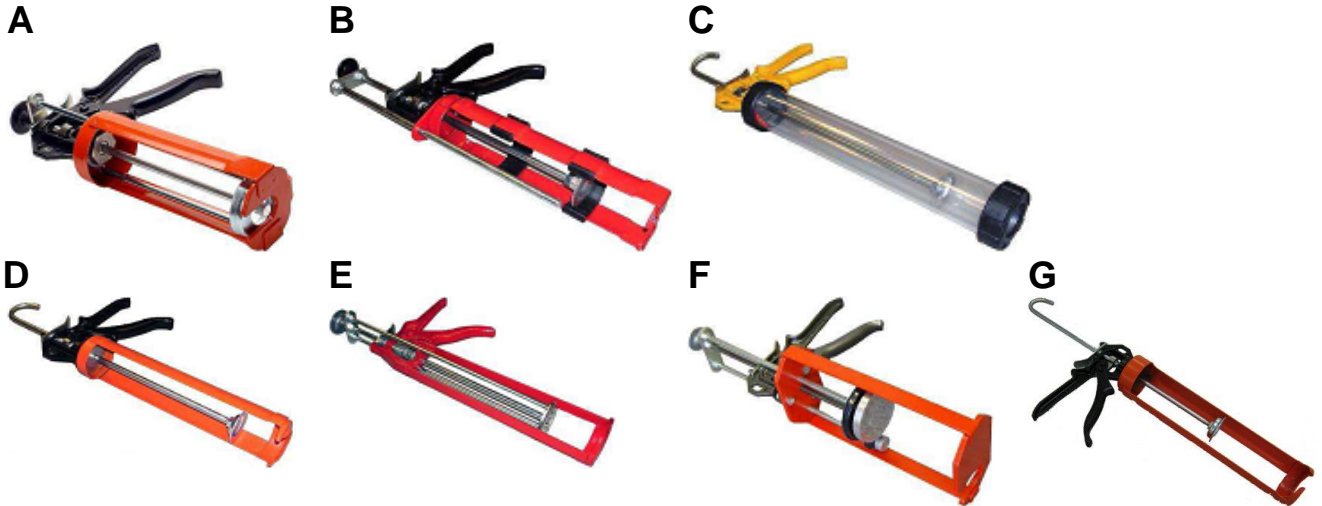

Applicator gun	A	B	C	D	E	F	G
Cartridge	Coaxial 380ml 400ml 410ml	Side by side 350ml	Foil capsule 150ml 300ml 550ml	Foil capsule 150ml 300ml Peeler 280ml	Coaxial 150ml	Side by side 825ml	Foil capsule 850ml

Cleaning brush

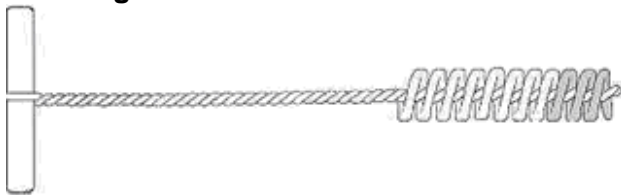

MO-H, MO-HW, MO-HS steel bonded anchor

Intended use
Applicator guns
Cleaning brush

Annex B 2

Installation instructions

1. Drill the hole to the correct diameter and depth using a rotary percussion drilling machine.
2. Thoroughly clean the hole in the following sequence using the brush with the required extensions and a blow pump:

Blow Clean x2.

Brush Clean x2.

Blow Clean x2.

Brush Clean x2.

Blow Clean x2.

Remove standing water from the hole prior to cleaning to achieve maximum performance.

3. Select the appropriate static mixer nozzle for the installation, open the cartridge/cut foil pack and screw nozzle onto the mouth of the cartridge. Insert the cartridge into a good quality applicator (gun).
4. Extrude the first part of the cartridge to waste until an even colour has been achieved without streaking in the resin.
5. If necessary, cut the extension tube to the depth of the hole and push onto the end of the mixer nozzle, and fit the correct resin stopper to the other end.
6. Insert the mixer nozzle (or the extension tube with resin stopper when necessary) to the bottom of the hole. Begin to extrude the resin and slowly withdraw the mixer nozzle from the hole ensuring that there are no air voids as the mixer nozzle is withdrawn. Fill the hole to approximately $\frac{1}{2}$ to $\frac{3}{4}$ full and withdraw the nozzle completely.
7. Insert the clean threaded bar, free from oil or other release agents, to the bottom of the hole using a back and forth twisting motion ensuring all the threads are thoroughly coated. Adjust to the correct position within the stated working time.
8. Excess resin will be expelled from the hole evenly around the steel element showing that the hole is full.
This excess resin should be removed from around the mouth of the hole before it sets.
9. Leave the anchor to cure.
Do not disturb the anchor until the appropriate loading time has elapsed depending on the substrate conditions and ambient temperature.
10. Attach the fixture and tighten the nut to the recommended torque.
Do not overtighten.

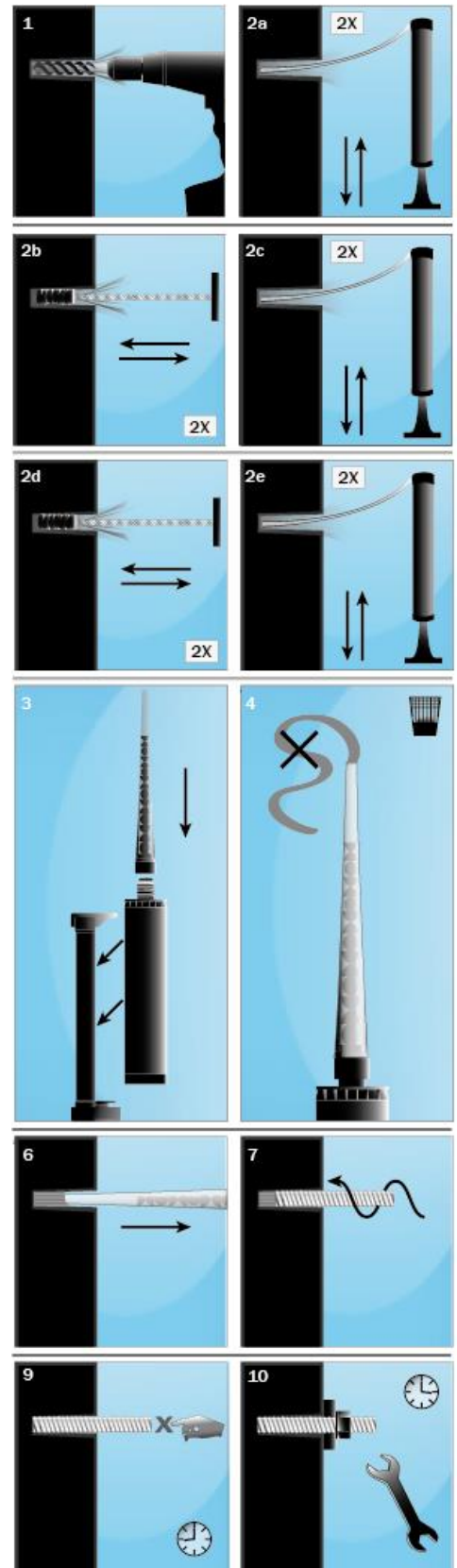

MO-H, MO-HW, MO-HS steel bonded anchor

Intended use
Installation procedure

Annex B 3

Table B1: Installation parameters of threaded rod

Size		M8	M10	M12	M16	M20	M24	M27	M30
Nominal drill hole diameter	$\varnothing d_0$ [mm]	10	12	14	18	22	26	30	35
Diameter of cleaning brush	d_b [mm]	14	14	20	20	29	29	40	40
Torque moment	$\max T_{fix}$ [Nm]	10	20	40	80	150	200	240	275
Depth of drill hole for $h_{ef,min}$	$h_0 = h_{ef}$ [mm]	64	80	96	128	160	192	216	240
Depth of drill hole for $h_{ef,max}$	$h_0 = h_{ef}$ [mm]	160	200	240	320	400	480	540	600
Minimum edge distance	c_{min} [mm]	35	40	50	65	80	96	110	120
Minimum spacing	s_{min} [mm]	35	40	50	65	80	96	110	120
Minimum thickness of member	h_{min} [mm]	$h_{ef} + 30 \text{ mm} \geq 100 \text{ mm}$				$h_{ef} + 2d_0$			

Table B2: Installation parameters of rebar

Size		$\varnothing 8$	$\varnothing 10$	$\varnothing 12$	$\varnothing 16$	$\varnothing 20$	$\varnothing 25$	$\varnothing 32$
Nominal drill hole diameter	$\varnothing d_0$ [mm]	12	14	16	20	25	32	40
Diameter of cleaning brush	d_b [mm]	14	14	19	22	29	40	42
Depth of drill hole for $h_{ef,min}$	$h_0 = h_{ef}$ [mm]	64	80	96	128	160	200	256
Depth of drill hole for $h_{ef,max}$	$h_0 = h_{ef}$ [mm]	160	200	240	320	400	500	640
Minimum edge distance	c_{min} [mm]	35	40	50	65	80	100	130
Minimum spacing	s_{min} [mm]	35	40	50	65	80	100	130
Minimum thickness of member	h_{min} [mm]	$h_{ef} + 30 \text{ mm} \geq 100 \text{ mm}$				$h_{ef} + 2d_0$		

Table B3: Cleaning

All diameters
- 2 x blowing
- 2 x brushing
- 2 x blowing
- 2 x brushing
- 2 x blowing

Table B4: Minimum curing time

MO-H		
Application temperature	Processing time	Load time
+5 to +10°C	10 mins	145 mins
+10 to +15°C	8 mins	85 mins
+15 to +20°C	6 mins	75 mins
+20 to +25°C	5 mins	50 mins
+25 to +30°C	4 mins	40 mins

Processing time refers to the highest temperature in the range.
Load time refers to the lowest temperature in the range.
Cartridge must be conditioned to a minimum +5°C.

MO-HW		
Application temperature	Processing time	Load time
0 to +5°C	10 mins	75 mins
+5 to +20°C	5 mins	50 mins
+20°C	100 second	20 mins

Processing time refers to the highest temperature in the range.
Load time refers to the lowest temperature in the range.
Cartridge must be conditioned to a minimum 0°C.

MO-HS		
Application temperature	Processing time	Load time
+15 to +20°C	15 mins	5 hours
+20 to +25°C	10 mins	145 mins
+25 to +30°C	7.5 mins	85 mins
+30 to +35°C	5 mins	50 mins
+35 to +40°C	3.5 mins	40 mins

Processing time refers to the highest temperature in the range.
Load time refers to the lowest temperature in the range.
Cartridge must be conditioned to a minimum +15°C.

MO-H, MO-HW, MO-HS steel bonded anchor

Intended use
Installation parameters
Curing time

Annex B 4

Table C1: Design method EN 1992-4

Characteristic values of resistance to tension load of threaded rod

Steel failure – Characteristic resistance										
Size			M8	M10	M12	M16	M20	M24	M27	M30
Steel grade 4.6	$N_{Rk,s}$	[kN]	15	23	34	63	98	141	184	224
Partial safety factor	γ_{Ms}	[-]	2,00							
Steel grade 5.8	$N_{Rk,s}$	[kN]	18	29	42	79	123	177	230	281
Partial safety factor	γ_{Ms}	[-]	1,50							
Steel grade 8.8	$N_{Rk,s}$	[kN]	29	46	67	126	196	282	367	449
Partial safety factor	γ_{Ms}	[-]	1,50							
Steel grade 10.9	$N_{Rk,s}$	[kN]	37	58	84	157	245	353	459	561
Partial safety factor	γ_{Ms}	[-]	1,33							
Stainless steel grade A2-70, A4-70	$N_{Rk,s}$	[kN]	26	41	59	110	172	247	321	393
Partial safety factor	γ_{Ms}	[-]	1,87							
Stainless steel grade A4-80	$N_{Rk,s}$	[kN]	29	46	67	126	196	282	367	449
Partial safety factor	γ_{Ms}	[-]	1,60							
Stainless steel grade 1.4529	$N_{Rk,s}$	[kN]	26	41	59	110	172	247	321	393
Partial safety factor	γ_{Ms}	[-]	1,50							
Stainless steel grade 1.4565	$N_{Rk,s}$	[kN]	26	41	59	110	172	247	321	393
Partial safety factor	γ_{Ms}	[-]	1,87							

Combined pullout and concrete cone failure in uncracked concrete C20/25											
Size			M8	M10	M12	M16	M20	M24	M27	M30	
Characteristic bond resistance in uncracked concrete											
Dry and wet concrete	$\tau_{Rk,ucr}$	[N/mm ²]	10	9,5	9,5	9	8,5	8	6,5	5,5	
Installation safety factor	$\gamma_2^{(1)} = \gamma_{inst}^{(2)}$	[-]	1,2							1,4	
Flooded hole	$\tau_{Rk,ucr}$	[N/mm ²]	8,5	7,5	7	7	6,5	5,5			
Installation safety factor	$\gamma_2^{(1)} = \gamma_{inst}^{(2)}$	[-]	1,4								
Factor for concrete C50/60	ψ_c	[-]	1								

Combined pullout and concrete cone failure in cracked concrete C20/25												
Size			M10	M12	M16	M20	M24					
Characteristic bond resistance in cracked concrete												
Dry and wet concrete	$\tau_{Rk,cr}$	[N/mm ²]	4,5	4,5	4,5	4	4					
Installation safety factor	$\gamma_2^{(1)} = \gamma_{inst}^{(2)}$	[-]	1,2									
Flooded hole	$\tau_{Rk,cr}$	[N/mm ²]	4,5	4,5	4,5	4	4					
Installation safety factor	$\gamma_2^{(1)} = \gamma_{inst}^{(2)}$	[-]	1,4									
Factor for cracked concrete	C30/37	ψ_c	[-]	1,12								
	C40/50			1,23								
	C50/60			1,30								

Concrete cone failure											
Factor for concrete cone failure for uncracked concrete	$k_1^{(1)}$	[-]	10,1								
	$k_{ucr,N}^{(2)}$		11								
Factor for concrete cone failure for cracked concrete	$k_1^{(1)}$	[-]	7,2								
	$k_{cr,N}^{(2)}$		7,7								
Edge distance	$c_{cr,N}$	[mm]	1,5 _{ef}								
Installation safety factor	$\gamma_2^{(1)} = \gamma_{inst}^{(2)}$	[-]	see Combined pullout and concrete cone failure								

Splitting failure										
Size			M8	M10	M12	M16	M20	M24	M27	M30
Edge distance	$c_{cr,sp}$	[mm]	1,5 _{ef}							
Spacing	$s_{cr,sp}$	[mm]	3,0 _{ef}							
Installation safety factor	$\gamma_2^{(1)} = \gamma_{inst}^{(2)}$	[-]	see Combined pullout and concrete cone failure							

¹⁾ Design according EOTA Technical Report TR 055

²⁾ Design according EN 1992-4:2016

MO-H, MO-HW, MO-HS steel bonded anchor

Performances

Design according to EN 1992-4

Characteristic resistance for tension loads - threaded rod

Annex C 1

Table C2: Design method EN 1992-4
Characteristic values of resistance to tension load of rebar

Steel failure – Characteristic resistance										
Size				Ø8	Ø10	Ø12	Ø16	Ø20	Ø25	Ø32
Rebar BSt 500 S	$N_{Rk,s}$	[kN]		28	43	62	111	173	270	442
Partial safety factor	γ_{Ms}	[-]		1,4						

Combined pullout and concrete cone failure in uncracked concrete C20/25										
Size				Ø8	Ø10	Ø12	Ø16	Ø20	Ø25	Ø32
Characteristic bond resistance in uncracked concrete										
Dry and wet concrete	$\tau_{Rk,ucr}$	[N/mm ²]		11	9,5	9,5	9	8,5	8,5	5,5
Installation safety factor	$\gamma_2^{(1)}=\gamma_{inst}^{(2)}$	[-]		1,2						
Flooded hole	$\tau_{Rk,ucr}$	[N/mm ²]		11	9,5	9,5	9	8,5	8,5	5,5
Installation safety factor	$\gamma_2^{(1)}=\gamma_{inst}^{(2)}$	[-]		1,4						
Factor for concrete C50/60	ψ_c	[-]		1						

Concrete cone failure									
Factor for concrete cone failure	$k_1^{(1)}$	[-]		10,1					
	$k_{ucr,N}^{(2)}$			11					
Edge distance	$c_{cr,N}$	[mm]		1,5h _{ef}					
Installation safety factor	$\gamma_2^{(1)}=\gamma_{inst}^{(2)}$	[-]		see Combined pullout and concrete cone failure					

Splitting failure										
Size				Ø8	Ø10	Ø12	Ø16	Ø20	Ø25	Ø32
Edge distance	$c_{cr,sp}$	[mm]		1,5h _{ef}						
Spacing	$s_{cr,sp}$	[mm]		3,0h _{ef}						
Installation safety factor	$\gamma_2^{(1)}=\gamma_{inst}^{(2)}$	[-]		see Combined pullout and concrete cone failure						

¹⁾ Design according EOTA Technical Report TR 055

²⁾ Design according EN 1992-4:2016

MO-H, MO-HW, MO-HS steel bonded anchor

Performances

Design according to EN 1992-4
Characteristic resistance for tension loads - rebar

Annex C 2

Table C3: Design method EN 1992-4
Characteristic values of resistance to shear load of threaded rod

Steel failure without lever arm											
Size			M8	M10	M12	M16	M20	M24	M27	M30	
Steel grade 4.6	$V_{Rk,s}$ [kN]		7	12	17	31	49	71	92	112	
Partial safety factor	γ_{Ms} [-]		1,67								
Steel grade 5.8	$V_{Rk,s}$ [kN]		9	15	21	39	61	88	115	140	
Partial safety factor	γ_{Ms} [-]		1,25								
Steel grade 8.8	$V_{Rk,s}$ [kN]		15	23	34	63	98	141	184	224	
Partial safety factor	γ_{Ms} [-]		1,25								
Steel grade 10.9	$V_{Rk,s}$ [kN]		18	29	42	79	123	177	230	281	
Partial safety factor	γ_{Ms} [-]		1,5								
Stainless steel grade A2-70, A4-70	$V_{Rk,s}$ [kN]		13	20	30	55	86	124	161	196	
Partial safety factor	γ_{Ms} [-]		1,56								
Stainless steel grade A4-80	$V_{Rk,s}$ [kN]		15	23	34	63	98	141	184	224	
Partial safety factor	γ_{Ms} [-]		1,33								
Stainless steel grade 1.4529	$V_{Rk,s}$ [kN]		13	20	30	55	86	124	161	196	
Partial safety factor	γ_{Ms} [-]		1,25								
Stainless steel grade 1.4565	$V_{Rk,s}$ [kN]		13	20	30	55	86	124	161	196	
Partial safety factor	γ_{Ms} [-]		1,56								
Characteristic resistance of group of fasteners											
Ductility factor $k_7 = 1,0$ for steel with rupture elongation $A_5 > 8\%$											

Steel failure with lever arm											
Size			M8	M10	M12	M16	M20	M24	M27	M30	
Steel grade 4.6	$M^o_{Rk,s}$ [N.m]		15	30	52	133	260	449	666	900	
Partial safety factor	γ_{Ms} [-]		1,67								
Steel grade 5.8	$M^o_{Rk,s}$ [N.m]		19	37	66	166	325	561	832	1125	
Partial safety factor	γ_{Ms} [-]		1,25								
Steel grade 8.8	$M^o_{Rk,s}$ [N.m]		30	60	105	266	519	898	1332	1799	
Partial safety factor	γ_{Ms} [-]		1,25								
Steel grade 10.9	$M^o_{Rk,s}$ [N.m]		37	75	131	333	649	1123	1664	2249	
Partial safety factor	γ_{Ms} [-]		1,50								
Stainless steel grade A2-70, A4-70	$M^o_{Rk,s}$ [N.m]		26	52	92	233	454	786	1165	1574	
Partial safety factor	γ_{Ms} [-]		1,56								
Stainless steel grade A4-80	$M^o_{Rk,s}$ [N.m]		30	60	105	266	519	898	1332	1799	
Partial safety factor	γ_{Ms} [-]		1,33								
Stainless steel grade 1.4529	$M^o_{Rk,s}$ [N.m]		26	52	92	233	454	786	1165	1574	
Partial safety factor	γ_{Ms} [-]		1,25								
Stainless steel grade 1.4565	$M^o_{Rk,s}$ [N.m]		26	52	92	233	454	786	1165	1574	
Partial safety factor	γ_{Ms} [-]		1,56								
Concrete pry-out failure											
Factor for resistance to pry-out failure	k_8 [-]						2				
Installation safety factor	$\gamma_2^{1)} = \gamma_{inst}^{2)}$ [-]						1,0				

Concrete edge failure											
Size			M8	M10	M12	M16	M20	M24	M27	M30	
Outside diameter of fastener	d_{nom} [mm]		8	10	12	16	20	24	27	30	
Effective length of fastener	l_f [mm]		min ($h_{ef}, 8 d_{nom}$)								
Installation safety factor	$\gamma_2^{1)} = \gamma_{inst}^{2)}$ [-]		1,0								

¹⁾ Design according EOTA Technical Report TR 055

²⁾ Design according EN 1992-4:2016

MO-H, MO-HW, MO-HS steel bonded anchor

Performances

Design according to EN 1992-4

Characteristic resistance for shear loads - threaded rod

Annex C 3

Table C4: Design method EN 1992-4
Characteristic values of resistance to shear load of rebar

Steel failure without lever arm								
Size		Ø8	Ø10	Ø12	Ø16	Ø20	Ø25	Ø32
Rebar BSt 500 S	$V_{Rk,s}$ [kN]	14	22	31	55	86	135	221
Partial safety factor	γ_{Ms} [-]	1,5						
Characteristic resistance of group of fasteners								
Ductility factor $k_7 = 1,0$ for steel with rupture elongation $A_5 > 8\%$								

Steel failure with lever arm								
Size		Ø8	Ø10	Ø12	Ø16	Ø20	Ø25	Ø32
Rebar BSt 500 S	$M^o_{Rk,s}$ [N.m]	33	65	112	265	518	1013	2122
Partial safety factor	γ_{Ms} [-]	1,5						
Concrete pry-out failure								
Factor for resistance to pry-out failure	k_8 [-]	2						
Installation safety factor	$\gamma_2^{(1)} = \gamma_{inst}^{(2)}$ [-]	1,0						

Concrete edge failure								
Size		Ø8	Ø10	Ø12	Ø16	Ø20	Ø25	Ø32
Outside diameter of fastener	d_{nom} [mm]	8	10	12	16	20	25	32
Effective length of fastener	l_f [mm]	min (h_{ef} , 8 d_{nom})						
Installation safety factor	$\gamma_2^{(1)} = \gamma_{inst}^{(2)}$ [-]	1,0						

¹⁾ Design according EOTA Technical Report TR 055

²⁾ Design according EN 1992-4:2016

MO-H, MO-HW, MO-HS steel bonded anchor	Annex C 4
Performances Design according to EN 1992-4 Characteristic resistance for shear loads - rebar	

Table C5: Displacement of threaded rod under tension and shear load

Anchor size			M8	M10	M12	M16	M20	M24	M27	M30
Uncracked concrete										
Tension load	F	[kN]	6,3	7,9	11,9	15,9	23,8	29,8	37,7	45,6
Displacement	δ_{N0}	[mm]	0,3	0,3	0,3	0,3	0,4	0,5	0,5	0,5
	$\delta_{N\infty}$	[mm]	0,5	0,5	0,5	0,5	0,5	0,5	0,5	0,5
Shear load	F	[kN]	3,1	5,0	7,2	13,5	21,0	30,3	39,4	48,0
Displacement	δ_{V0}	[mm]	1,5	1,5	1,5	1,5	2,0	2,5	2,5	2,5
	$\delta_{V\infty}$	[mm]	2,3	2,3	2,3	2,3	3,0	3,8	3,8	3,8
Cracked concrete										
Tension load	F	[kN]		5,1	7,4	13,1	20,5	24,6		
Displacement	δ_{N0}	[mm]		0,4	0,7	0,7	0,7	0,6		

MO-H, MO-HW, MO-HS steel bonded anchor

Performances
Displacement for threaded rod

Annex C 5

Table C6: Displacement of rebar under tension and shear load

Rebar size			Ø8	Ø10	Ø12	Ø16	Ø20	Ø25	Ø32
Uncracked concrete									
Tension load	F	[kN]	7,9	9,9	13,9	23,8	29,8	55,6	55,6
Displacement	δ_{N0}	[mm]	0,3	0,3	0,3	0,4	0,4	0,5	0,5
	$\delta_{N\infty}$	[mm]	0,5	0,5	0,5	0,5	0,5	0,5	0,5
Shear load	F	[kN]	5,9	9,3	13,3	23,7	37,0	57,9	94,8
Displacement	δ_{V0}	[mm]	0,3	0,4	0,4	0,4	0,4	0,5	0,9
	$\delta_{V\infty}$	[mm]	0,5	0,6	0,6	0,6	0,6	0,8	1,4

MO-H, MO-HW, MO-HS steel bonded anchor**Performances**
Displacement for rebar**Annex C 6**

Table C7: Characteristic values of resistance under seismic action category C1 for threaded rods

Size			M10	M12	M16	M20	M24
Tension load							
Steel failure							
Characteristic resistance grade 4.6	$N_{Rk,s,eq}$	[kN]	23	34	63	98	141
Partial safety factor	γ_{Ms}	[-]	2,00				
Characteristic resistance grade 5.8	$N_{Rk,s,eq}$	[kN]	29	42	79	123	177
Partial safety factor	γ_{Ms}	[-]	1,50				
Characteristic resistance grade 8.8	$N_{Rk,s,eq}$	[kN]	46	67	126	196	282
Partial safety factor	γ_{Ms}	[-]	1,50				
Characteristic resistance grade 10.9	$N_{Rk,s,eq}$	[kN]	58	84	157	245	353
Partial safety factor	γ_{Ms}	[-]	1,33				
Characteristic resistance A2-70, A4-70	$N_{Rk,s,eq}$	[kN]	41	59	110	172	247
Partial safety factor	γ_{Ms}	[-]	1,87				
Characteristic resistance A4-80	$N_{Rk,s,eq}$	[kN]	46	67	126	196	282
Partial safety factor	γ_{Ms}	[-]	1,60				
Characteristic resistance 1.4529	$N_{Rk,s,eq}$	[kN]	41	59	110	172	247
Partial safety factor	γ_{Ms}	[-]	1,50				
Characteristic resistance 1.4565	$N_{Rk,s,eq}$	[kN]	41	59	110	172	247
Partial safety factor	γ_{Ms}	[-]	1,87				
Combined pull-out and concrete cone failure							
Dry and wet concrete	$\tau_{Rk,p,eq,C1}$	[N/mm ²]	3,5	3,5	3,5	3,5	3,5
Installation safety factor	$\gamma_2^{(1)}=\gamma_{inst}^{(2)}$	[-]	1,2				
Flooded hole	$\tau_{Rk,p,eq,C1}$	[N/mm ²]	3,5	3,5	3,5	3,5	3,5
Installation safety factor	$\gamma_2^{(1)}=\gamma_{inst}^{(2)}$	[-]	1,4				
Shear load							
Steel failure without lever arm							
Characteristic resistance grade 4.6	$V_{Rk,s,eq}$	[kN]	7	10	23	30	40
Partial safety factor	γ_{Ms}	[-]	1,67				
Characteristic resistance grade 5.8	$V_{Rk,s,eq}$	[kN]	9	13	28	38	51
Partial safety factor	γ_{Ms}	[-]	1,25				
Characteristic resistance grade 8.8	$V_{Rk,s,eq}$	[kN]	14	21	45	61	81
Partial safety factor	γ_{Ms}	[-]	1,25				
Characteristic resistance grade 10.9	$V_{Rk,s,eq}$	[kN]	18	26	56	76	101
Partial safety factor	γ_{Ms}	[-]	1,50				
Characteristic resistance A2-70, A4-70	$V_{Rk,s,eq}$	[kN]	12	18	39	53	71
Partial safety factor	γ_{Ms}	[-]	1,56				
Characteristic resistance A4-80	$V_{Rk,s,eq}$	[kN]	14	21	45	61	81
Partial safety factor	γ_{Ms}	[-]	1,33				
Characteristic resistance 1.4529	$V_{Rk,s,eq}$	[kN]	12	18	39	53	71
Partial safety factor	γ_{Ms}	[-]	1,25				
Characteristic resistance 1.4565	$V_{Rk,s,eq}$	[kN]	12	18	39	53	71
Partial safety factor	γ_{Ms}	[-]	1,56				
Factor for annular gap	α_{gap}	[-]	0,5				

¹⁾ Design according EOTA Technical Report TR 055

²⁾ Design according EN 1992-4:2016

Note: Rebars are not qualified for seismic design

MO-H, MO-HW, MO-HS steel bonded anchor

Performances

Reduction factors for seismic design

Annex C 7