

Approval body for construction products
and types of construction

Bautechnisches Prüfamt

An institution established by the Federal and
Laender Governments



European Technical Assessment

ETA-17/0569
of 10 August 2017

English translation prepared by DIBt - Original version in German language

General Part

Technical Assessment Body issuing the
European Technical Assessment:

Deutsches Institut für Bautechnik

Trade name of the construction product

Wedge Anchor ESSVE ESA7

Product family
to which the construction product belongs

Torque controlled expansion anchor
for use in non-cracked concrete

Manufacturer

ESSVE Produkter AB
Esbogatan 14
164 74 KISTA
SCHWEDEN

Manufacturing plant

Production plant no. 516

This European Technical Assessment
contains

16 pages including 3 annexes which form an integral part
of this assessment

This European Technical Assessment is
issued in accordance with Regulation (EU)
No 305/2011, on the basis of

European Assessment Document (EAD)
330232-00-0601

The European Technical Assessment is issued by the Technical Assessment Body in its official language. Translations of this European Technical Assessment in other languages shall fully correspond to the original issued document and shall be identified as such.

Communication of this European Technical Assessment, including transmission by electronic means, shall be in full. However, partial reproduction may only be made with the written consent of the issuing Technical Assessment Body. Any partial reproduction shall be identified as such.

This European Technical Assessment may be withdrawn by the issuing Technical Assessment Body, in particular pursuant to information by the Commission in accordance with Article 25(3) of Regulation (EU) No 305/2011.

Specific Part

1 Technical description of the product

The Wedge Anchor ESSVE ESA7 in the range of M6, M8, M10, M12, M16 and M20 is an anchor made of electroplated, hot dipped galvanised steel, stainless steel or high corrosion resistant steel which is placed into a drilled hole and anchored by torque-controlled expansion. The product description is given in Annex A.

2 Specification of the intended use in accordance with the applicable European Assessment Document

The performances given in Section 3 are only valid if the anchor is used in compliance with the specifications and conditions given in Annex B. The verifications and assessment methods on which this European Technical Assessment is based lead to the assumption of a working life of the anchor of at least 50 years. The indications given on the working life cannot be interpreted as a guarantee given by the producer, but are to be regarded only as a means for choosing the right products in relation to the expected economically reasonable working life of the works.

3 Performance of the product and references to the methods used for its assessment

3.1 Mechanical resistance and stability (BWR 1)

Essential characteristic	Performance
Characteristic resistance	See Annex C 1 to C 3
Displacements under tension and shear loads	See Annex C 4

3.2 Safety in case of fire (BWR 2)

Essential characteristic	Performance
Reaction to fire	Anchorage satisfy requirements for Class A1
Resistance to fire	No performance assessed

4 Assessment and verification of constancy of performance (AVCP) system applied, with reference to its legal base

In accordance with European Assessment Documents EAD No. 330232-00-0601 the applicable European legal act is: [96/582/EC].
 The system to be applied is: 1

English translation prepared by DIBt

5 Technical details necessary for the implementation of the AVCP system, as provided for in the applicable European Assessment Document

Technical details necessary for the implementation of the AVCP system are laid down in the control plan deposited with Deutsches Institut für Bautechnik.

Issued in Berlin on 10 August 2017 by Deutsches Institut für Bautechnik

Andreas Kummerow
Head of Department

beglaubigt:
Baderschneider

Wedge Anchor ESSVE ESA7

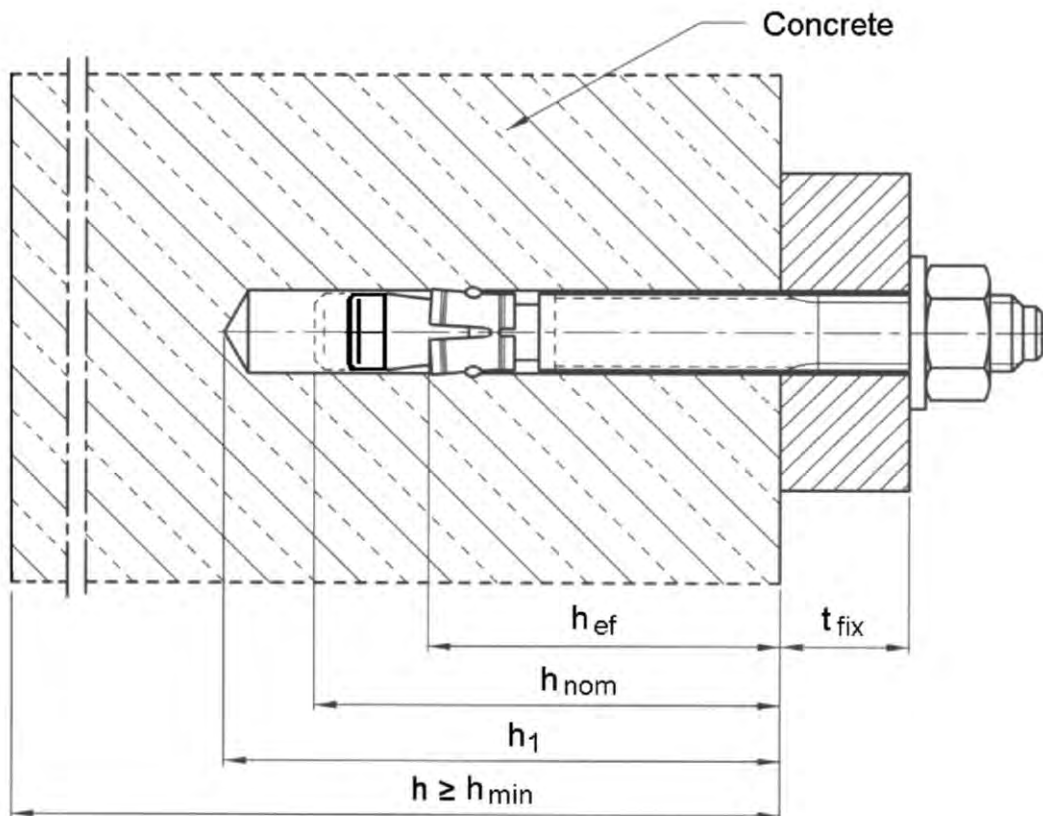
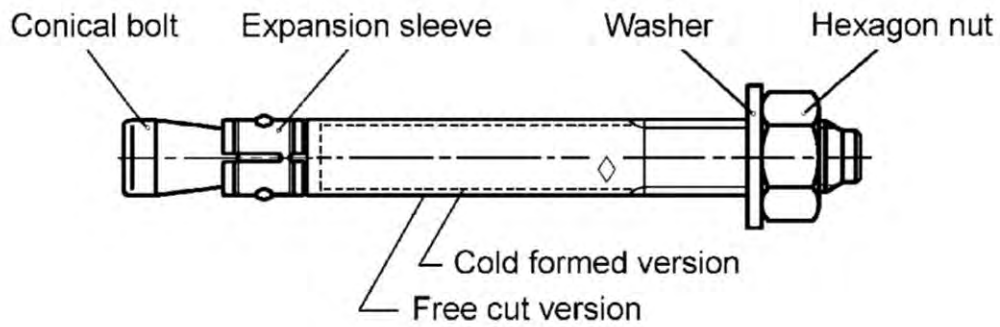

Wedge Anchor ESSVE ESA7

Product description
Installation situation

Annex A1

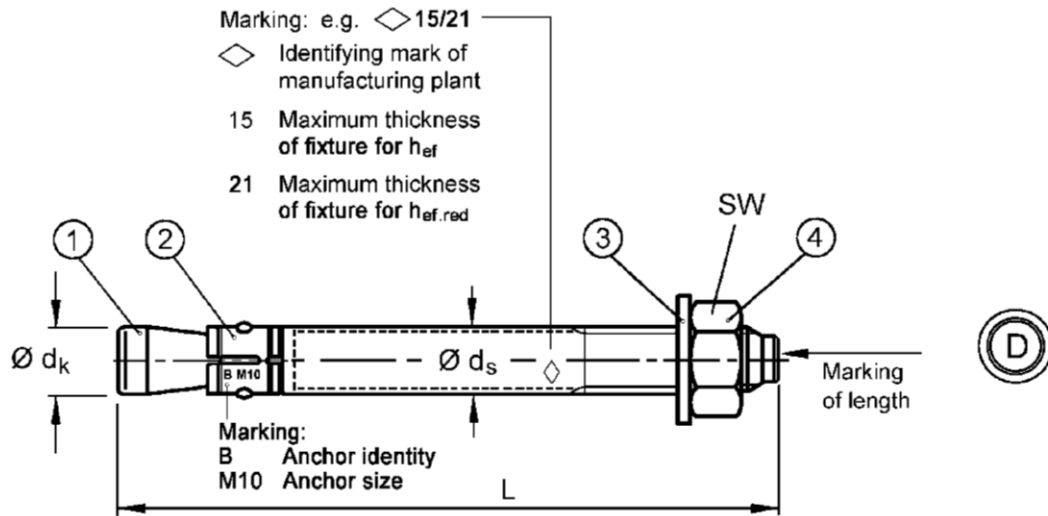

Marking of length	A	B	C	D	E	F	G	H	I	J	K	L	M
Length of anchor min \geq	38,1	50,8	63,5	76,2	88,9	101,6	114,3	127,0	139,7	152,4	165,1	177,8	190,5
Length of anchor max $<$	50,8	63,5	76,2	88,9	101,6	114,3	127,0	139,7	152,4	165,1	177,8	190,5	203,2

Marking of length	N	O	P	Q	R	S	T	U	V	W	X	Y	Z
Length of anchor min \geq	203,2	215,9	228,6	241,3	254,0	279,4	304,8	330,2	355,6	381,0	406,4	431,8	457,2
Length of anchor max $<$	215,9	228,6	241,3	254,0	279,4	304,8	330,2	355,6	381,0	406,4	431,8	457,2	483,0

Dimensions in mm

Table A1: Dimensions, steel zinc plated

Anchor size	$\varnothing d_k$	$\varnothing d_s$	Anchor length L		Wrench size [SW]
			Standard anchorage depth	Reduced anchorage depth	
Steel electroplated and hot-dip galvanised					
M6	6	6 / 5,3 ¹⁾	$t_{fix} + 57,4$	$t_{fix\ hef,red} + 47,4$	10
M8	8	8 / 7,1 ¹⁾	$t_{fix} + 66,4$	$t_{fix\ hef,red} + 57,4$	13
M10	10	10 / 8,9 ¹⁾	$t_{fix} + 74,0$	$t_{fix\ hef,red} + 68,0$	17
M12	12	12 / 10,7 ¹⁾	$t_{fix} + 97,3$	$t_{fix\ hef,red} + 82,3$	19
M16	16	16 / 14,5 ¹⁾	$t_{fix} + 121,0$	$t_{fix\ hef,red} + 103,0$	24
M20	20	20 / 18,2 ¹⁾	$t_{fix} + 142,7$	$t_{fix\ hef,red} + 120,7$	30

¹⁾ cold formed version

Table A2: Material properties, steel zinc plated

Part	Designation	Material	
		Steel, electroplated $\geq 5 \mu\text{m}$ acc. to EN ISO 4042:1999	Steel, hot-dip galvanised $\geq 40 \mu\text{m}$, acc. to EN ISO 1461:2009
1	Conical bolt	Cold formed or machined steel	Cold formed or machined steel
2	Expansion sleeve	Steel, acc. to EN 10088:2005, material No. 1.4301 or 1.4303	Steel, acc. to EN 10088:2005, material No. 1.4301 or 1.4303
3	Washer	Steel	Steel
4	Hexagon nut	Property class 8 acc. to EN ISO 898-2:2012	Property class 8 acc. to EN ISO 898-2:2012

Wedge Anchor ESSVE ESA7

Product description
Anchor dimensions, marking and materials, **steel zinc plated**

Annex A2

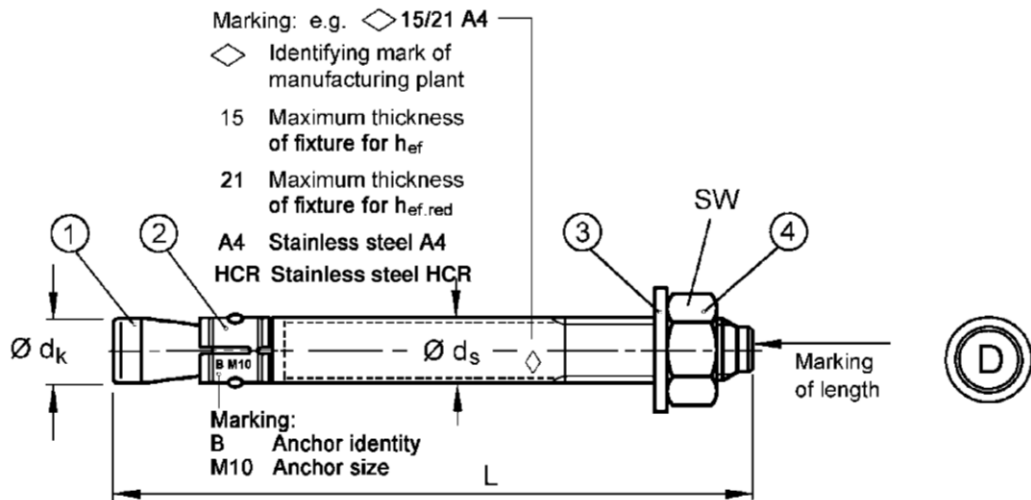

Marking of length	A	B	C	D	E	F	G	H	I	J	K	L	M
Length of anchor min \geq	38,1	50,8	63,5	76,2	88,9	101,6	114,3	127,0	139,7	152,4	165,1	177,8	190,5
Length of anchor max $<$	50,8	63,5	76,2	88,9	101,6	114,3	127,0	139,7	152,4	165,1	177,8	190,5	203,2

Marking of length	N	O	P	Q	R	S	T	U	V	W	X	Y	Z
Length of anchor min \geq	203,2	215,9	228,6	241,3	254,0	279,4	304,8	330,2	355,6	381,0	406,4	431,8	457,2
Length of anchor max $<$	215,9	228,6	241,3	254,0	279,4	304,8	330,2	355,6	381,0	406,4	431,8	457,2	483,0

Dimensions in mm

Table A3: Dimensions, stainless steel A4/HCR

Anchor size	$\varnothing d_k$	$\varnothing d_s$	Anchor length L		Wrench size [SW]
			Standard anchorage depth	Reduced anchorage depth	
Stainless steel A4/HCR					
M6	6	6 / 5,3 ¹⁾	$t_{fix} + 57,4$	$t_{fix, hef, red} + 47,4$	10
M8	8	8 / 7,1 ¹⁾	$t_{fix} + 66,4$	$t_{fix, hef, red} + 57,4$	13
M10	10	10 / 8,9 ¹⁾	$t_{fix} + 74,0$	$t_{fix, hef, red} + 68,0$	17
M12	12	12 / 10,7 ¹⁾	$t_{fix} + 96,5$	$t_{fix, hef, red} + 81,5$	19
M16	16	16 / 14,5 ¹⁾	$t_{fix} + 117,8$	$t_{fix, hef, red} + 101,8$	24
M20	19,7	19,7 / 18,2 ¹⁾	$t_{fix} + 142,7$	$t_{fix, hef, red} + 120,7$	30

¹⁾ cold formed version

Table A4: Designations and Materials, stainless steel A4/HCR

Part	Designation	Stainless steel A4	High corrosion resistant steel HCR
1	Conical bolt	Stainless steel 1.4401, 1.4404, 1.4571, 1.4578, 1.4362, EN 10088:2005, coated	High corrosion resistant steel 1.4529, 1.4565, EN 10088:2005, coated
2	Expansion sleeve	Stainless steel 1.4401, 1.4571, 1.4362, EN 10088:2005	
3	Washer	Stainless steel 1.4401, 1.4571, 1.4362, EN 10088:2005	High corrosion resistant steel 1.4529, 1.4565, EN 10088:2005
4	Hexagon nut	ISO 3506:2009, A4-70, stainless steel 1.4401, 1.4571, 1.4362, EN 10088:2005, coated	ISO 3506:2009, strength class 70, high corrosion resistant steel 1.4529, 1.4565, EN 10088:2005, coated

Wedge Anchor ESSVE ESA7

Product description

Anchor dimensions, marking and materials, **stainless steel A4/HCR**

Annex A3

Specifications of intended use

ESSVE ESA7		M6	M8	M10	M12	M16	M20
Materials	Steel zinc plated	electroplated	✓	✓	✓	✓	✓
		hot-dip galvanized	-	✓	✓	✓	✓
	Stainless steel	A4	✓	✓	✓	✓	✓
	High corrosion resistant steel	HCR	✓	✓	✓	✓	✓
Static or quasi-static action		✓					
Reduced anchorage depth		✓					
Non-cracked concrete		✓					

Base materials:

- Reinforced or unreinforced normal weight concrete according to EN 206-1:2000
- Strength classes C20/25 to C50/60 according to EN 206-1:2000

Use conditions (Environmental conditions):

- Structures subject to dry internal conditions (zinc plated steel, stainless steel or high corrosion resistant steel).
- Structures subject to external atmospheric exposure (including industrial and marine environment) and to permanently damp internal condition, if no particular aggressive conditions exist (stainless steel or high corrosion resistant steel).
- Structures subject to external atmospheric exposure and to permanently damp internal condition, if other particular aggressive conditions (high corrosion resistant steel).

Note: Particular aggressive conditions are e.g. permanent, alternating immersion in seawater or the splash zone of seawater, chloride atmosphere of indoor pools or atmosphere with extreme chemical pollution (e.g. in desulphurization plants or road tunnels where de-icing materials are used.)

Design:

- Anchorage are designed under the responsibility of an engineer experienced in anchorages and concrete work.
- Verifiable calculation notes and drawings are prepared taking account of the loads to be anchored. The position of the anchor is indicated on the design drawings (e.g. position of the anchor relative to reinforcement or to supports, etc.).
- Anchorage are designed according to FprEN 1992-4: 2016 and EOTA Technical Report TR 055.

Installation:

- Anchor installation carried out by appropriately qualified personnel and under the supervision of the person responsible for technical matters of the site.
- In case of aborted hole: new drilling at a minimum distance away of twice the depth of the aborted hole or smaller distance if the aborted drill hole is filled with high strength mortar and if under shear or oblique tension load it is not in the direction of load application.
- Anchor installation such that the effective anchorage depth is complied with. This compliance is ensured, if the thickness of fixture is not greater than the maximum thickness of fixture marked on the anchor in accordance with Annex A1 and A2 and the hexagon nut is placed at the end of the conical bolt as delivered by the manufacturer.

Wedge Anchor ESSVE ESA7

Intended use
Specifications

Annex B1

Table B1: Installation data, steel zinc plated

Anchor size		M6	M8	M10	M12	M16	M20
Nominal drill hole diameter	$d_0 =$ [mm]	6	8	10	12	16	20
Cutting diameter of drill bit	$d_{cut} \leq$ [mm]	6,40	8,45	10,45	12,5	16,5	20,55
Installation torque (ESSVE ESA7 electroplated)	$T_{inst} =$ [Nm]	8	15	30	50	100	200
Installation torque (ESSVE ESA7 hot-dip galvanised)	$T_{inst} =$ [Nm]	-	15	30	40	90	120
Diameter of clearance hole in the fixture	$d_f \leq$ [mm]	7	9	12	14	18	22
Standard anchorage depth							
Depth of drill hole	$h_1 \geq$ [mm]	55	65	70	90	110	130
Embedment depth	$h_{nom} \geq$ [mm]	49	56	62	82	102	121
Effective anchorage depth	$h_{ef} \geq$ [mm]	40	44	48	65	82	100
Reduced anchorage depth							
Depth of drill hole	$h_{1,red} \geq$ [mm]	45	55	65	75	95	110
Embedment depth	$h_{nom,red} \geq$ [mm]	39	47	56	67	84	99
Effective anchorage depth	$h_{ef,red} \geq$ [mm]	30	35	42	50	64	78

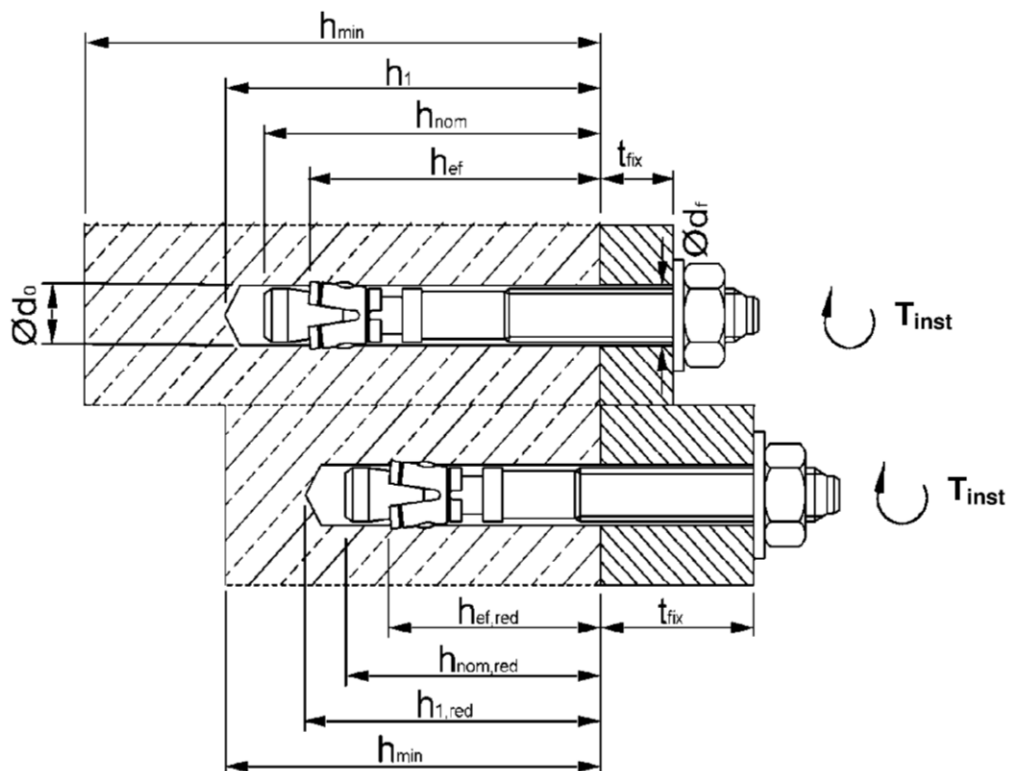

Wedge Anchor ESSVE ESA7

Intended use
Installation data, steel zinc plated

Annex B2

Table B2: Installation data, stainless steel A4/HCR

Anchor size		M6	M8	M10	M12	M16	M20
Nominal drill hole diameter	$d_0 =$ [mm]	6	8	10	12	16	20
Cutting diameter of drill bit	$d_{cut} \leq$ [mm]	6,40	8,45	10,45	12,5	16,5	20,55
Installation torque	$T_{inst} =$ [Nm]	6	15	25	50	100	160
Diameter of clearance hole in the fixture	$d_f \leq$ [mm]	7	9	12	14	18	22
Standard anchorage depth							
Depth of drill hole	$h_1 \geq$ [mm]	55	65	70	90	110	130
Embedment depth	$h_{nom} \geq$ [mm]	49	56	62	81	99	121
Effective anchorage depth	$h_{ef} \geq$ [mm]	40	44	48	65	80	100
Reduced anchorage depth							
Depth of drill hole	$h_{1,red} \geq$ [mm]	45	55	65	75	95	110
Embedment depth	$h_{nom,red} \geq$ [mm]	39	47	56	66	83	99
Effective anchorage depth	$h_{ef,red} \geq$ [mm]	30	35	42	50	64	78

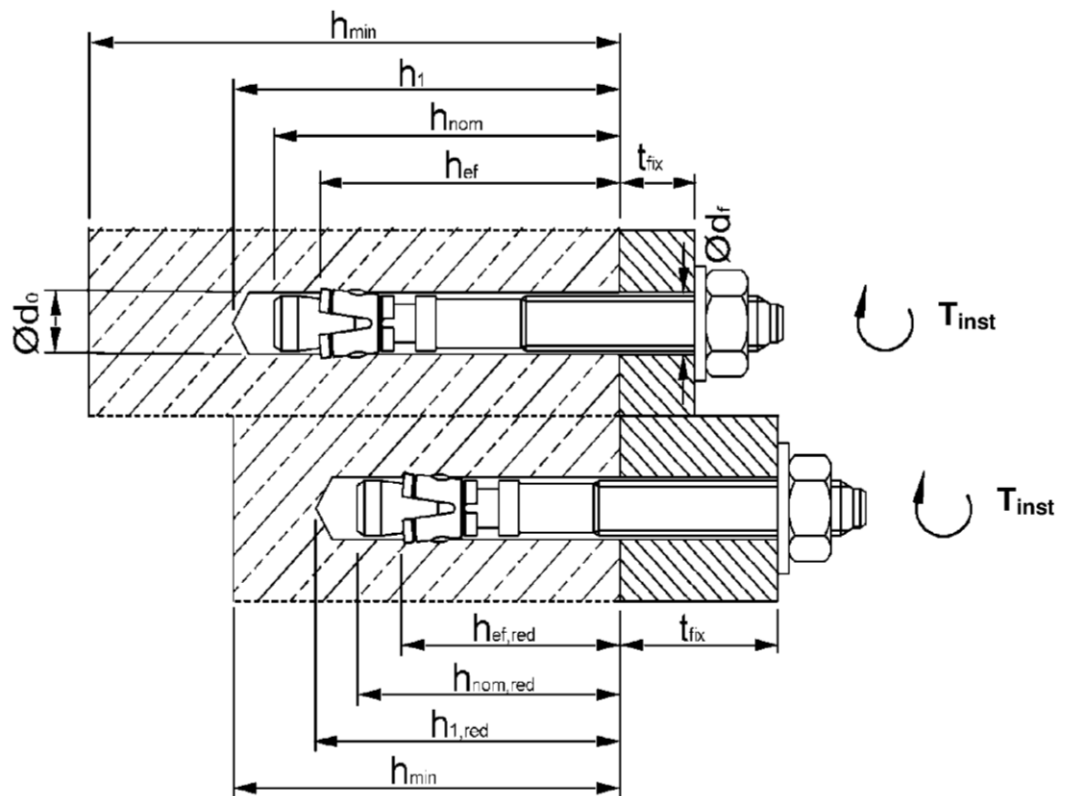

Wedge Anchor ESSVE ESA7

Intended use
Installation data, stainless steel A4/HCR

Annex B3

Table B3: Minimum spacings and edge distances, steel zinc plated

Anchor size			M6	M8	M10	M12	M16	M20
Standard anchorage depth h_{ef}								
Minimum member thickness	h_{min}	[mm]	100	100	100	130	170	200
Minimum spacing	s_{min}	[mm]	35	40	55	75	90	105
Minimum edge distance	c_{min}	[mm]	40	45	65	90	105	125
Reduced anchorage depth $h_{ef,red}$								
Minimum member thickness	h_{min}	[mm]	80	80	100	100	130	160
Minimum spacing	s_{min}	[mm]	35	40	55	100	100	140
Minimum edge distance	c_{min}	[mm]	40	45	65	100	100	140

Table B4: Minimum spacings and edge distances, stainless steel A4/HCR

Anchor size			M6	M8	M10	M12	M16	M20
Standard anchorage depth h_{ef}								
Minimum member thickness	h_{min}	[mm]	100	100	100	130	160	200
Minimum spacing	s_{min}	[mm]	35	35	45	60	80	100
	for $c \geq$	[mm]	40	65	70	100	120	150
Minimum edge distance	c_{min}	[mm]	35	45	55	70	80	100
	for $s \geq$	[mm]	60	110	80	100	140	180
Reduced anchorage depth $h_{ef,red}$								
Minimum member thickness	h_{min}	[mm]	80	80	100	100	130	160
Minimum spacing	s_{min}	[mm]	35	60	55	100	110	140
Minimum edge distance	c_{min}	[mm]	40	60	65	100	110	140

Intermediate values by linear interpolation.

Wedge Anchor ESSVE ESA7

Intended use
Minimum spacings and edge distances

Annex B4

Installation instructions

	<p>Drill hole perpendicular to concrete surface, positioning of the drill holes without damaging the reinforcement. In case of aborted hole: new drilling at a minimum distance away of twice the depth of the aborted hole or smaller distance if the aborted drill hole is filled with high strength mortar and if under shear or oblique tension load it is not in the direction of load application.</p>
	<p>Blow out dust.</p>
	<p>Check position of nut.</p>
	<p>Drive in anchor, such that h_{ef} or $h_{ef,red}$ is met. This is ensured, if the thickness of fixture is not greater than the maximum thickness of fixture marked on the anchor in accordance with Annex A2 and A3.</p>
	<p>Apply installation torque T_{inst} by using calibrated torque wrench.</p>

Wedge Anchor ESSVE ESA7

Intended use
Installation instructions

Annex B5

Table C1: Characteristic values for **tension loads, steel zinc plated**

Anchor size			M6	M8	M10	M12	M16	M20
Installation safety factor	γ_{inst}	[-]	1,0					
Steel failure								
Characteristic resistance	$N_{Rk,s}$	[kN]	8,7	15,3	26	35	65	107
Partial safety factor	γ_{Ms}	[-]	1,5				1,6	
Pull-out								
Standard anchorage depth h_{ef}								
Characteristic resistance in non-cracked concrete C20/25	$N_{Rk,p}$	[kN]	9	12	16	1)	1)	1)
Reduced anchorage depth $h_{ef,red}$								
Characteristic resistance in non-cracked concrete C20/25	$N_{Rk,p}$	[kN]	6 ²⁾	1) 2)	1)	1)	1)	1)
Increasing factor for $N_{Rk,p}$	ψ/C	[-]	$\left(\frac{f_{ck}}{20}\right)^{0,5}$					
Splitting								
Standard anchorage depth h_{ef}								
Spacing	$S_{cr,sp}$	[mm]	160	220	240	330	410	500
Edge distance	$C_{cr,sp}$	[mm]	80	110	120	165	205	250
Reduced anchorage depth $h_{ef,red}$								
Spacing	$S_{cr,sp}$	[mm]	180	210	230	240	320	400
Edge distance	$C_{cr,sp}$	[mm]	90	105	115	120	160	200
Concrete cone failure								
Standard anchorage depth h_{ef}								
Effective anchorage depth	$h_{ef} \geq$	[mm]	40	44	48	65	82	100
Spacing	$S_{cr,N}$	[mm]	3 h_{ef}					
Edge distance	$C_{cr,N}$	[mm]	1,5 h_{ef}					
Reduced anchorage depth $h_{ef,red}$								
Effective anchorage depth	$h_{ef,red} \geq$	[mm]	30 ²⁾	35 ²⁾	42	50	64	78
Spacing	$S_{cr,N}$	[mm]	3 $h_{ef,red}$					
Edge distance	$C_{cr,N}$	[mm]	1,5 $h_{ef,red}$					
Factor for k_1	$k_{ucr,N}$	[-]	11,0					

¹⁾ Pullout failure is not decisive

²⁾ Use restricted to anchorages of indeterminate structural components

Wedge Anchor ESSVE ESA7

Performance
Characteristic values for **tension loads, steel zinc plated**

Annex C1

Table C2: Characteristic values for tension loads, stainless steel A4/HCR

Anchor size			M6	M8	M10	M12	M16	M20
Installation safety factor	γ_{inst}	[-]	1,0					
Steel failure								
Characteristic resistance	$N_{Rk,s}$	[kN]	10	18	30	44	88	134
Partial safety factor	γ_{Ms}	[-]	1,50					
Pull-out								
Standard anchorage depth h_{ef}								
Characteristic resistance in non-cracked concrete C20/25	$N_{Rk,p}$	[kN]	7,5	12	16	25	1)	1)
Reduced anchorage depth $h_{ef,red}$								
Characteristic resistance in non-cracked concrete C20/25	$N_{Rk,p}$	[kN]	6 ²⁾	9 ²⁾	12	1)	1)	1)
Splitting								
Standard anchorage depth h_{ef}								
The higher one of the decisive resistances of Case 1 and Case 2 is applicable.								
Case 1								
Characteristic resistance in non-cracked concrete C20/25	$N^0_{Rk,sp}$	[kN]	6	9	12	20	30	40
Spacing	$S_{cr,sp}$	[mm]	3 h_{ef}					
Edge distance	$C_{cr,sp}$	[mm]	1,5 h_{ef}					
Case 2								
Characteristic resistance in non-cracked concrete C20/25	$N^0_{Rk,sp}$	[kN]	7,5	12	16	25	1)	1)
Spacing	$S_{cr,sp}$	[mm]	160	220	240	340	410	560
Edge distance	$C_{cr,sp}$	[mm]	80	110	120	170	205	280
Reduced anchorage depth $h_{ef,red}$								
Characteristic resistance in non-cracked concrete C20/25	$N^0_{Rk,sp}$	[kN]	6 ²⁾	9 ²⁾	12	1)	1)	1)
Spacing	$S_{cr,sp}$	[mm]	180	210	230	300	320	400
Edge distance	$C_{cr,sp}$	[mm]	90	105	115	150	160	200
Increasing factor for $N_{Rk,p}$ and $N^0_{Rk,sp}$	ψ_C	[-]	$\left(\frac{f_{ck}}{20}\right)^{0,5}$					
Concrete cone failure								
Standard anchorage depth								
Effective anchorage depth	h_{ef}	[mm]	40	44	48	65	80	100
Spacing	$S_{cr,N}$	[mm]	3 h_{ef}					
Edge distance	$C_{cr,N}$	[mm]	1,5 h_{ef}					
Reduced anchorage depth								
Effective anchorage depth	$h_{ef,red}$	[mm]	30 ²⁾	35 ²⁾	42	50	64	78
Spacing	$S_{cr,N}$	[mm]	3 h_{ef}					
Edge distance	$C_{cr,N}$	[mm]	1,5 h_{ef}					
Factor for k_1	$k_{ucr,N}$	[-]	11,0					

1) Pullout failure is not decisive.

2) Use restricted to anchorages of indeterminate structural components.

Wedge Anchor ESSVE ESA7

Performance
Characteristic values for tension loads, stainless steel A4/HCR

Annex C2

Table C3: Characteristic values for **shear loads, steel zinc plated**

Anchor size			M6	M8	M10	M12	M16	M20
Installation safety factor	γ_{inst}	[-]	1,0					
Steel failure without lever arm								
Characteristic shear resistance	$V_{Rk,s}$	[kN]	5	11	17	25	44	69
Factor for ductility	k_7	[-]	1,0					
Steel failure with lever arm								
Characteristic resistance	$M^0_{Rk,s}$	[Nm]	9	23	45	78	186	363
Partial safety factor for $V_{Rk,s}$ and $M^0_{Rk,s}$	γ_{Ms}	[-]	1,25			1,33		
Concrete pry-out failure								
Factor for h_{ef}	k_8	[-]	1,0	1,0	1,0	2,0	2,0	2,0
Factor for $h_{ef,red}$	k_8	[-]	1,0 ¹⁾	1,0 ¹⁾	1,0	1,0	2,0	2,0
Concrete edge failure								
Effective length of anchor in shear loading for h_{ef}	l_f	[mm]	40	44	48	65	82	100
Effective length of anchor in shear loading for $h_{ef,red}$	$l_{f,red}$	[mm]	30 ¹⁾	35 ¹⁾	42	50	64	78
Outside diameter of anchor	d_{nom}	[mm]	6	8	10	12	16	20

¹⁾ Use restricted to anchorages of indeterminate structural components

Table C4: Characteristic values for **shear loads, stainless steel A4/HCR**

Anchor Size			M6	M8	M10	M12	M16	M20
Installation safety factor	γ_{inst}	[-]	1,0					
Steel failure without lever arm								
Characteristic shear resistance	$V_{Rk,s}$	[kN]	7	12	19	27	50	86
Factor for ductility	k_7	[-]	1,0					
Steel failure with lever arm								
Characteristic bending moment	$M^0_{Rk,s}$	[Nm]	10	24	49	85	199	454
Partial safety factor for $V_{Rk,s}$ and $M^0_{Rk,s}$	γ_{Ms}	[-]	1,25			1,4		
Concrete pry-out failure								
Factor for h_{ef}	k_8	[-]	1,0	1,0	1,0	2,0	2,0	2,0
Factor for $h_{ef,red}$	k_8	[-]	1,0 ¹⁾	1,0 ¹⁾	1,0	1,0	2,0	2,0
Concrete edge failure								
Effective length of anchor in shear loading with h_{ef}	l_f	[mm]	40	44	48	65	80	100
Effective length of anchor in shear loading with $h_{ef,red}$	$l_{f,red}$	[mm]	30 ¹⁾	35 ¹⁾	42	50	64	78
Outside diameter of anchor	d_{nom}	[mm]	6	8	10	12	16	20

¹⁾ Use restricted to anchorages of indeterminate structural components

Wedge Anchor ESSVE ESA7

Performance
Characteristic values for **shear loads**

Annex C3

Table C5: Displacements under **tension loads, steel zinc plated**

Anchor size			M6	M8	M10	M12	M16	M20
Standard anchorage depth								
Tension load	N	[kN]	4,3	5,8	7,6	11,9	16,7	23,8
Displacement	δ_{N0}	[mm]	0,4	0,5				
	$\delta_{N\infty}$	[mm]	0,7	2,3				
Reduced anchorage depth								
Tension load	N	[kN]	2,9	5,0	6,5	8,5	12,3	16,6
Displacement	δ_{N0}	[mm]	0,3	0,4				
	$\delta_{N\infty}$	[mm]	0,6	1,8				

Table C6: Displacements under **tension loads, stainless steel A4/HCR**

Anchor size			M6	M8	M10	M12	M16	M20
Standard anchorage depth								
Tension load	N	[kN]	3,6	5,7	7,6	11,9	17,2	24,0
Displacement	δ_{N0}	[mm]	0,7	0,9	0,5	0,6	0,9	2,1
	$\delta_{N\infty}$	[mm]	1,8					4,2
Reduced anchorage depth								
Tension load	N	[kN]	2,9	4,3	5,7	8,5	12,3	16,6
Displacement	δ_{N0}	[mm]	0,4	0,7	0,4	0,4	0,6	1,5
	$\delta_{N\infty}$	[mm]	1,3					2,9

Table C7: Displacements under **shear loads, steel zinc plated**

Anchor size			M6	M8	M10	M12	M16	M20
Shear load	V	[kN]	2,9	6,3	9,7	14,3	23,6	37,0
Displacement	δ_{V0}	[mm]	1,2	1,5	1,6	2,6	3,1	4,4
	$\delta_{V\infty}$	[mm]	2,4	2,2	2,4	3,9	4,6	6,6

Table C8: Displacements under **shear loads, stainless steel A4/HCR**

Anchor Size			M6	M8	M10	M12	M16	M20
Shear load	V	[kN]	4,0	6,9	10,9	15,4	28,6	43,7
Displacement	δ_{V0}	[mm]	1,1	2,0	1,2	2,0	2,2	2,1
	$\delta_{V\infty}$	[mm]	1,7	3,0	1,8	3,0	3,3	3,2

Wedge Anchor ESSVE ESA7

Performance
Displacements

Annex C4