

TEKNISK DATABLAD

Stavrex jordskrue topp M16 ø65 mm



GRUNNLEGGENDE INFORMASJON

Artikkelnummer	C1095
Vekt (kg)	0,55
Materialer	Stål med varmforsinking, i henhold til DIN EN ISO 1461
Forutsatt bruk	Designet for å feste tilleggsdeler med M16-bolt
Kompatibilitet	Skruespiss / Serie A ø65 mm Forlengelser / Serie B ø65 mm Bjælkesko / Serie C M16-bolt

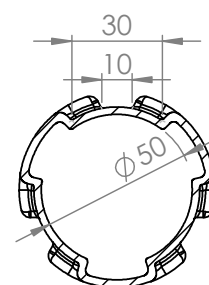
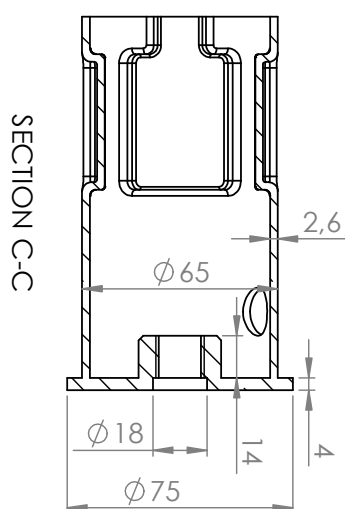
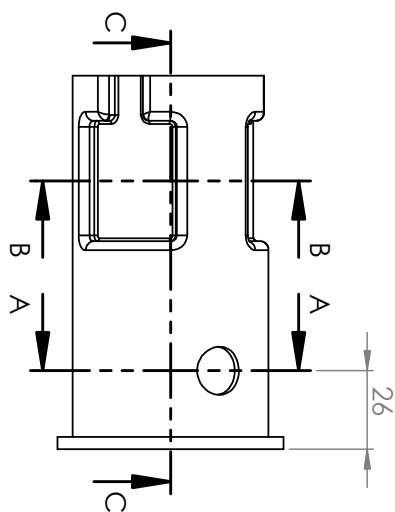

SECTION B-B

