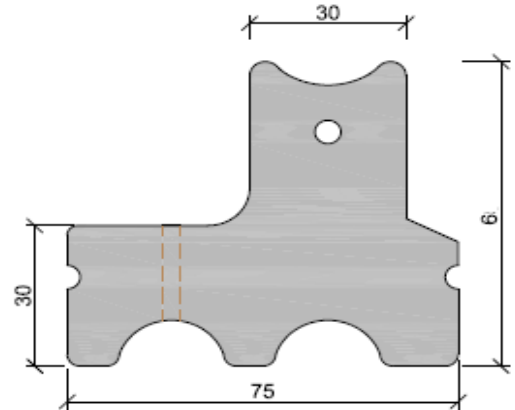

Manufacturer: Quick Bauprodukte GmbH
Test requirements: Test instruction fibre concrete "Norwegian Standard"
Material / Mixture-No.: Quick fiber concrete M1
Concrete quality: C45/55
Exposure class concrete: acc. to Eurocode 2 (EC2) X0 / XC4 / XD 3 / XF4 / XA2

Article / Article-No.: Mounting-Bipo 60 without wire / 22038
Concrete cover: 60 mm
Production date: 27.11.2019
Test period: 02.-05.01.2019

Results dimension test

Part No.	H	Vippediagonal
1	61,0	70,0
2	60,0	69,0
3	60,0	69,0
mean	60,3	69,3

Results water absorption test

Part No.	Storage weight in g after 48 hours heat treatment curing at +105°C	Weight in g after 30 min. immersion	Water content in % after 30 min. (to be < 5 %)	Weight in g after 24 hours immersion	Water content in % after 24 hours (to be < 8,5 %)
1	219	225	2,8%	232	5,9%
2	210	217	3,1%	223	6,3%
3	211	217	2,6%	223	5,7%
mean			2,8%		6,0%

Results breaking load test

Part No.	breaking load F / kN (to be >6 kN)
1	7,8
2	10,1
3	11,4
mean	9,8

This certificate complies to the requirements of DIN / EN 10204:2005-01-3.1

The buyer is not released from any entry control.
It is also irrelevant in case of incorrect use or handling.