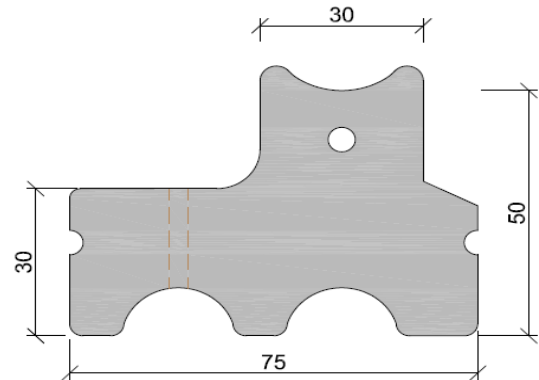

**Manufacturer:** Quick Bauprodukte GmbH  
**Test requirements:** Test instruction fibre concrete "Norwegian Standard"  
**Material / Mixture-No.:** Quick fiber concrete M1  
**Concrete quality:** C45/55  
**Exposure class concrete:** acc. to Eurocode 2 (EC2) X0 / XC4 / XD 3 / XF4 / XA2

**Article / Article-No.:** Mounting-Bipo 50 without wire / 22036  
**Concrete cover:** 50 mm  
**Production date:** 27.11.2018  
**Test period:** 02.-05.01.2019

**Results dimension test**

Part No.	H	Vippediagonal
1	50,0	61,0
2	50,0	61,0
3	50,0	60,0
<b>mean</b>	<b>50,0</b>	<b>60,7</b>

**Results water absorption test**

Part No.	Storage weight in g after 48 hours heat treatment curing at +105°C	Weight in g after 30 min. immersion	Water content in % after 30 min. (to be < 5 %)	Weight in g after 24 hours immersion	Water content in % after 24 hours (to be < 8,5 %)
1	200	207	3,5%	214	7,1%
2	198	206	3,7%	213	7,3%
3	198	205	3,5%	212	6,9%
<b>mean</b>			<b>3,6%</b>		<b>7,1%</b>

**Results breaking load test**

Part No.	breaking load F / kN (to be >6 kN)
1	11,6
2	10,1
3	9,7
<b>mean</b>	<b>10,5</b>

This certificate complies to the requirements of DIN / EN 10204:2005-01-3.1

The buyer is not released from any entry control.  
It is also irrelevant in case of incorrect use or handling.