

TEKNISK DATABLAD

Stavrex jordskrue forlenger 250 mm ø65 mm



GRUNNLEGGENDE INFORMASJON

Artikkelnummer	B1015
Vekt (kg)	1,1
Materialer	Stål med varmforsinking, i henhold til DIN EN ISO 1461
Forutsatt bruk	Designet for å forlenge skruespissen
Kompatibilitet	Skruespiss / Serie A ø65 mm Forlengelser / Serie B ø65 mm Topp / Serie C ø65 mm Monteringsmaskin 1:50/1:20 Håndverktøy til jordskrue

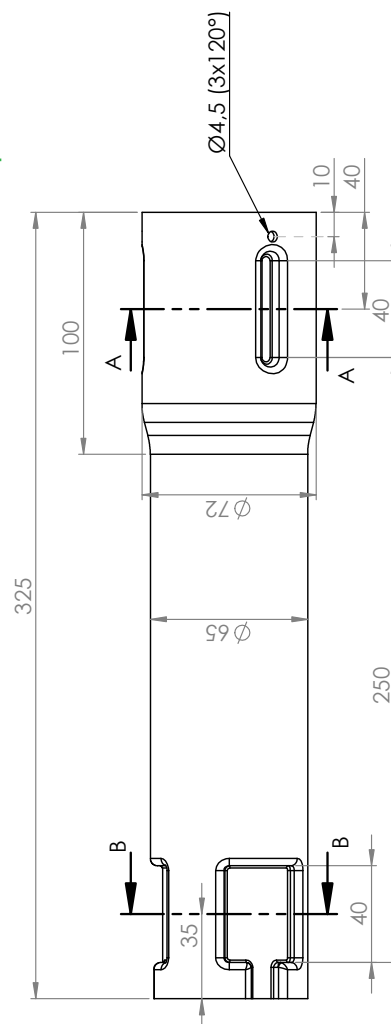
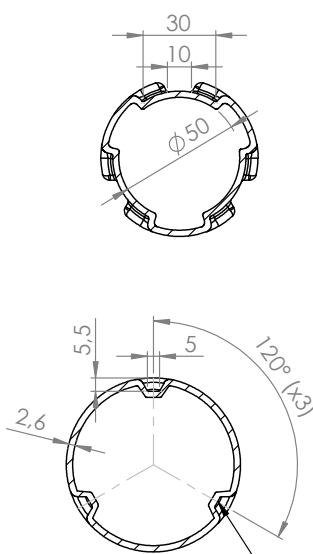

2296/CPR/2184