

## IS-SLT3-36-M20

**IS-SLT Intrinsically Safe**

The intrinsically safe and flameproof IS-SLT range provides surge protection for most twisted pair signal cables associated with intrinsically safe field devices.

**IEC Ex & ATEX Approved**

Novaris 'IS-SLT' products are certified intrinsically safe and flameproof according to IEC Ex and ATEX and so may be installed in Ex d rated instruments without loss of integrity.

**Multistage Design**

The multistage design provides a high energy gas discharge tube (GDT) as primary protection for common mode disturbances, commonly associated with lightning strikes and power system earth faults and a secondary metal-oxide varistor clamping stage across the signal lines. This combination provides very robust surge protection with high transient suppression and low let-through voltages. In addition protection is provided for cable screens which may be open circuit at the instrument.

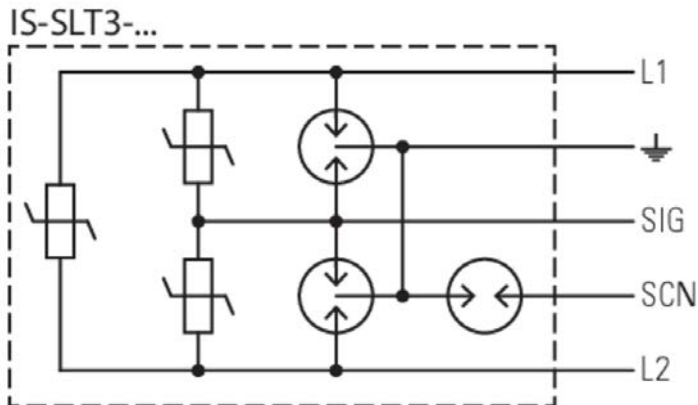
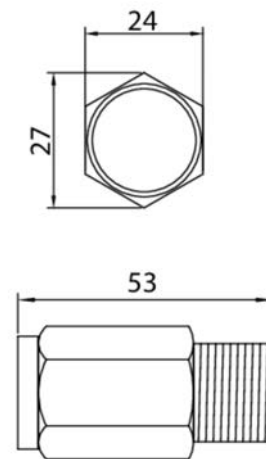
**Wiring****Dimensions**



M20 x 1.5 Thread Size

**Standards**

Directive 94/9/EC  
IEC 60079-0  
IEC 60079-1  
IEC 60079-11  
IEC 61643-21  
AS/NZS 1768  
UL 1449 & UL 497B  
ITU-T K.44

Equipment and protective systems intended for use in potentially explosive atmospheres  
Explosive atmospheres - Part 0: Equipment - General requirements  
Explosive atmospheres - Part 1: Equipment protection by flameproof enclosures 'd'  
Explosive atmospheres - Part 11: Equipment protection by intrinsic safety 'i'  
SPD connected to telecommunications and signalling networks - Cat C2, D1  
Signalling/Telecommunications surge protection  
Protectors for data communications and fire-alarm circuits  
Resistibility tests for telecommunication equipment exposed to overvoltages and overcurrents

## Electrical Specifications

Connection type		Shunt
Number of lines		1 pair + center
Modes of protection		Transverse & Common
Maximum continuous voltage (DC)	$U_c$	36V
Maximum continuous voltage (AC)	$U_c$	30V
Maximum discharge current (8/20 $\mu$ s)	$I_{max}$	5kA
Maximum common mode discharge current (8/20 $\mu$ s)		10kA
Impulse durability C2 10x8/20 $\mu$ s		2kA
Impulse durability D1 2x10/350 $\mu$ s		0.5kA
AC durability 5x1s		1Arms
Overstressed fault mode		Mode 1
Response time	$t_a$	<5ns
3 dB Frequency @ 150 $\Omega$		100kHz











## Electrical (L-L) Specifications

Voltage protection level @ 1 kV/ $\mu$ s	$U_p$	75V
Voltage protection level @ 100 V/ s		60V
Capacitance	- +	7nF

## Electrical (L-PE) Specifications

Voltage protection level @ 1 kV/ $\mu$ s	$U_p$	350V
Voltage protection level @ 100 V/ s		230V
Capacitance	- +	<1pF

## Mechanical Specifications

Minimum operating temperature		-20°C
Maximum operating temperature		40°C
Minimum operating humidity		5%
Maximum operating humidity		95%
Mounting method		M20
Environmental rating		IP67
Enclosure material		Stainless steel
Terminal type		Flying lead
Earthing		90V isolation
Length		53mm
Width		24mm
Height		27mm

## Other Specifications

Product Code  IS-SLT3-36-M20

## Shipping Specifications

Weight		145g
Customs tariff		85363000, 85363010