

# SSP1-20-50-275

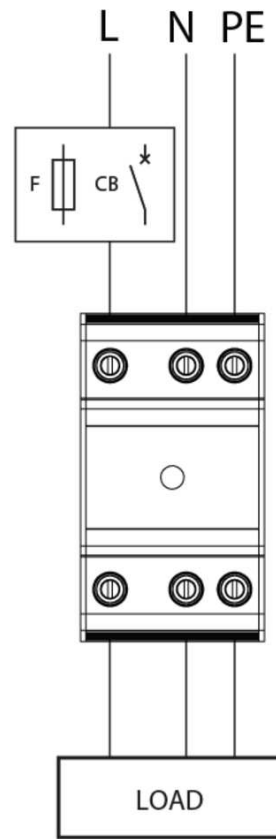

## Installation



## Terminal Information

Terminal Type	
min Capacity	2.5 mm <sup>2</sup>
max Capacity	16 mm <sup>2</sup>
Torque	2 Nm
Wire Stripping Length	12mm

## Dimensional Diagram

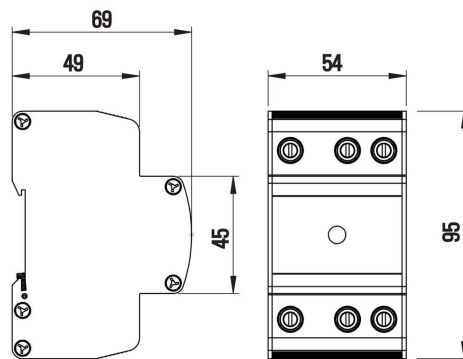

## Mounting

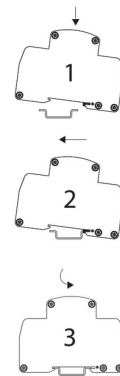

### Electrical Specifications

Connection type		Series
Modes of protection		L-N, L-PE, N-PE
Number of ports		2
Location		Indoor
Nominal voltage	U <sub>0</sub>	230VAC
Short circuit withstand level	I <sub>SSCR</sub>	25kA
Maximum backup fuse		20A
Earth leakage current	I <sub>PE</sub>	<10μA

### Mechanical Specifications

Minimum operating temperature		-40°C
Maximum operating temperature		70°C
Minimum operating humidity		5%
Maximum operating humidity		95%
Mounting method		TS35 DIN Rail
Environmental rating		IP20