

Product No: 3GAA181410-HDK**ABB IE3 ALUMINUM MOTOR 2P 22KW 400VD FOOT/BIG FLANGE
MOUNT B35 IP55 3GAA181410-HDK****General Information**

Brand	ABB
Product Type	Process Performance Motors

Technical Attributes

Efficiency	92.70%
Net Weight (kg)	176
Rated Power (kW)	22
Rated Voltage (V)	690Y/415D

Dimensions

Dimensions (mm)	341W x 405H x 726D
-----------------	--------------------

Protection & Standards

Degree of Protection	IP55
----------------------	------

Resources

Product catalogue (Flipbook)	Download from here
------------------------------	------------------------------------



TECHNICAL DRAWING

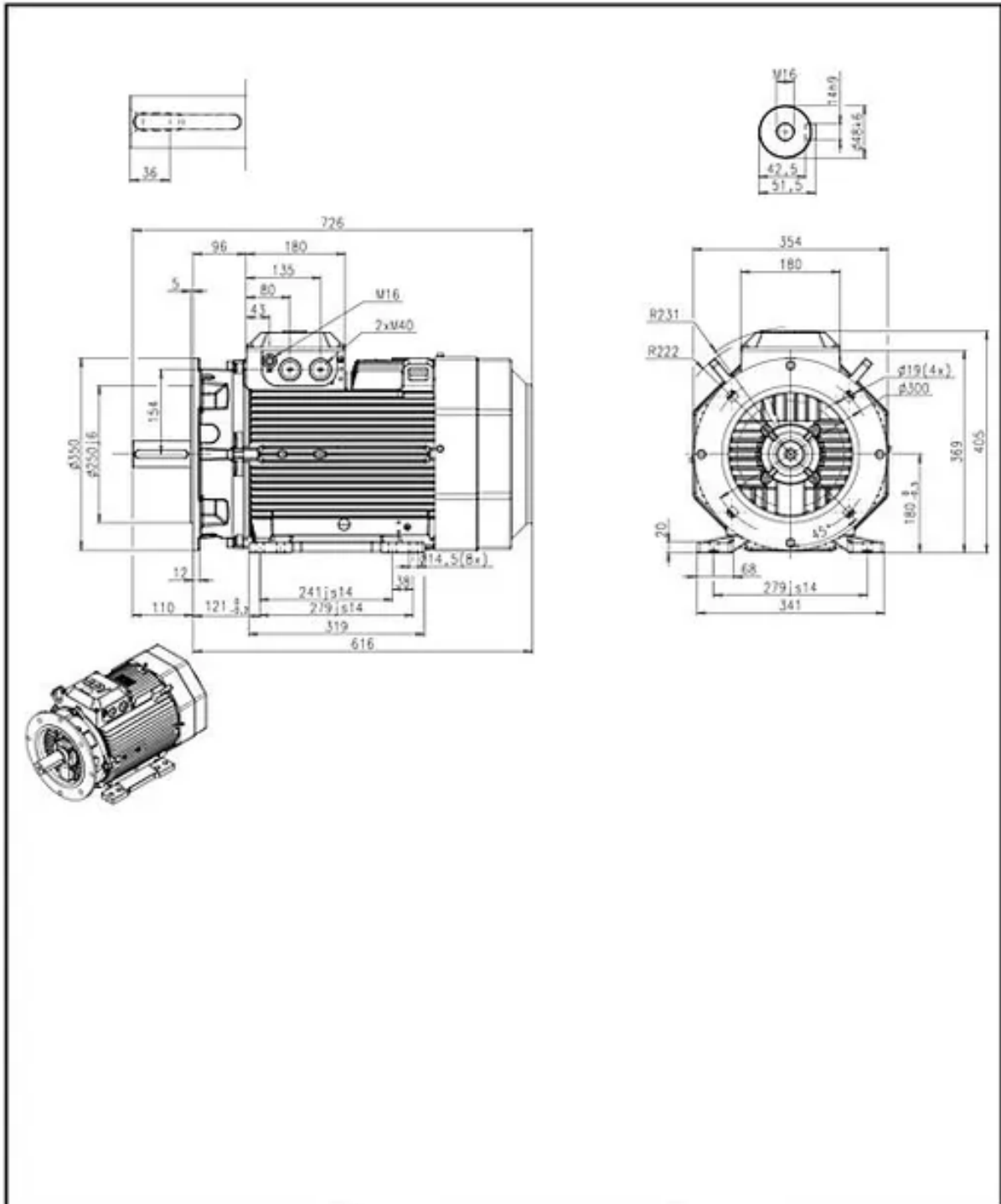

Motor Dimension Print	Motor Type: M3AA 180 IM 2001	Document No: 3GZV 102 027-C A1.5108
Description: Three phase motor,		
Unit: ABB AB, LV Motors, Sweden.	Issued by: B Abujheisha	Replaces:
Date: 2012-09-29	Approved by: N Jonsson	Replaced by:
Customer Reference:		