

NSP3-40-320-N



NSP Surge Diverter

The Novaris NSP Surge Diverter range is a type 2 SPD and is designed for low voltage power supply system protection at the boundaries between lightning protection zone 1-2.

KEMA Certified

The NSP range is certified as per IEC 61643-11, Class II 40kA.

Pluggable Plastic Enclosure

The pluggable design allows for easy replacement of the modules. Each module is made from thermoplastic extinguishing degree UL94 V-0.

Display and Alarm

The NSP range features a fault indication window, green for good and red for replace there is also a remote alarm contact available.

Wiring

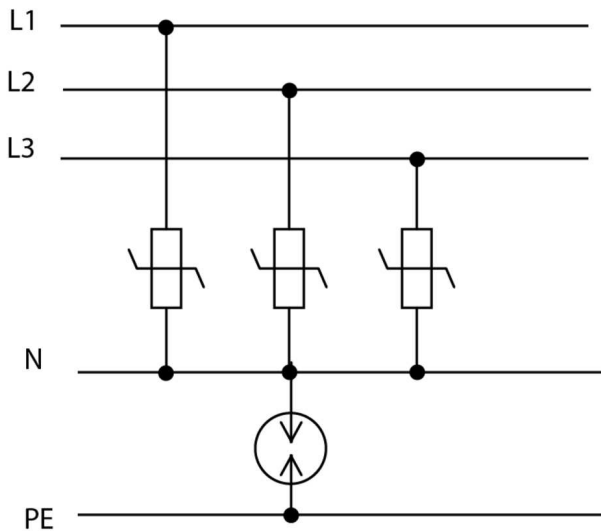

Dimensions

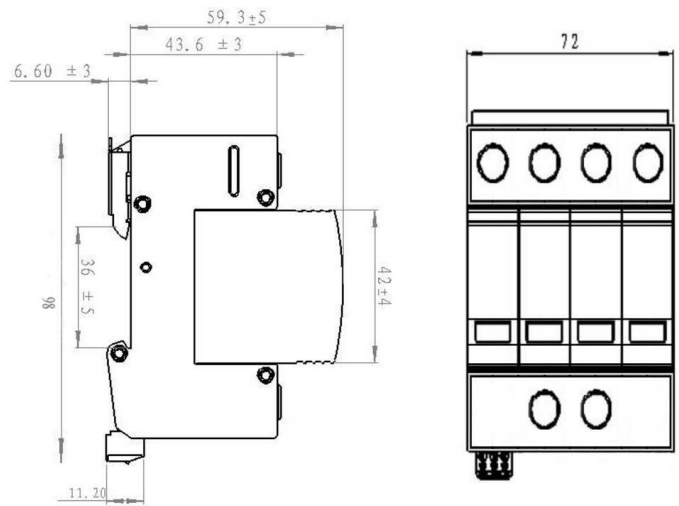





Standards

IEC 61643-11:2011
 UL 1449 3rd edition
 IEEE 62.41.2:2002

SPD connected to low-voltage power systems - Type 2
 Low voltage SPD - Type 2
 Low voltage SPD - Cat B

Electrical Specifications

Connection type		Shunt
Modes of protection		L-N, N-PE
Number of ports		1
Number of phases		3
Location		Indoor
Nominal voltage	U_0	230VAC
Short circuit withstand level	I_{SSCR}	25kA
Maximum backup fuse		125A
Recommended SCB		SCB1-3-80



Electrical (L-N) Specifications

Maximum continuous voltage AC	U_c	320VAC
Maximum discharge current (8/20 μ s)	I_{max}	40kA
Nominal discharge current (8/20 μ s)	I_n	20kA
Lightning impulse current (10/350 μ s)	I_{imp}	4kA
Voltage protection level (In)	U_p	<1500V
Response time	t_A	<25ns











Electrical (N-PE) Specifications

Maximum continuous voltage	U_c	255VAC
Maximum discharge current (8/20 μ s)	I_{max}	40kA
Nominal discharge current (8/20 μ s)	I_n	20kA
Voltage protection level (1kV/ μ s)	U_p	<1500V
Response time	t_A	<100ns
Follow current interrupt rating	I_{fi}	100A

Indication Specifications

Display		Thermal failure green normal red failure
Alarm		Thermal failure

Mechanical Specifications

Minimum operating temperature		-40°C
Maximum operating temperature		80°C
Minimum operating humidity		5%
Maximum operating humidity		95%
Mounting method		TS35 DIN Rail
Environmental rating		IP20
Terminal capacity - power		35mm ²
Terminal capacity - alarms		1.5mm ²
Length		98mm
Width		72mm
Height		65mm

Other Specifications

Product Code  NSP3-40-320-N

Shipping Specifications

Weight  200g