

SDD3-50-275

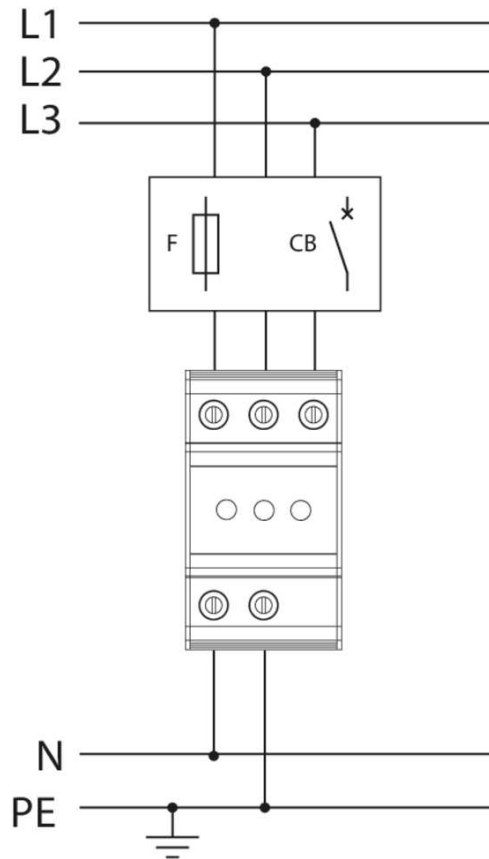

Installation



Terminal Information

Terminal Type	
min Capacity	2.5 mm ²
max Capacity	16 mm ²
Torque	2 Nm
Wire Striping Length	12mm

Dimensional Diagram

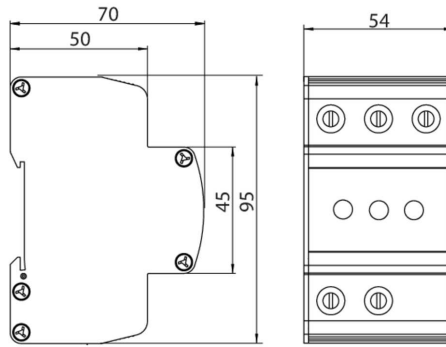

Mounting

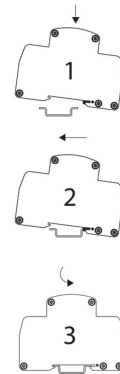

Electrical Specifications

Connection type		Shunt
Modes of protection		L-N, L-PE, N-PE
Number of ports		1
Location		Indoor
Nominal voltage	U_0	230VAC
Short circuit withstand level	I_{SSCR}	25kA
Maximum backup fuse		32A
Recommended SCB		SCB1-3-80
Earth leakage current	I_{PE}	<10μA

Mechanical Specifications

Minimum operating temperature		-40°C
Maximum operating temperature		70°C
Minimum operating humidity		5%
Maximum operating humidity		95%
Mounting method		TS35 DIN Rail
Environmental rating		IP20