

CADIZ  
19903

**ANETA**  
LIGHTING  
LIGHTS FOR HOME AND WORK SINCE 1947

SE: Utför monteringen på en matta eller annat mjukt underlag, för att undvika att lacken repas.

NO: Utfør monteringen på et teppe eller annet mykt underlag for å unngå riper i lakken.

FI: Kasaa valaisin pehmeällä alustalla jotta valaisimen pinta ei naarmuunnu.

EN: Do the assembly on a carpet or other soft surface, to avoid scratching the varnish.

[www.aneta.se](http://www.aneta.se)

[www.aneta.no](http://www.aneta.no)

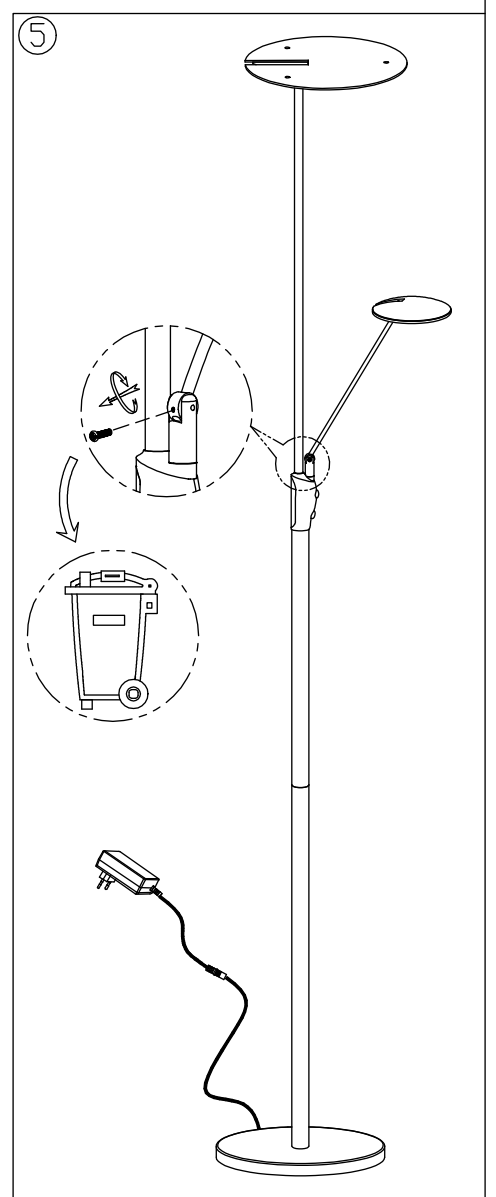
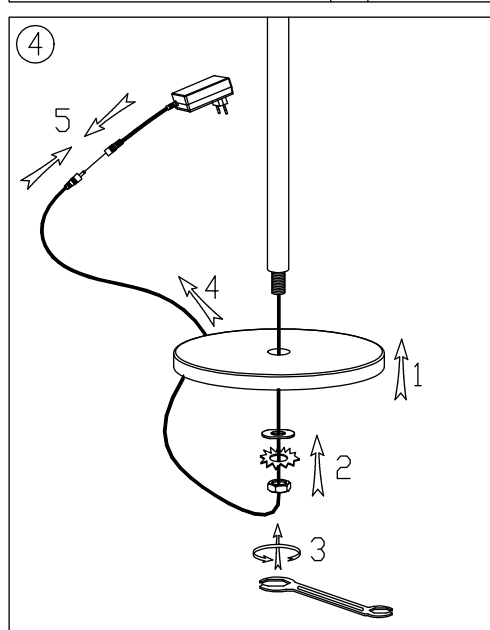
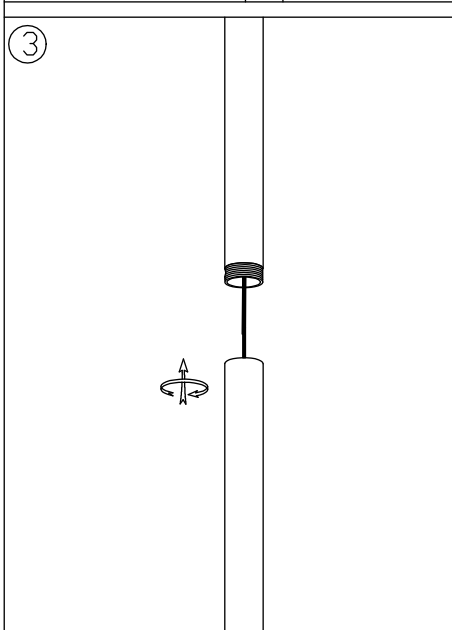
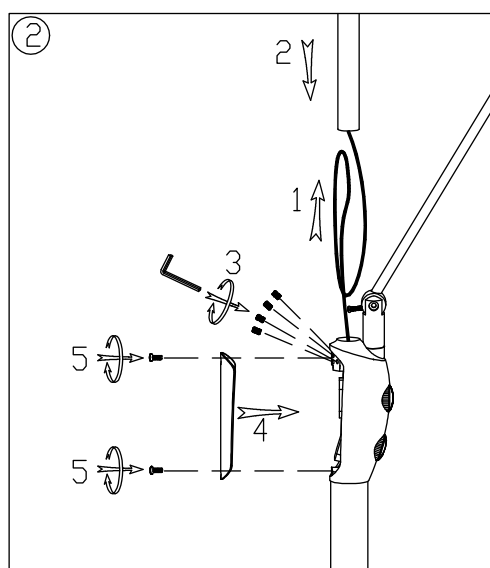
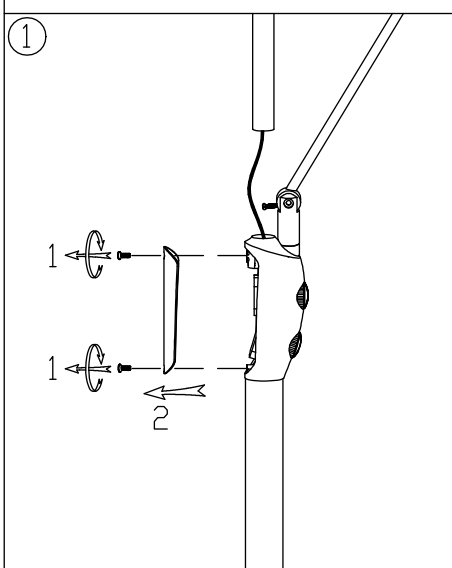
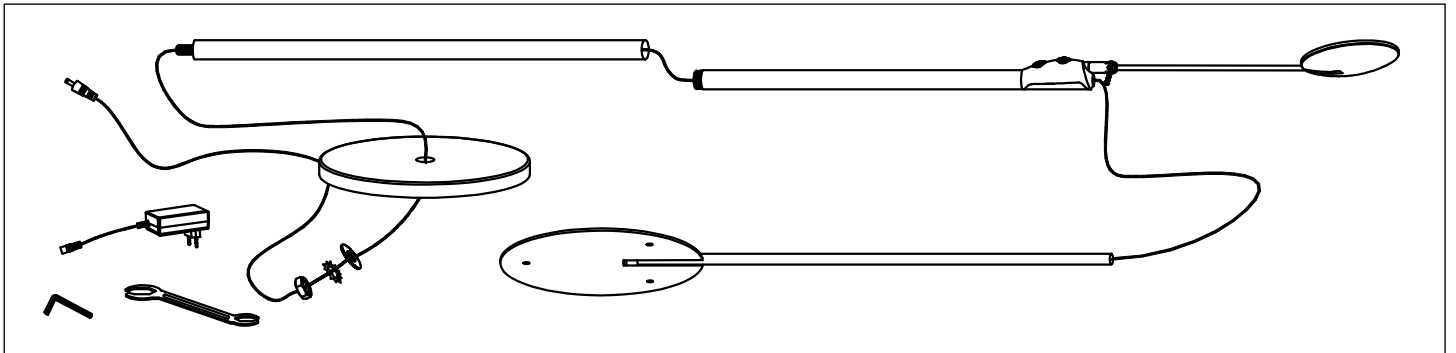

CADIZ  
19903

**ANETA**  
**LIGHTING**  
LIGHTS FOR HOME AND WORK SINCE 1947

SE: Denna produkt innehåller två ljuskällor med, båda med energieffektivitetsklass F. LED-ljuskällorna är utbytbara som reservdel.

NO: Dette produktet inneholder to lyskilder, begge med energieffektivitetsklasse F. LED-lyskildene kan skiftes som reservdel.

FI: Tämä tuote sisältää kaksi valonlähdettä, molempien energiatehokkuusluokka on F. LED valolähde vaihdetta vissa, löytyy varaosana.

EN: This product contains two light sources, both of energy efficiency class F. The LED light sources are replaceable as a spare part.

Light Source data:..... Upper lamp..... Reading lamp

Lighting technology used: ..... LED..... LED  
Mains or non-mains: ..... non-mains..... non-mains  
Directional or non-directional: ..... non-directional..... non-directional  
Connected L.S.: ..... no..... no  
Color-tuneable: ..... no..... no  
Envelope: ..... no..... no  
High luminance: ..... no..... no  
Anti-glare shield: ..... no..... no  
Dimmable: ..... yes..... yes  
Energy consumption in on-mode: 28 kWh / 1000 h..... 5 kWh/1000h  
Energy efficiency class (A-G): ..... F..... F  
Useful luminous flux:..... 3100 lm \*..... 500 lm \*  
CCT colour temperature:..... 3000 K ..... 3000 K  
On-mode power: ..... 28 W..... 5W  
Stand-by power: ..... N/A..... N/A  
Networked standby power: ..... N/A ..... N/A  
CRI: ..... >80 ..... >80  
R9 color rendering index: ..... 1 ..... 1  
Chromaticity coordinates: ..... x:0.440, y:0.404..... x:0.440, y:0.404  
Lifetime L<sub>70</sub>/B<sub>50</sub>: ..... 50 000 hours..... 50 000 hours  
Lumen maintenance factor: ..... 0,96 ..... 0,96  
Survival factor: ..... 0,9 ..... 0,9  
Power supply input: ..... 24VDC..... 24VDC

\* The luminous flux stated here is the value for the light source itself in accordance with Regulation (EU) 2019/2015. On the box the luminous flux for the lighting fitting is stated, where the light is partly absorbed by glass/glare shield/shade and parts of the fitting, why it is lower than for the light source.

SE: Rengöring: Torkas med torr trasa.

Kabeln kan ej bytas. Om kabeln på lampn blir skadad skall lampen lämnas till återvinningscentral.

NO: Rengjøring: Tørkes av med tørr klut.

Ledningen kan ikke skiftes. Hvis ledningen til lampen blir skadet må lampen leveres til gjenvinningsstasjon.

FI: Puhdistus: Pyyhi kuivalla liinalla.

Johtoa ei voi vaihtaa. Jos johto on vahingoittunut tuhoa valaisin ja toimita valaisin kierrätyspisteeseen.

EN: Cleaning: Wipe with a dry cloth.

The cable of this luminaire can not be replaced. If the cord is damaged the luminaire shall be left to a recycling station.