

SANDWICH PANEL SCREW

SELF DRILLING SCREW FOR FASTENING OF SANDWICH PANELS TO STEEL



- #2+ drill point for one step installation with no need for predrilling
- Tall head for easy and stable mounting
- Surface treated with ZYTEC™ M for good corrosion resistance
- The large thread and cone below the head as well as the washer with bonded EPDM ensures a better load distribution and sealing abilities
- Available in more than 500 colours (QUALICOAT certified powder)



European Technical
Assessment ETA-20/0709

Hex head

Corrosion
category C3

Hardened
steel

PRODUCT RANGE

MG/PG	Item no.	Item name	Washer [mm]	Thread [mm]	Length L [mm]	Panel thickness [mm]	Drill capacity [mm]	Head [mm]	Unit [pcs]
06 1005	13612	HWH 5.5/6.3 X 60 #2+ "A" HX8 ALU-19B	ALU Ø19	Ø5.5	60	18 - 40	1.5 - 4.0	Ø10.0 HEX 8.0	100
	13613	HWH 5.5/6.3 X 80 #2+ "A" HX8 ALU-19B			80	18 - 60			
	13614	HWH 5.5/6.3 X 100 #2+ "A" HX8 ALU-19B			100	18 - 80			
	13616	HWH 5.5/6.3 X 145 #2+ "A" HX8 ALU-19B			145	63 - 125			
	13617	HWH 5.5/6.3 X 180 #2+ "A" HX8 ALU-19B			180	98 - 160			
	13618	HWH 5.5/6.3 X 230 #2+ "A" HX8 ALU-19B			230	148 - 210			
	13619	HWH 5.5/6.3 X 280 #2+ "A" HX8 ALU-19B			280	198 - 260			
	13620	HWH 5.5/6.3 X 330 #2+ "A" HX8 ALU-19B			330	248 - 310			

TYPICAL APPLICATION

- Fastening of sandwich panels to steel

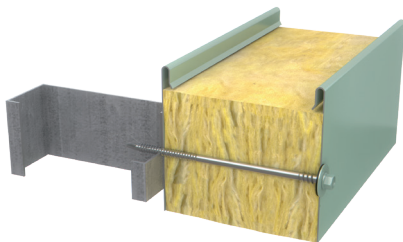

INSTALLATION INSTRUCTIONS

For optimal performance it is important to follow the installation instructions. An incorrect installation may lead to decreased sealing abilities and/or load bearing capacity.

For optimal drill performance, it is recommended that the rotational speed is 1600 - 2200 RPM.

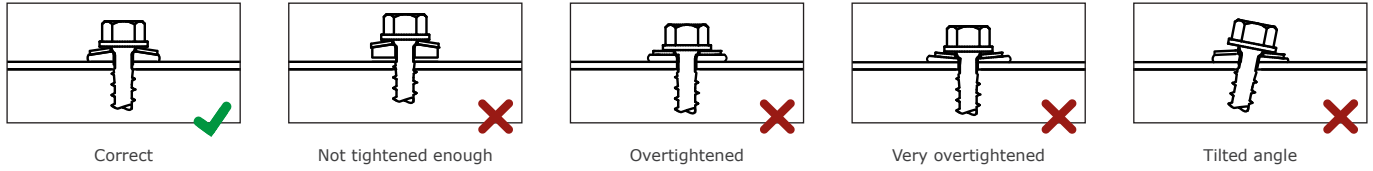

GOOD TO KNOW

Sandwich panels are often constructed from an insulating layer with glued steel sheeting with a thickness of 0.6 mm. Practical tests show that deformation of the steel plate on the outside of the sandwich panel occurs by a force of approximately 1.0 kN when using a screw with Ø19 mm washer with EPDM. This should be taken into consideration during the calculation of a given structure assembly.

TECHNICAL DATA

Outer diameter, D_1/D_2	[mm]	Ø5.5/6.3
Inner diameter, d	[mm]	Ø4.1
Head diameter, d_h	[mm]	Ø10.0
Washer diameter, d_w	[mm]	Ø19.0
Drill point diameter, d_p	[mm]	Ø4.5
Drill point length, l_p	[mm]	8.0
Pitch, P	[mm]	1.8
Drive type, R	[-]	HEX 8.0

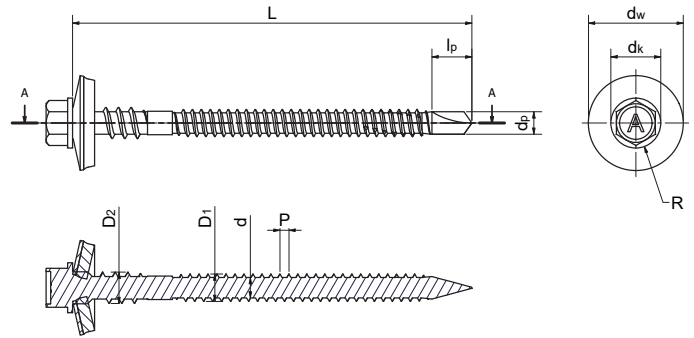

DESIGN RESISTANCE

The design resistance of the screw is determined in accordance with european technical assessment ETA-20/0709.

The resistance when loaded in tension, N_{Rd} , appears from the table on the right and is the minimum value of the pull-out resistance of the supporting object, the pull-through resistance of the outermost steel sheet of the sandwich panel, and the tension resistance of the screw.

The resistance when loaded in shear, V_{Rd} , appears from the table on the right and is the minimum value of the bearing resistance of the supporting object and the innermost steel sheet of the sandwich panel, and the shear resistance of the screw.

The theoretical values must be considered indicative since the conditions at the construction site may vary. Practical tests of the specific application are recommended for verification of the listed values.

Assumptions:

Fixed object: Sandwich panel

Steel sheets: S280GD - EN 10346

Supporting object: Steel S280GD - EN 10346

$t_{t,t}$ = Thickness of the outermost steel sheet of the sandwich panel [mm]

$t_{t,f}$ = Thickness of the innermost steel sheet of the sandwich panel [mm]

t_{II} = Thickness of the supporting object [mm]

All resistances are stated in kN (1 kN \approx 100 kg)

Safety factor: $\gamma_M = 1.35$

MG/PG: 06 1005 HWH 5.5/6.3 X L #2+ "A" HX8 ALU-19B

Design resistance when loaded in tension, N_{Rd} [kN]						
$t_{t,t} \backslash t_{II}$	1.50	2.00	2.50	3.00	3.50	4.00
0.40	1.07	1.07	1.07	1.07	1.07	1.07
0.50	1.33	1.33	1.33	1.33	1.33	1.33
0.55	1.61	1.66	1.66	1.66	1.66	1.66
0.63	1.61	2.20	2.20	2.20	2.20	2.20
0.75	1.61	2.37	3.00	3.00	3.00	3.00
0.88	1.61	2.37	3.27	3.27	3.27	3.27
1.00	1.61	2.37	3.39	3.53	3.53	3.53

Design resistance when loaded in shear, V_{Rd} [kN]						
$t_{t,t} \backslash t_{II}$	1.50	2.00	2.50	3.00	3.50	4.00
0.40	0.57	0.57	0.57	0.57	0.57	0.57
0.50	0.83	0.83	0.83	0.83	0.83	0.83
0.55	1.04	1.04	1.04	1.04	1.04	1.04
0.63	1.38	1.38	1.38	1.38	1.38	1.38
0.75	1.87	1.87	1.87	1.87	1.87	1.87
0.88	2.08	2.08	2.08	2.08	2.08	2.08
1.00	2.27	2.27	2.27	2.27	2.27	2.27

DECLARATION OF PERFORMANCE

In compliance with 'REGULATION (EU) No 305/2011 of the European Parliament and of the Council of 9 March 2011 laying down harmonised conditions for the marketing of construction products' (the Construction Products Regulation or CPR), it is stated that the performance of the construction product identified below is in conformity with the declared performance.

Product identification

MG:06 PG:1005 | HWH 5.5/6.3 X L #2+ "A" HX8 ALU-19B

(Main Group # Product Group # | Item name)

The screws mentioned above are packed in branded cartons clearly marked with CE according to ETA-20/0709. For specification of the intended use and declared performance of the product please refer to the technical data sheet.

Placed on the market by:

ASTON SWEDEN AB

Hangarvägen 23

SE-691 35 Karlskoga, Sweden

(Name / address)

European Assessment Document: EAD 330047-01-0602

European Technical Assessment: ETA-20/0709

Technical Assessment Body: ETA Danmark

Notified Body no.: 0769

System of AVCP: 2+

This declaration of performance is issued under the sole responsibility of the manufacturer identified above.



Morten Johansen
M.Sc., Engineering



SWEDEN

Company stamp
RED HORSE | dissing as

2022-08-01

Date of issue