

Halton CHH – Chilled beam

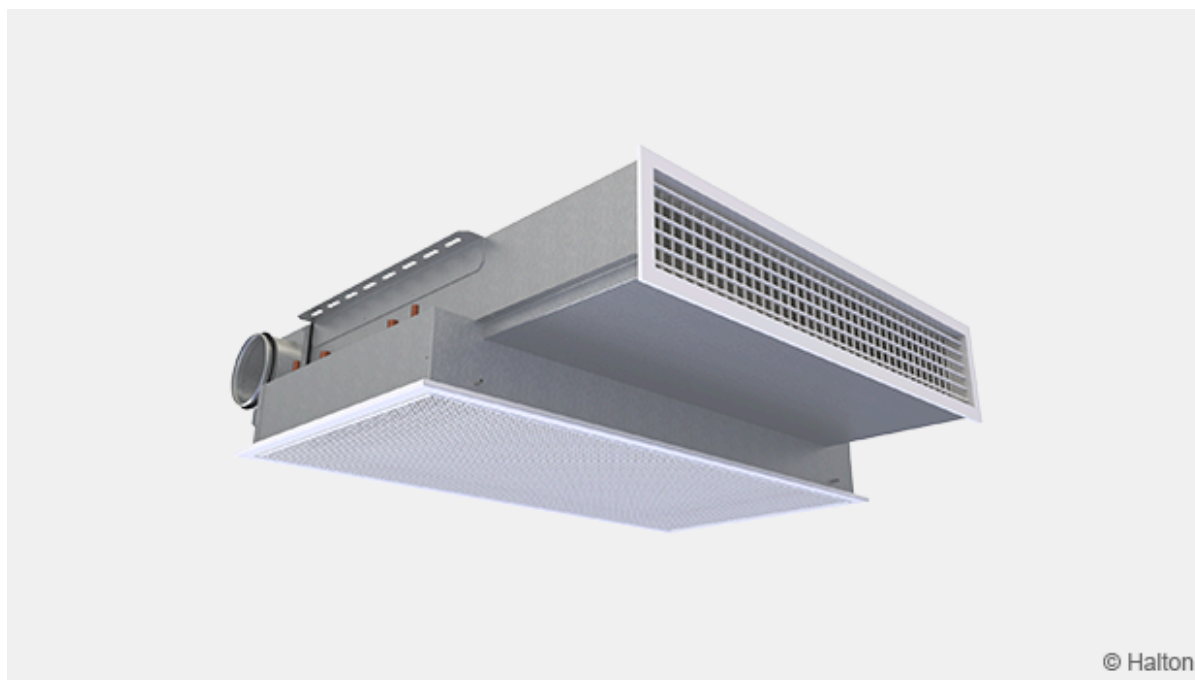

Overview

- Combined cooling, heating, and supply air unit for suspended ceiling / bulkhead installation
- Enhanced life-cycle performance:
 - Energy-efficient solution with low air and water flow rates in both cooling and heating modes.
 - Suitable system for use with free energy sources and heat pumps.
 - Low-cost maintenance due to simple and hygienic principle of operation. Operates as a non-condensating dry system with minimal use of mechanical parts: no fan, no mechanical filters, no condensation tray, and no drainage tubing
- Efficient ordering and installation:
 - Ability to change the position of the primary air inlet spigot and waterside pipe connections on-site to match the installation conditions.

Product options and accessories

- Model with combined cooling and heating coil
- Option for different supply air grilles
- Integrated control valves and actuators

Halton chilled beams are certified by Eurovent Certita.

[Link to Certificate](#)



Material

| Part | Material | Finishing | Note |
|----------------------------|------------------------------|---|--|
| Return air grille | Pre-painted galvanised steel | Polyester-painted White (RAL 9003 or RAL 9010, 20% gloss) | Special colours available Polyester-epoxy-painted |
| Supply air grille G = A | Aluminium | Polyester-epoxy-painted White (RAL 9003 or RAL 9010, 20% gloss) | Special colours available Polyester-epoxy-painted |
| Supply air grille G = B | Steel | Polyester-epoxy-painted White (RAL 9003 or RAL 9010, 20% gloss) | Special colours available Polyester-epoxy-painted |
| Casing | Galvanised steel | – | – |
| Supply air plenum | Galvanised steel | – | – |
| Brackets | Galvanised steel | – | – |
| Coil pipes | Copper | – | – |
| Coil fins | Aluminium | – | – |

Cooling / heating water pipe connections are Cu15/Cu12 with wall thickness of 0.9-1.0 mm, fulfilling European standard EN 1057:1996. The maximum operating pressure for chilled/hot water pipework is 1.0 MPa. The supply air duct connection diameter is 125 mm.

Accessories

| Accessory model | Code | Description | Note |
|-----------------------------------|-----------------------|---|---|
| Supply air grille | G = A | Aluminium grille with 7 fixed horizontal front vanes for horizontal air supply. Fixed front vanes, stable throw pattern with vertical 15° deflection. Aluminium construction with elegant look. | As standard, supply and return air grilles are supplied in the same colour. Grilles also can be delivered in different colours on request. If another grille is needed for the space, Halton recommends to use Halton AWE that has similar outlook. |
| Supply air grille | G = B | Steel grille with 9 horizontal front vanes for horizontal air supply. Adjustable horizontal front vanes max 15°. Robust steel construction. | As standard, supply and return air grilles are supplied in the same colour. Grilles also can be delivered in different colours on request. If another grille is needed for the space, Halton recommends to use Halton WTS that has similar outlook. |
| Combined cooling and heating coil | TC = H | H = coil with hot water circulation. | Copper water pipe connections are Ø 15 mm (cooling) and Ø 10 mm (heating) |
| Control valve | CV = see product code | Valves with adjustable kvs value (Danfoss RA-C dn15) or with max flow limit function (Danfoss AB-QM dn 10 in heating and Danfoss AB-QM dn 15 in cooling). | Delivered factory fitted or loose. If control valves are factory fitted in the factory, the location of the pipe connections cannot be changed on the site. |
| Valve actuator | VM = see product code | Thermal on/off actuators (230 VAC NC or 24 VAC NC) for both valve types. | Delivered factory fitted or loose. Cable length 1.2m. |



Fig.1. Aluminium air supply air grille

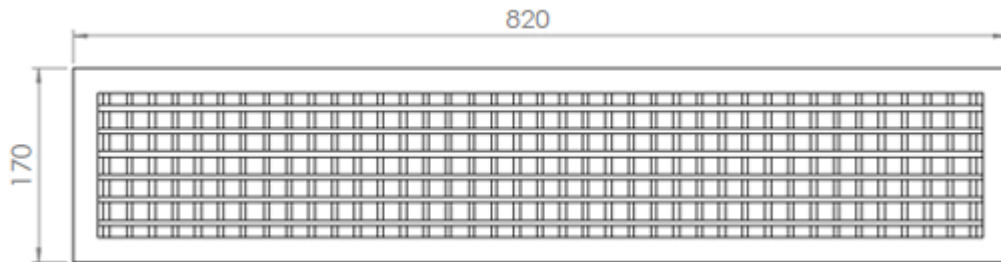
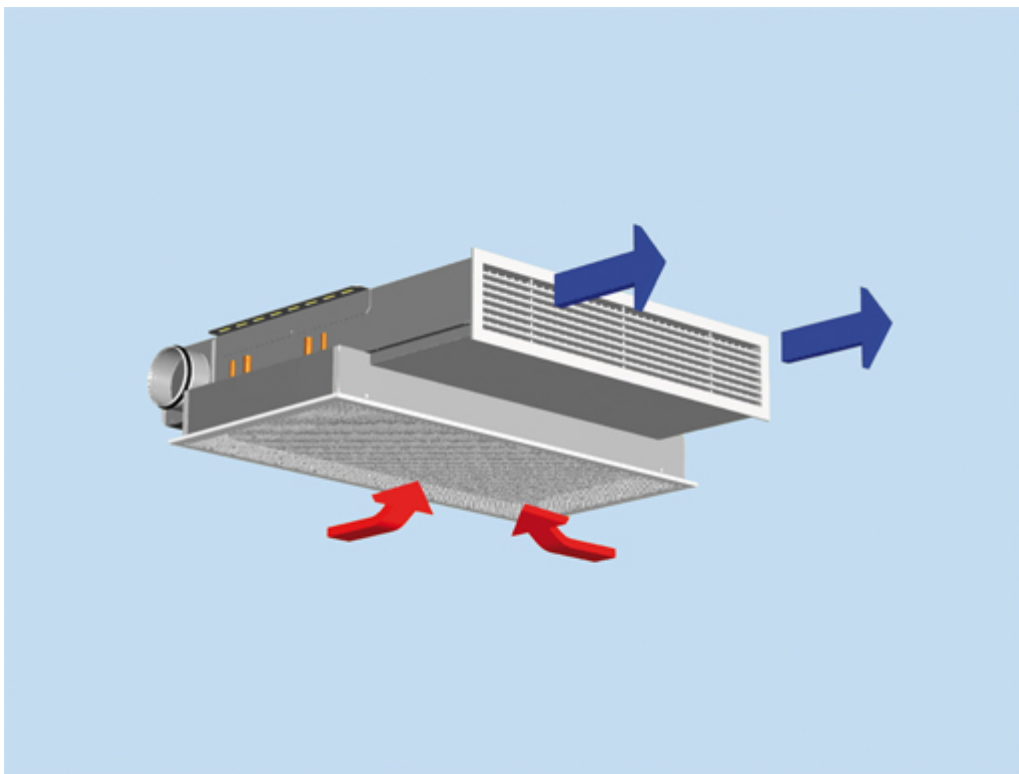

Fig.2. Steel air supply air grille

Function



The Halton CHH unit is an active chilled beam for bulkhead installation.

The primary supply air enters the plenum of the active chilled beam, from where it is diffused into the room through nozzles and a supply grille on the front side of the beam. The supply air nozzle jets efficiently induce ambient room air through the lower return air grille and the heat exchanger, where it is either cooled or heated. The combined air jet is directed along the ceiling surface.

Three different nozzle sizes are available to enable various supply air flow rates. The nozzle plates are inter-changeable to account for layout or room changes.

Waterside cooling and heating capacity control

The chilled beam can be equipped in the factory with either a standard control valve or a combination control valve.

Controls may include either a standard control valve or a combination control valve. Both control valves are operated with a thermal actuator, and the water flow rate of the control valve is based on room air temperature. The standard control valve has an adjustable kvs value. The combination control valve has an adjustable nominal water flow rate and there is a pressure difference measurement across the control valve in order to ensure that enough pressure difference (min.: 16 kPa) is available to achieve the adjusted water flow rate and the automatic balancing in use. See Document-section for more information.

Installation

The Halton CHH unit is suitable for bulkhead and suspended ceiling installation. The chilled beam ceiling brackets can be fixed directly to the ceiling surface or suspended using threaded drop rods (8 mm). The recommended maximum distance of the supply air grille from the ceiling is 200 mm. The return air grille has a 40-mm telescopic connection and the supply air grille a 200-mm telescopic connection.

Install the main pipelines of the cooling and heating water loops above the level of the chilled beams to allow venting of the pipework.

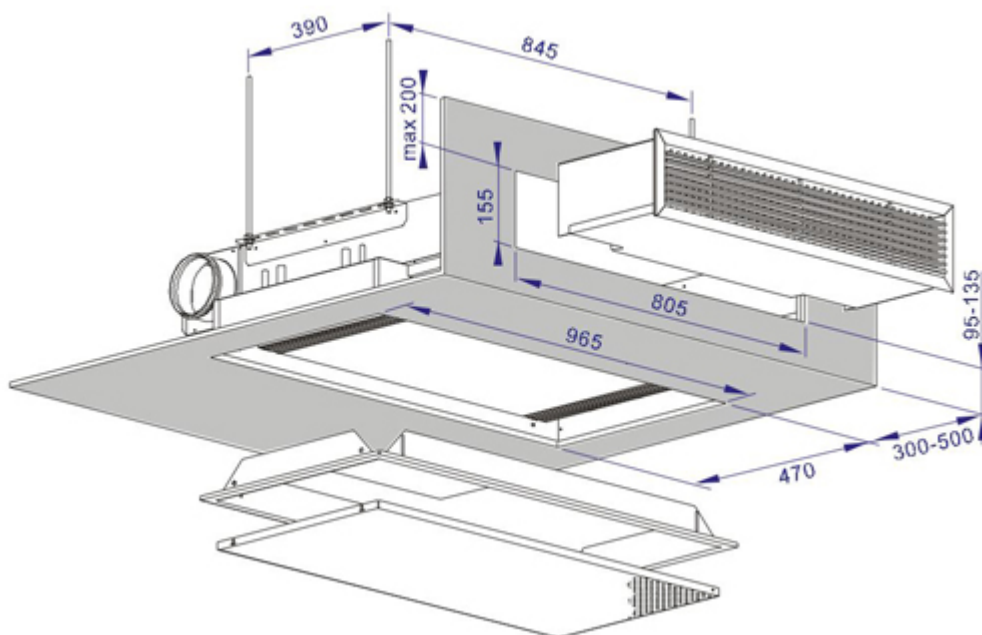

If unit is delivered with factory fitted valves, there must be c. 80mm space above unit.

Adjustment

Cooling

The recommended cooling water mass flow rate is 0.02 0.10 kg/s, resulting in a temperature rise of 1 4 °C in the heat exchanger. To avoid condensation, the recommended inlet water temperature of the heat exchanger is 14 16 °C.

Heating

The recommended heating water mass flow rate is 0.01 0.04 kg/s, resulting in a temperature drop of 5 15 °C in the heat exchanger. The recommended temperature of the inlet water for the heat exchanger is 35 45 °C.

Balancing and control of water flow rates

Balance the water flow rates of the chilled beam with the standard control valve by selecting the design kvs value in the valve body. When using an automatically balancing combination valve, set the design water flow rate in the valve body and verify the pressure difference (min.: 16 kPa) across the valve. Regulating the water mass flow rate controls the cooling and heating capacity of the chilled beam.

Adjustment of supply airflow rate

Each chilled beam is equipped with a measurement tap for static pressure measurement, which enables fast and accurate measurement of the supply air flow rate through the beam.

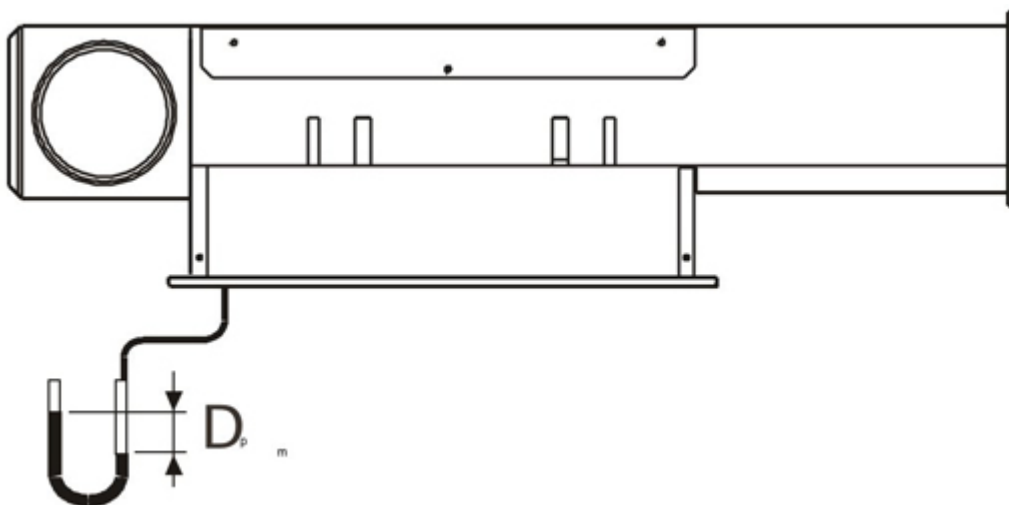

The air flow rate is calculated using the formula below.

| Nozzle | k |
|--------|------|
| A | 2.11 |
| B | 3.03 |
| C | 4.15 |

$$q_v = k * \sqrt{\Delta p_m}$$

Servicing

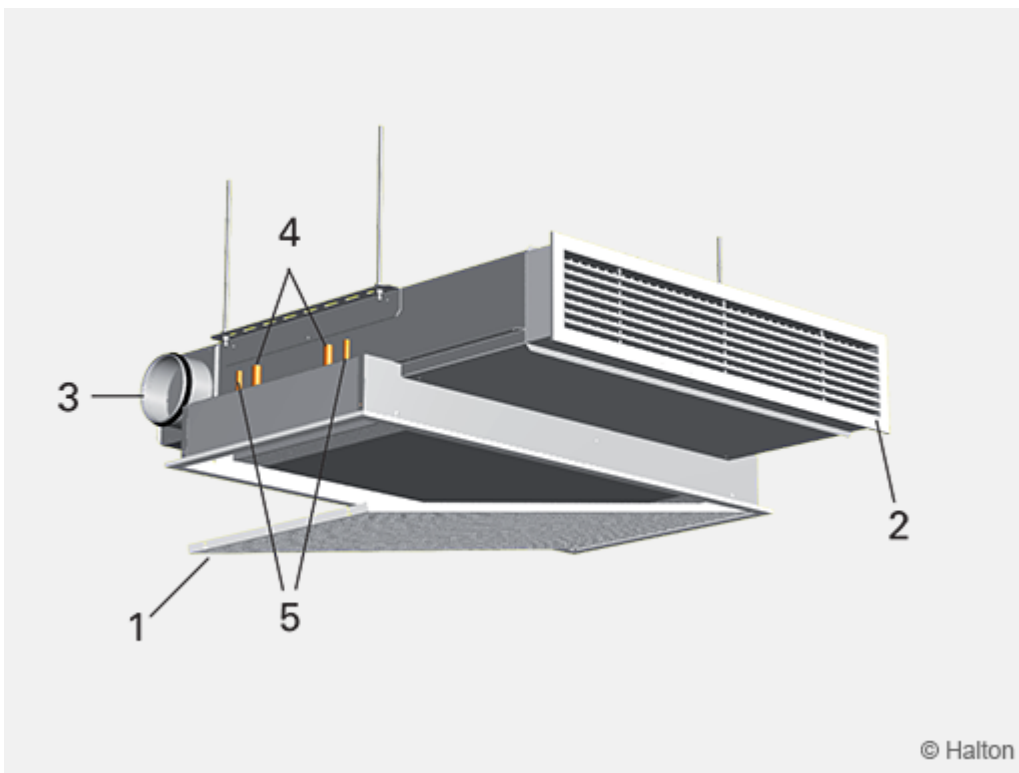

Key

1. Return air grille
2. Supply air grille
3. Supply air connection
4. Chilled water pipe connections
5. Heating water pipe connections

Open the return air grille of the chilled beam. Clean the finned coils of the heat exchanger using a vacuum cleaner, taking care not to damage the finned coils. Clean the return and supply air grilles with a damp cloth.

Check at regular intervals that the actuators and water flow control valves are working.

Specification

The Halton CHH unit is an active chilled beam for bulkhead and enclosed installation with return and supply air grilles.

The return air and supply air grilles are openable and removable for maintenance. The return air grille has a 40-mm telescopic connection and the supply air grille a 200-mm telescopic connection. The active chilled beam is 1000 mm wide, 925 mm in length, and 250 mm high, with an inlet duct diameter of 125 mm.

The inlet duct connection is changeable and able to be located at the right, left, or middle of the supply air plenum.

The heat exchanger of the beam is oriented such that the water connections may be located on either the right or left side of the beam.

All pipes are manufactured from copper, connection pipes with a wall thickness of 0.9-1.0 mm. The fins of the heat exchanger are manufactured from aluminium. The heat exchanger is factory pressure-tested. The maximum operating pressure of pipework is 1.0 MPa.

Each active chilled beam is protected by a removable plastic coating and individually packed in a plastic bag. Duct connection and pipe ends are sealed during transit.

Each chilled beam is identifiable by a serial number printed on a label attached to the active chilled beam.

Order code

CHH/S-E-K-G; TC-CO-CV-VM-ZT

S = Nozzle type

- A Nozzle 5
- B Nozzle 6
- C Nozzle 7

E = Location of supply air connection

- R Right
- L Left
- M Middle

K = Location of pipe connections

- R Right
- L Left

G = Type of air supply air grille

- A Aluminium
- B Steel

Other options and accessories

TC = Cooling / heating functions (coil type)

- C Cooling
- H Cooling and heating

CO = Colour of grilles

- SW Signal white (RAL9003)
- W Pure white (RAL 9010)
- X Special colour (RALxxxx)

CV = Control valves

- N Not assigned
- A1 Adjustable kvs (Danfoss RA-C dn15); factory fitted
- A2 Adjustable kvs (Danfoss RA-C dn15); loose
- A3 Max flow limit (Danfoss AB-QM dn 10 (heating) and dn15 (cooling)); factory fitted
- A4 Max flow limit (Danfoss AB-QM dn 10 (heating) and dn15 (cooling)); loose

VM = Valve actuator(s)

- N Not assigned
- A1 24 V
- A2 230 V

ZT = Tailored product

- N No
- Y Yes (ETO)

Code example

CHH/A-M-R-A, TC=C, CO=SW, CV=N, VM=N, ZT=N