

Wiring Diagram InoVent AHU 200-700

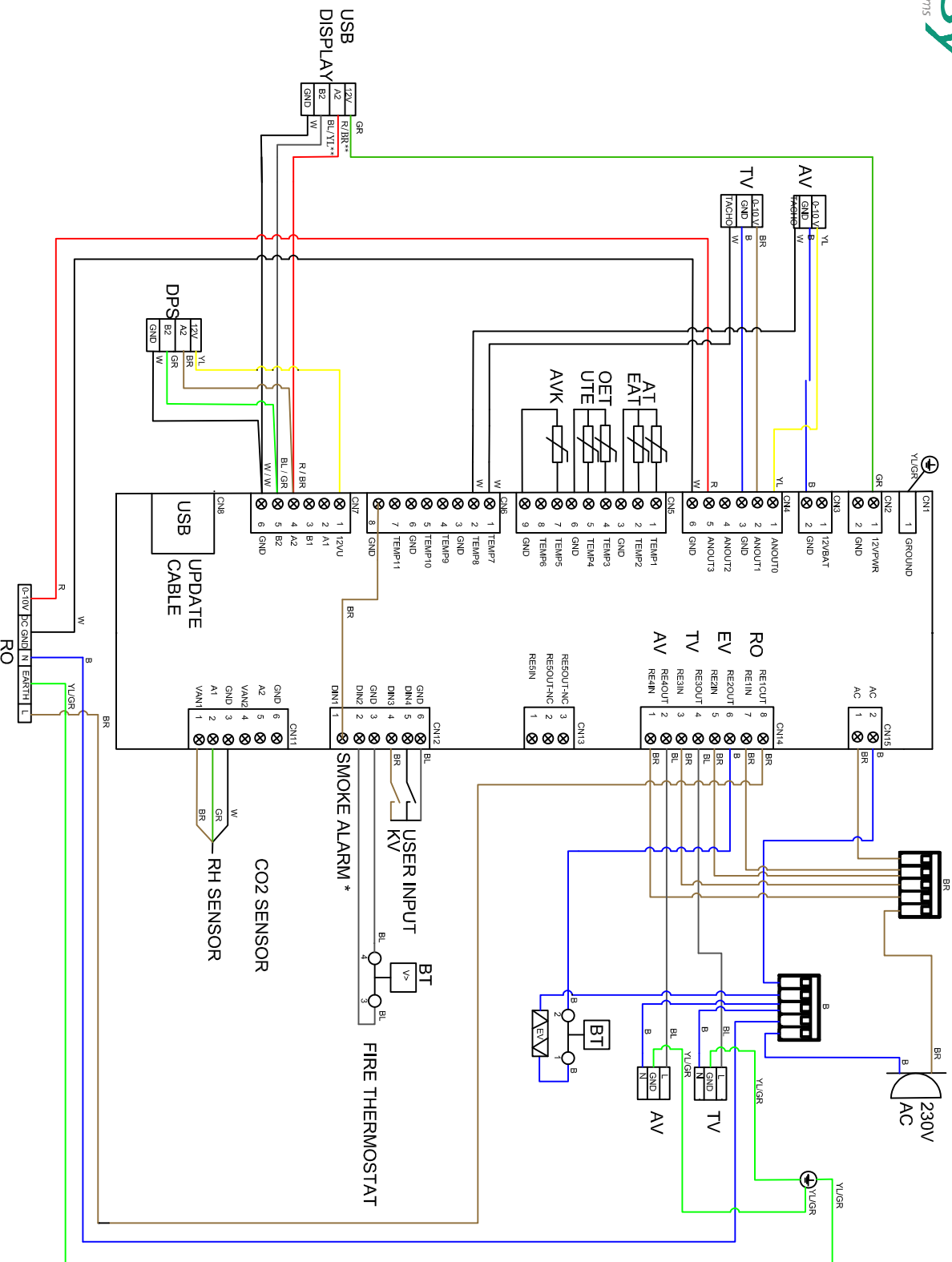

* WHEN YOU WANT TO INSTAL THE SMOKE ALARM, YOU NEED TO PULL OUT THE STRAP (CN12-1 AND CN6-8) AND PUT THE SMOKE ALARM CABLES !

** FOR CEILING MODELS , THE DISPLAY HAS 2 DIFFERENT COLORS ON THE WIRES ! **RED= BROWN AND BLACK = YELLOW**

GB WIRING DIAGRAM

W	= WHITE
BR	= BROWN
YL	= YELLOW
GR	= GREEN
YL/GR	= YELLOW/GREEN
B	= BLUE
BL	= BLACK
G	= GREY
R	= RED
AT	= OPERATIONAL TEMPERATURE SENSOR
EAT	= EXTRACT AIR SENSOR
OET	= OVERHEAT TEMPERATURE SENSOR
UTE	= FRESH AIR SENSOR / DEFROST SENSOR
AVK	= ROTOR GUARD
TV	= SUPPLY FAN
AV	= EXTRACT FAN
EV	= REHEATER BATTERY
RO	= ROTOR MOTOR
BT	= FIRE THERMOSTAT
KV	= COOKERHOOD
DPS	= DIFFERENTIAL PRESSURE SENSOR (OPTIONAL)

N KOBLINSSKJEMA

W	= HVIT
BR	= BRUN
YL	= GUL
GR	= GRØNN
YL/GR	= GUL/GRØNN
B	= BLÅ
BL	= SORT
G	= GRA
R	= RØD
AT	= ARBEIDSTEMPERATUR SENSOR
EAT	= AVTREKSTEMPERATUR SENSOR
OET	= OVERHETNINGSTEMPERATUR SENSOR
UTE	= FRISKLUFT TEMPERATUR SENSOR /
	AVRIMINGSENSOR
AVK	= ROTORVAKT
TV	= TILLUFTVIFTE
AV	= AVTREKKSIVIFTE
EV	= WITTERVARMEBATTERI
RO	= ROTOR MOTOR
BT	= BRANNTERMOSTAT
KV	= KJØKKENHETTE (TILBEHØR)
DPS	= DIFFERENSIALTRYKKSSENSOR (VALGFRI)

RO DIAGRAMA DE CABLARE

W	= ALB
BR	= MARO
YL	= GALBEN
GR	= VERDE
YL/GR	= GALBENVERDE
B	= ALBASTRU
BL	= NEGRU
G	= GRI
R	= ROSU
AT	= SENZOR AER PROASPAT
EAT	= SENZOR ASPIRARE AER VICIAT
OET	= SENZOR PENTRU SUPRAINCALZIRE
UTE	= SENZOR AER EXTERIOR
AVK	= SENZOR REFULARE AER VICIAT
TV	= MOTOR AER PROASPAT
AV	= MOTOR AER VICIAT
EV	= ELEMENT DE INCALZIRE
RO	= MOTOR SCHIMBATOR DE CALDURA
BT	= TERMOSTAT
KV	= HOTA BUCATARIE
DPS	= SENZOR DE PRESIUNE DIFERENTIAL (OPTIONAL)

IT SCHEMA ELETTRICO

W	= BIANCO
BR	= MARRONE
YL	= GIALLO
GR	= VERDE
YL/GR	= GIALLOVERDE
B	= BLU
BL	= NERO
G	= GRIGIO
R	= ROSO
AT	= SENSORE DI TEMPERATURA DI FUNZIONAMENTO
EAT	= ESTRARRE SENSORE DELL'ARIA
OET	= SENSORE DI TEMPERATURA DI SUPRISCALDAMENTO
UTE	= SENSORE ARIA FRESCA
AVK	= GUARDIA ROTOR
TV	= VENTILATORE DI MANDATA
AV	= VENTILATORE ESTRATTO
EV	= BATTERIA RISCALDATORE
RO	= MOTORE A ROTORE
BT	= TERMOSTATO ANTINCENDIO
KV	= CAPPA
DPS	= SENSORE DI PRESSIONE DIFFERENZIALE (OPZIONE)