



EDITION 2019

K-FLEX® IN CLAD SYSTEM APPLICATION MANUAL

www.kflex.com



INDEX

▶ **K-FLEX® IN CLAD SYSTEM**

General informations Pg 5

▶ **TOOLS**

The applications tools Pg 6

Application tips for K-FLEX® elastomeric material Pg 7

Application tips for K-FLEX® IN CLAD foil Pg 7

▶ **TUBES**

Insulation with K-FLEX® elastomeric sheet or tube Pg 9

Application of IN CLAD finishing foil
on tubes insulated with K-FLEX® elastomer Pg 11

The use of K-FLEX® sheet with IN CLAD finishing already applied Pg 15

Pre-cut tube with IN CLAD finishing already applied Pg 22

▶ **ELBOWS**

Insulation with K-FLEX® elastomeric elbows Pg 28

Finishing of elbows with IN CLAD sheet Pg 29

Installation of pre-shaped K-FLEX® IN CLAD elbows Pg 33

▶ **“T-PIECE”**

Finishing of “T-piece” with IN CLAD sheet Pg 36

Installation of pre-shaped K-FLEX® IN CLAD “T-piece” Pg 43

▶ **FLANGES**

Finishing of flanges with IN CLAD sheet Pg 48

Installation of pre-shaped K-FLEX® IN CLAD flanges Pg 55

▶ **VALVES**

Finishing of valves with IN CLAD sheet Pg 58

Installation of pre-shaped K-FLEX® IN CLAD valves Pg 77

▶ **REDUCERS**

Finishing of reducers with IN CLAD sheet Pg 80

▶ **SMALL AND MEDIUM TANKS**

Insulation of tanks with K-FLEX® sheet Pg 83

Finishing of tanks with IN CLAD sheet Pg 85

▶ **LARGE TANKS**

Insulation of tanks with K-FLEX® sheet Pg 90

Finishing of tanks with IN CLAD sheet Pg 92

The use of K-FLEX® sheet with IN CLAD finishing already applied Pg 97

BRUNEI LNG CARGO PIPE

PROJECT DESCRIPTION:

Country: Korea
 Client: DSME
 Temperature Service: -164°C



KASHAGAN PROJECT

PROJECT DESCRIPTION:

Country: Norway
 Client: AGIP KCO
 Temperature Service: +120°C



AERIAL LNG LOADING SYS- TEM TEST BENCH

PROJECT DESCRIPTION:

Country: France
 Client: Technip
 Temperature Service: -163°C



ISAB PROJECT

PROJECT DESCRIPTION:

Country: Italy
 Client: ISAB - Priolo
 Temperature Service: -110°C



K-FLEX® **IN CLAD SYSTEM**



The **first flexible elastomeric foam** approved by **DNV** for **LNG** and **cryogenic** applications



Site



Video



App. Manual



K-FLEX® IN CLAD SYSTEM

- ▶ Non-metallic flexible coating
- ▶ Designed for oil & gas and industrial use
- ▶ Developed for the most challenging environments
- ▶ High mechanical and chemical resistance
- ▶ Resistance to uv, sea salt, oil and other atmospheric agents
- ▶ Easy to install without special tools
- ▶ Can be applied to any insulation system

K-FLEX® IN CLAD SYSTEM ▶ RANGE

	▼ Length ▼	▼ Thicknesses ▼	▼ Diameters ▼
K-FLEX® IN CLAD - Tubes	1 m	9-13-19-25-32-40-50 mm	from 15 to 168* mm
* For diameters greater than 168 mm, use sheet			
	▼ Thicknesses ▼	▼ Height ▼	
K-FLEX® IN CLAD - Sheets	6-10-13-16-19-25-32-40-50 mm	1000 mm	
K-FLEX® IN CLAD - Adhesive sheets	6-10-13-16-19-25-32-40-50 mm	1000 mm	

ACCESSORIES



Preformed IN CLAD elbows - Gray



Preformed IN CLAD elbows - Black



Preformed "T" connections IN CLAD - Gray



Preformed "T" connections IN CLAD - Black



IN CLAD foil - Gray



IN CLAD foil - Black



IN CLAD tape - Gray

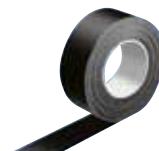

IN CLAD tape - Black



IN CLAD pipe support



IN CLAD pipe support with collar



Silicone

K-FLEX® IN CLAD - THE APPLICATION TOOLS

TOOLS NEEDED FOR THE MANUAL INTERVENTIONS OF THE INSTALLER

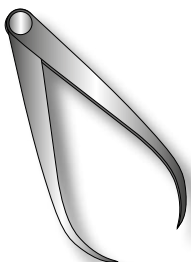

THICKNESS GAUGE

to measure diameters to be transferred on insulating sheets.

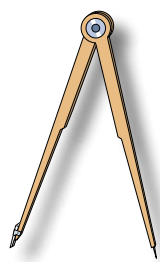

COMPASS

to trace cutting circles.

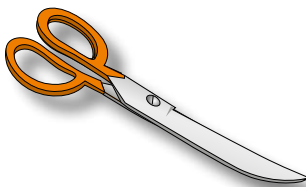

SCISSORS

for cutting shapes.

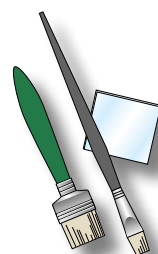

BRUSHES AND SPATULAS

for spreading adhesives.

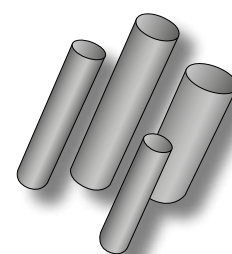

STAMPS

for accurately perforating insulating material.

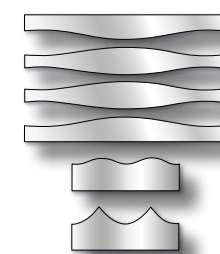

SERIES OF OUTLINES FOR ELBOWS

external Ø outlines from 17 mm - 5" (See the ELBOWS section)

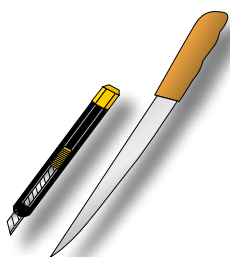

KNIFE AND CUTTER

for different types of cutting.



FLEXIBLE TAPE MEASURE AND RIGID RULER

for measuring and as a guide for cutting and tracing. As a guide for straight cuts one can also use T or L shaped aluminium sections, which give useful hand protection.

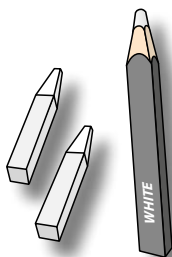

PENCILS AND CHALK

to map out cutting lines.



PUMICE STONE

to sharpen the blades of knives.

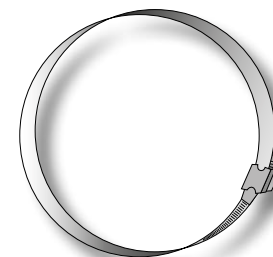

METAL TAPE

to trim the ends of installed tubes and elbows.

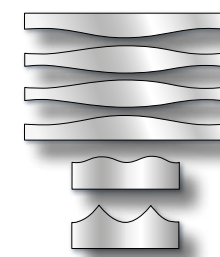

SERIES OF CONNECTING SHAPES

external Ø outlines from 17 mm - 5" (See the "T-pieces" section)

K-FLEX® IN CLAD - APPLICATION TIPS

SOME IMPORTANT TIPS FOR A CORRECT INSTALLATION OF K-FLEX® IN CLAD INSULATION AND FINISHING

INSULATION OF PIPING AND DUCTS WITH K-FLEX® ELASTOMERIC MATERIAL



Before applying the insulating material, clean the pipe surface thoroughly. Avoid applying the insulating material in presence of deposits or defects that may prevent a perfect adhesion. Should you deem it necessary, clean the surface with K-FLEX® thinners.



Always use sharp blades to cut the insulating material cleanly and accurately, so as to prevent any clippings or tearing.

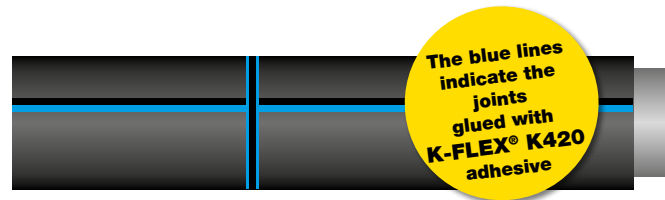

Do not create tension while settling the elastomeric material on the side to be insulated. Always seal the joints of the K-FLEX® insulating material with the correct K-FLEX® ADHESIVE.



Do not apply insulating material in the rain, in humid environments or in the presence of humidity which may prevent a solid adhesion.



Never insulate installations and systems whilst in use. After having completed the insulation, before starting the installation, check the strength of the joints. In the event of losses, wait at least 36 hours before carrying out further checks.

APPLICATION OF THE K-FLEX® IN CLAD FINISHING LAYER



Always use sharp blades to cut the insulating material cleanly and accurately, so as to prevent any clippings or tearing of the finishing layer.

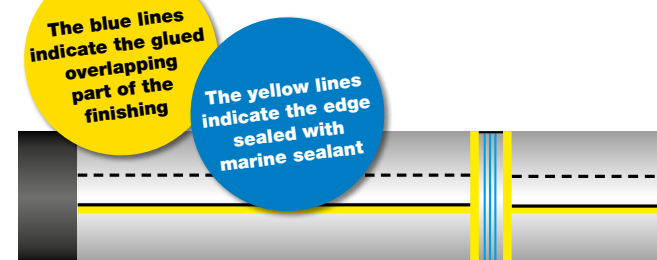
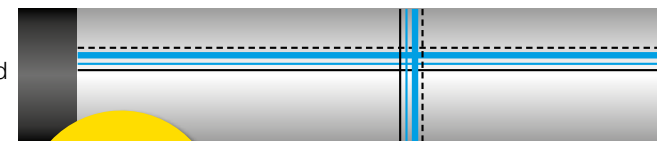

Always carry out overlapping against water to avoid infiltrations and stagnations; for aesthetic purposes, face the overlappings out of sight. For the application sheet use K-FLEX® K 420 ADHESIVE.

For fixing and finishings, only use the specific IN CLAD tapes. The IN CLAD tapes are not adhesive and must be directly applied with K-FLEX® K 420 ADHESIVE. For external applications, the edges of the fixings and the tapes must be sealed with marine sealant (sandpaper the surface if necessary approx. 20mm).

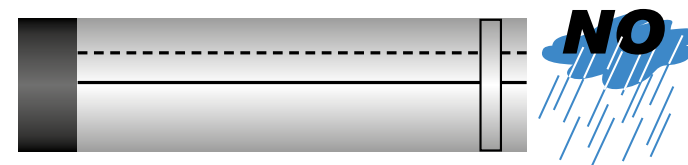

Do not carry out the application finishing in the rain or apply the specific insulation tape in wet environments or in the presence of humidity, which may prevent a solid adhesion.

K-FLEX® IN CLAD TUBES

In the application
sequence the
IN CLAD IG (Grey)
finishing is represented.
The indications are also
the same for the use of
IN CLAD IB (Black)
finishing.





For the application procedures of K-FLEX®
insulating prepared by the installer with sheet
sections, see the relevant sections of the
K-FLEX® APPLICATION GUIDE

If you are not in possession of a printed
guide you can ask for it at our technical dept.
or download the PDF file from our website:
www.kflex.com

MATERIALS

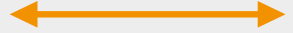
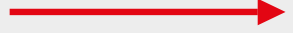

KEY

-  K 420 adhesive
-  Marine sealant
-  Measurements
-  Actions

K-FLEX® IN CLAD - TUBES

INSULATION WITH K-FLEX® ELASTOMERIC SHEETS OR TUBES

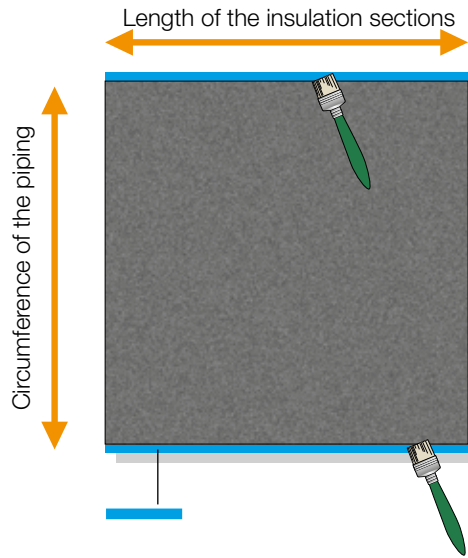

A) Cut from a K-FLEX® insulating sheet a section corresponding to the dimensions of the pipe to insulate and glue the joining edges with K 420 adhesive.

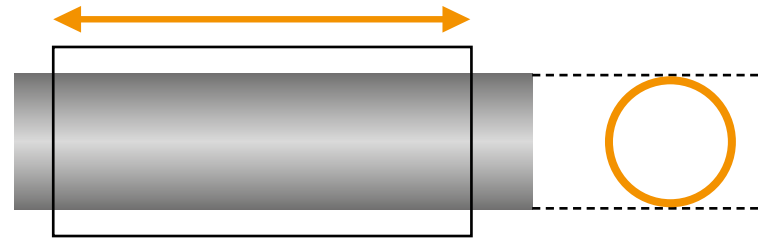

Take the measurements of the circumference wrapping around the piping a strip of elastomeric insulation of the thickness that you are using.

B) Place the sheet on the piping and close the longitudinal joints. Press the glued edges carefully together in order to obtain an even joint, without stretch marks.

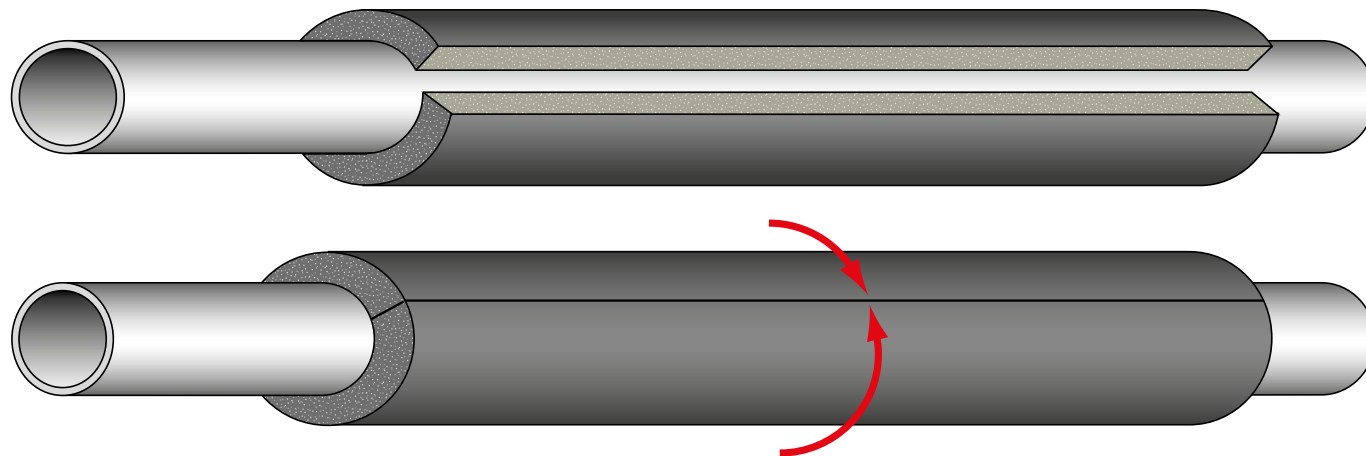
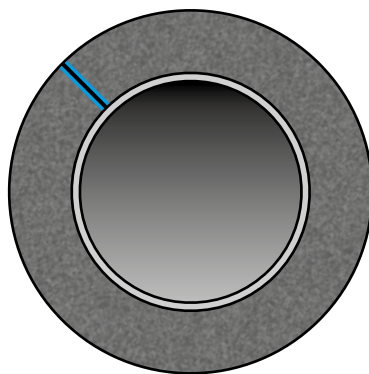

Laying of K-FLEX® elastomeric insulation tube

- ▶ Lay the insulation tube after having cut it lengthwise.
- ▶ Close the tube again fixing the edges of the cut with K 420 adhesive.

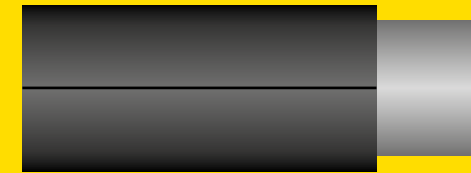

The laying procedure is the same as that illustrated for the K-FLEX® sheet.

MATERIALS



KEY

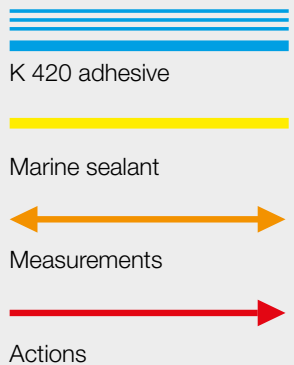

K-FLEX® IN CLAD - TUBES

INSULATION WITH K-FLEX® ELASTOMERIC SHEETS OR TUBES

Laying of the two consecutive K-FLEX® elastomeric sheet or tube
Before proceeding to the appliance of the IN CLAD finishing it is advisable to carry out the complete insulation of a specific part of the plant.

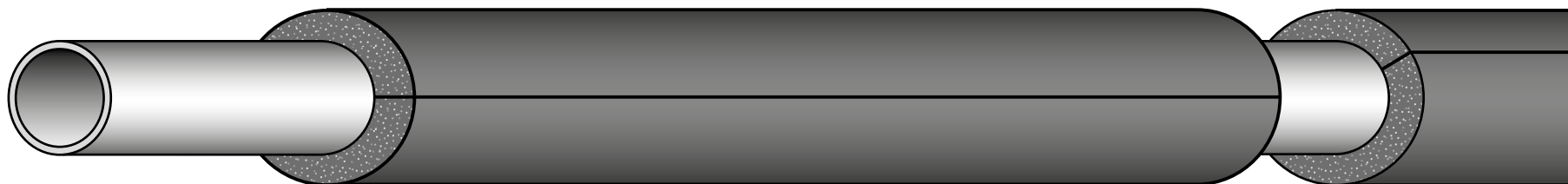

A) Following the assembling procedure on the previous page, lay the next sheet section or insulation tube on the pipe.

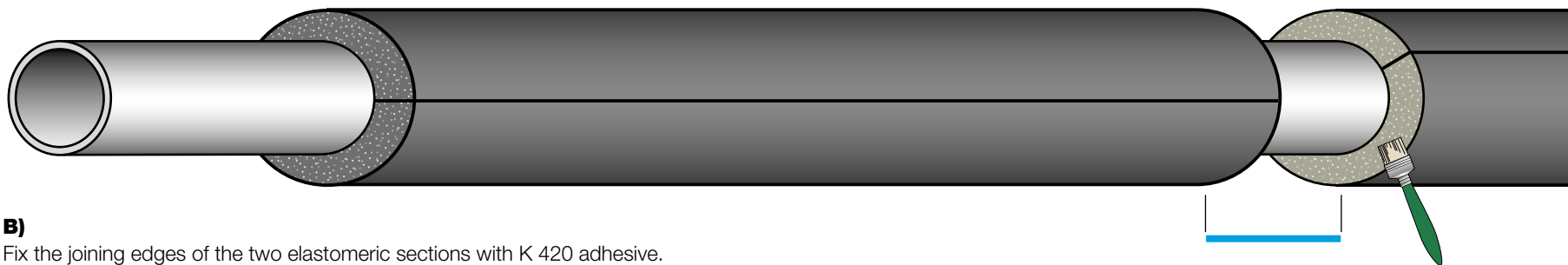

B) Fix the joining edges of the two elastomeric sections with K 420 adhesive.



C) Bring into contact the two sections and close the longitudinal joints carefully pressing together the glued edges in order to obtain an even result, without stretch marks.

MATERIALS



KEY



K 420 adhesive



Marine sealant



Measurements



Actions

K-FLEX® IN CLAD - TUBES

APPLICATION OF THE IN CLAD COVERING SHEET ON K-FLEX® ELASTOMERIC INSULATION

Laying of the IN CLAD standard finishing sheet

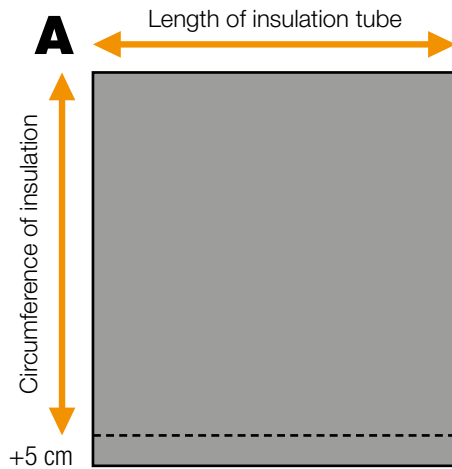

A) Cut from an IN CLAD sheet a section of a height corresponding to the circumference of the insulation tube plus 5 cm of abundance for the overlap, and of the length of the insulation section to cover.

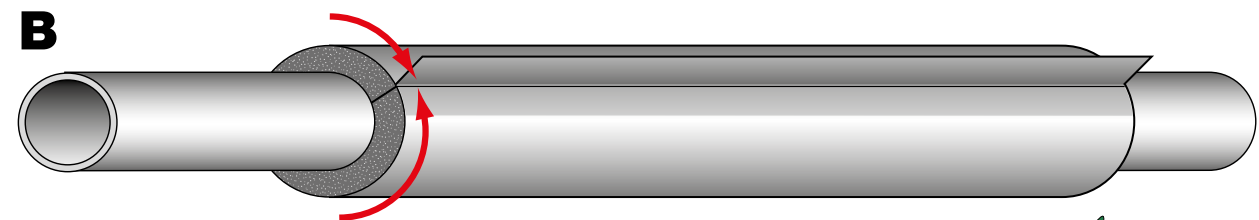

B) Place the sheet on the piping arranging the longitudinal joints against water.

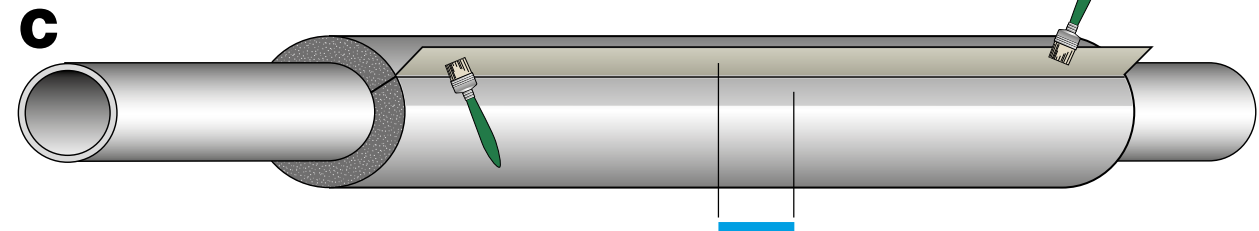

C) Glue the joining edges with K 420 adhesive.



D) Close the joints. If necessary, seal the joints with the specific IN CLAD tape secured with glue.

MATERIALS



KEY



K 420 adhesive



Marine sealant



Measurements



Actions

K-FLEX® IN CLAD - TUBES

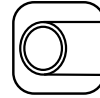

APPLICATION OF THE IN CLAD COVERING SHEET ON K-FLEX® ELASTOMERIC INSULATION

Application of two consecutive sections of sheet.

A)

Install a section of sheet (I) following the procedure illustrated on the previous page.

Preparation for applying sheet II

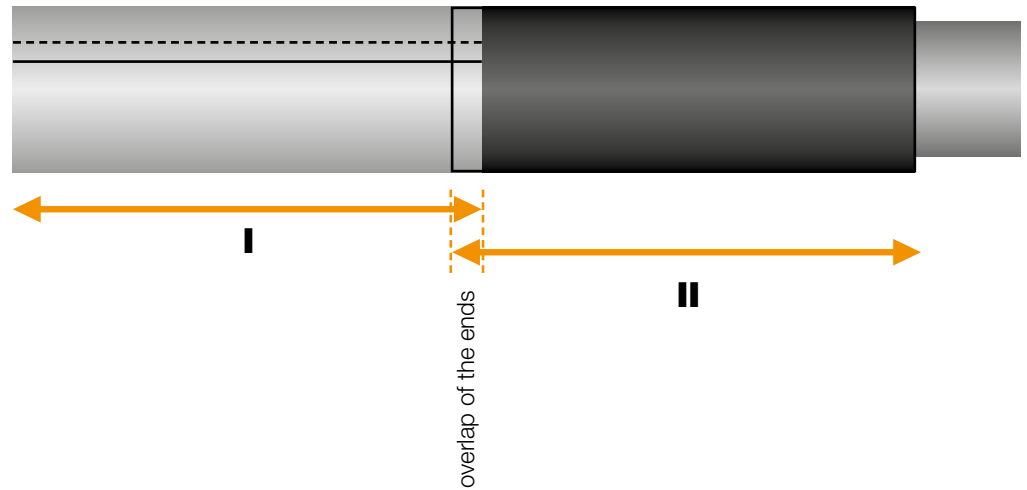
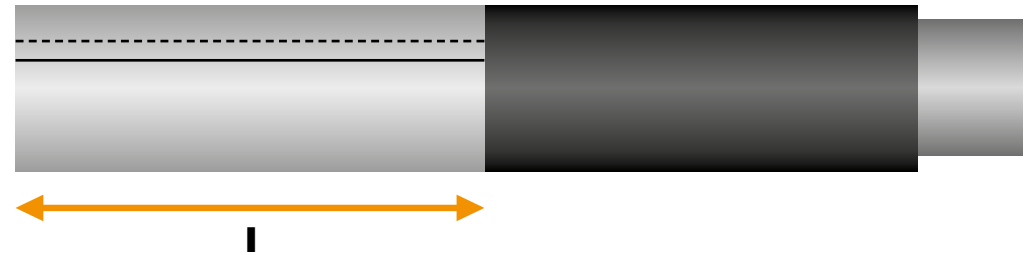
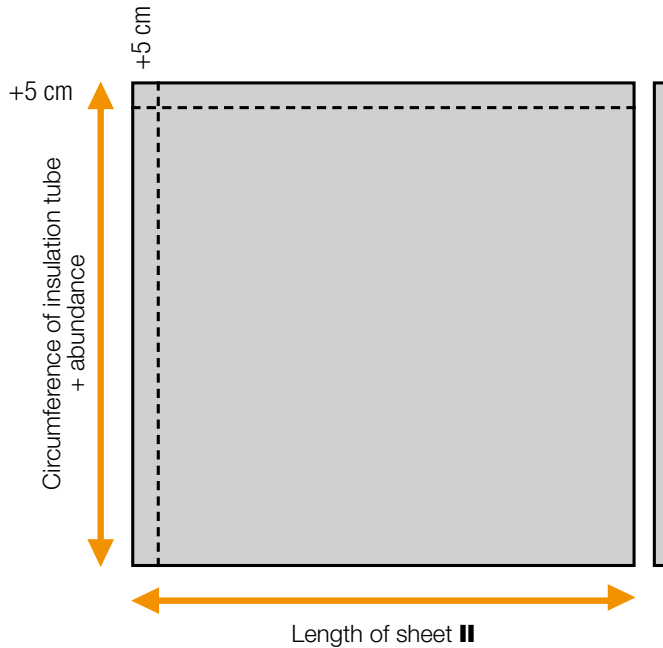

B)

Cut another section of IN CLAD sheet (II) the same as the previous one (I) but 5 cm longer to allow for overlapping of the end.

MATERIALS



KEY



K 420 adhesive



Marine sealant

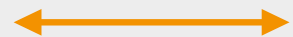

Measurements



Actions

K-FLEX® IN CLAD - TUBES

APPLICATION OF THE IN CLAD COVERING SHEET ON K-FLEX® ELASTOMERIC INSULATION

Preparation for applying sheet II

A1

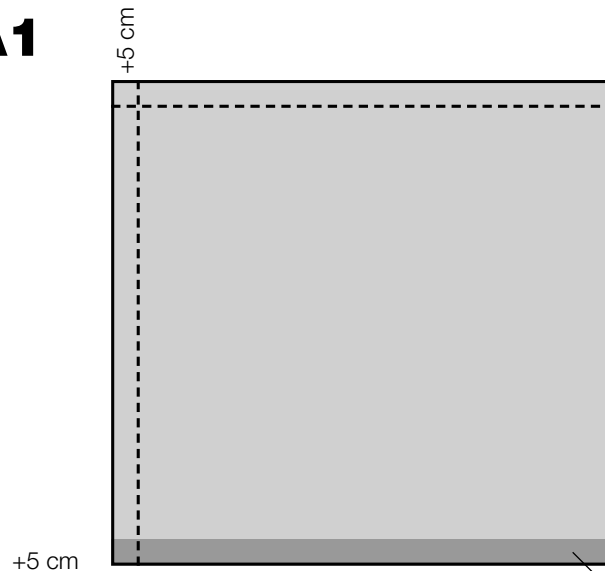

A2

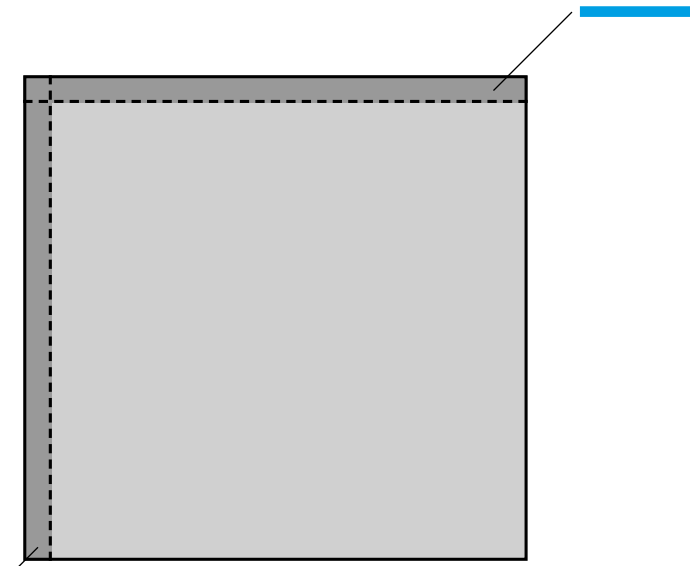

A1 - A2)

Apply glue for fixing.

B)

On sheet I, already placed, apply glue for fixing.

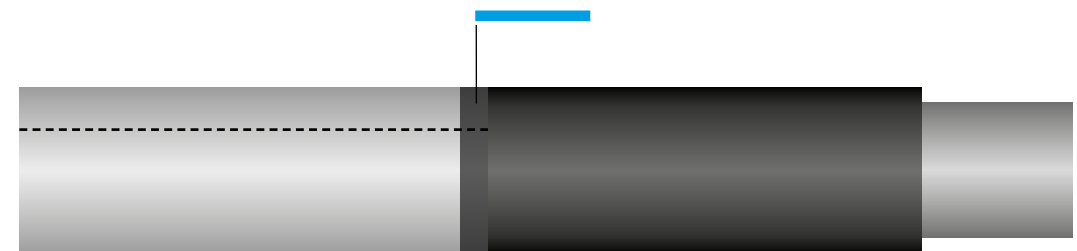

I

B

MATERIALS



KEY



K 420 adhesive

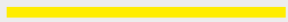

Marine sealant



Measurements



Actions

K-FLEX® IN CLAD - TUBES



APPLICATION OF THE IN CLAD COVERING SHEET ON K-FLEX® ELASTOMERIC INSULATION

A)

Install sheet **II** so that it overlaps sheet **I**. Always turn the overlap against the flow of water and out of sight.

B)

Close sheet **II** with controlled pressure to obtain an even result without stretch marks. apply glue for fixing.

C)

If necessary, seal the joints with the specific IN CLAD tape secured with glue. Seal all visible joints with silicone.

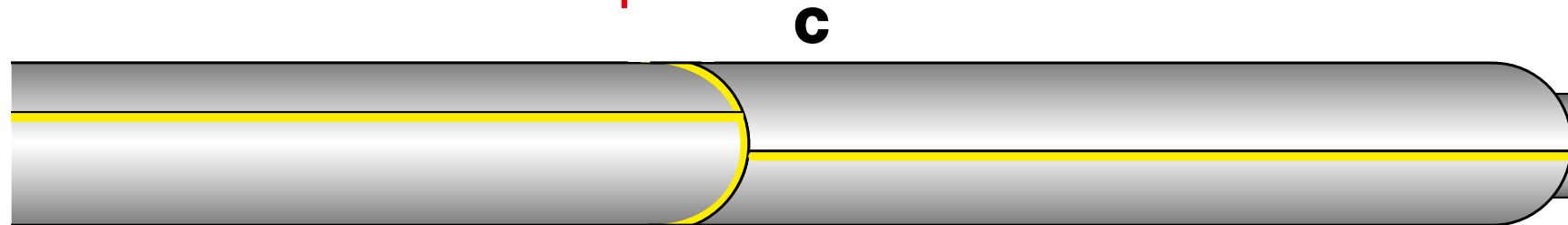
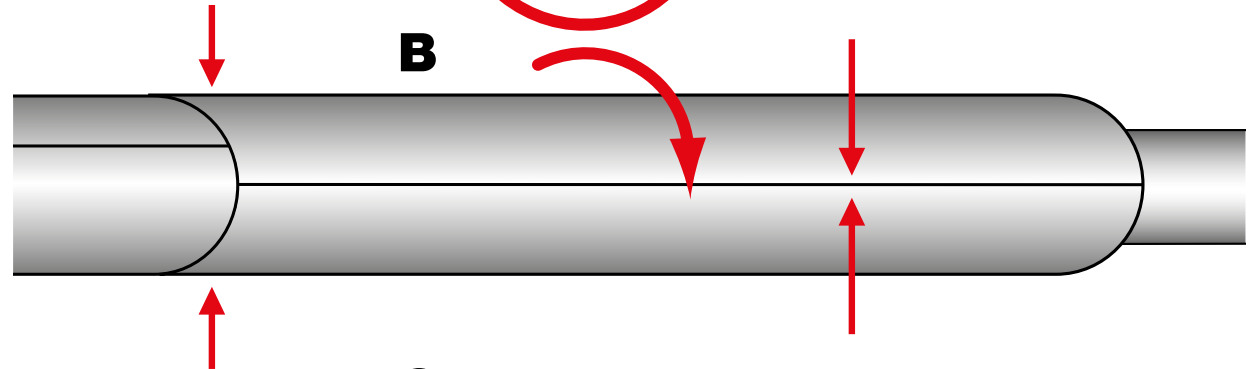
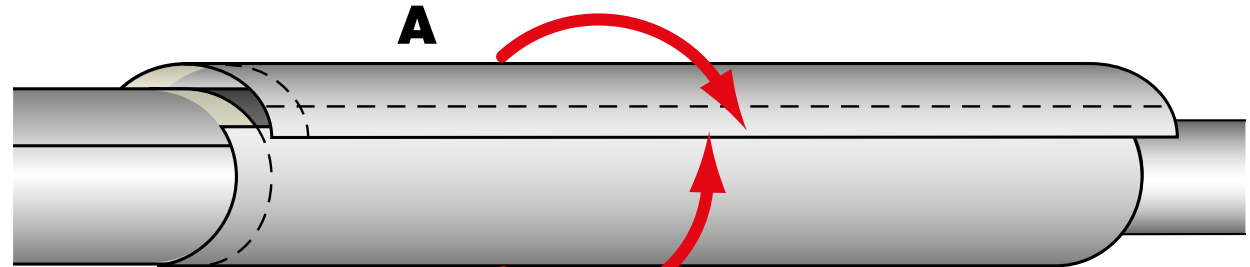

MATERIALS



KEY



K 420 adhesive

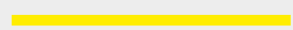

Marine sealant

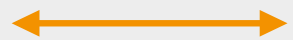

Measurements



Actions

K-FLEX® IN CLAD - TUBES

K-FLEX® SHEETS WITH IN CLAD COVERING PRE-APPLIED

Application of IN CLAD covering sheet on an insulation tube

A)

Cut a section from a K-FLEX® IN CLAD sheet corresponding to the circumference of the piping to insulate, with an abundance of 5 cm, for the overlapping of the edges.

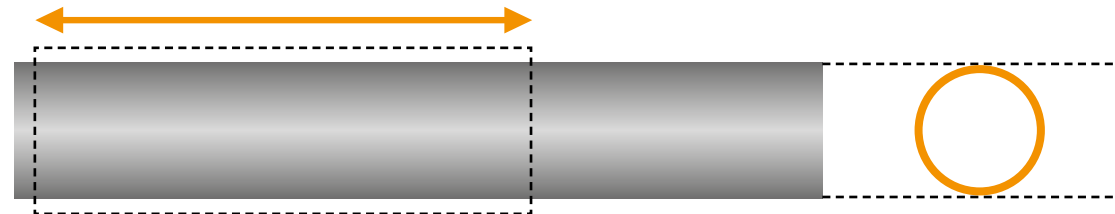
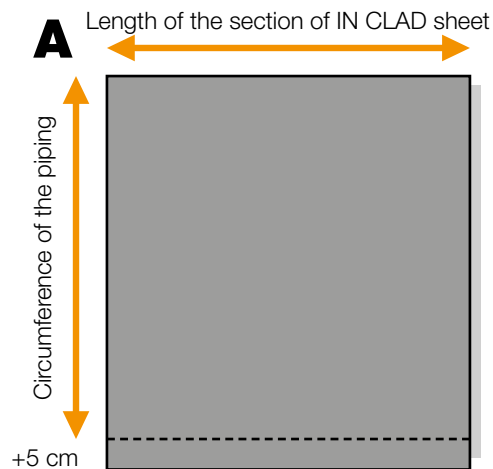

B)

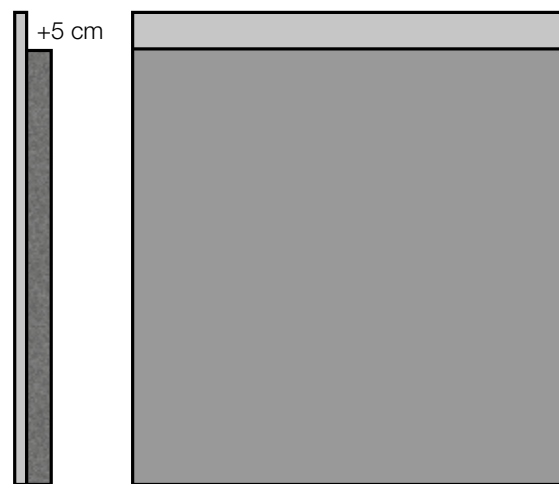

B)

Remove a strip of 5 cm from the elastomeric layer where the abundance is, leaving the IN CLAD sheet intact.

For the operation, make a clean cut in the elastomer and remove the remaining material from the sheet with a scraper.

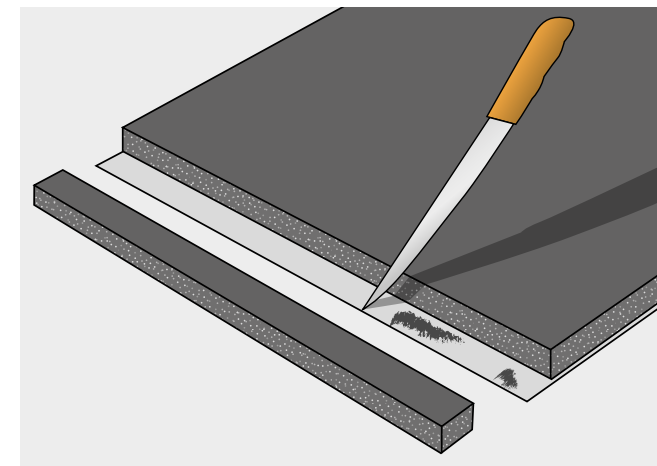

The illustration shows the operation for obtaining the necessary overlap for the construction of the joints.

As a makeshift solution, without doubt less effective, cut a section of sheet without leaving an abundance and simply cover the joints with IN CLAD adhesive, following the specific appliance rules.

MATERIALS



KEY



K 420 adhesive



Marine sealant



Measurements



Actions

K-FLEX® IN CLAD - TUBES

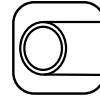

K-FLEX® SHEETS WITH IN CLAD COVERING PRE-APPLIED

Placing of the tube with pre-applied covering

A)

Place the prepared sheet on the pipe to check the dimensions.
Turn the closure of the overlap against water.

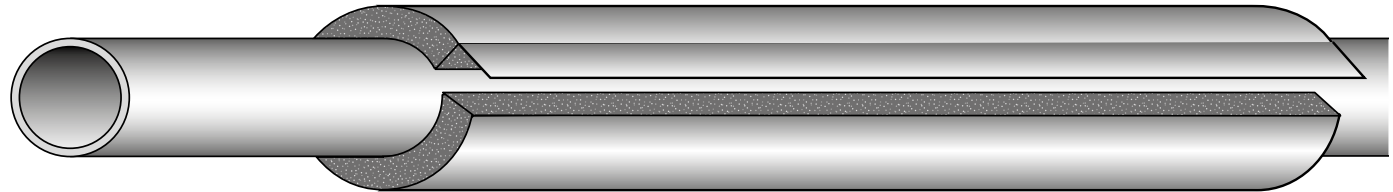

B)



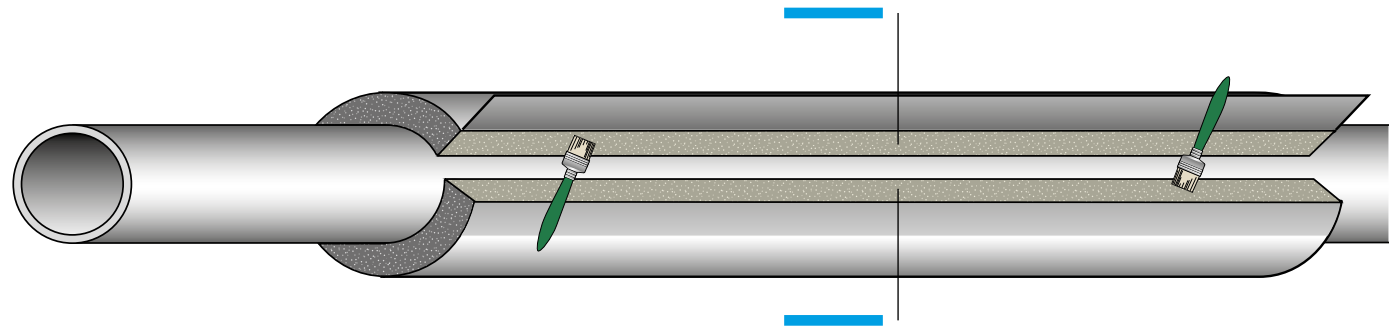

Glue the joining edges of the elastomeric layer with K 420 adhesive.



MATERIALS



KEY

-  K 420 adhesive
-  Marine sealant
-  Measurements
-  Actions

K-FLEX® IN CLAD - TUBES

K-FLEX® SHEETS WITH IN CLAD COVERING PRE-APPLIED

A)

Join the elastomer edges using careful pressure to obtain an even closure, without stretch marks.

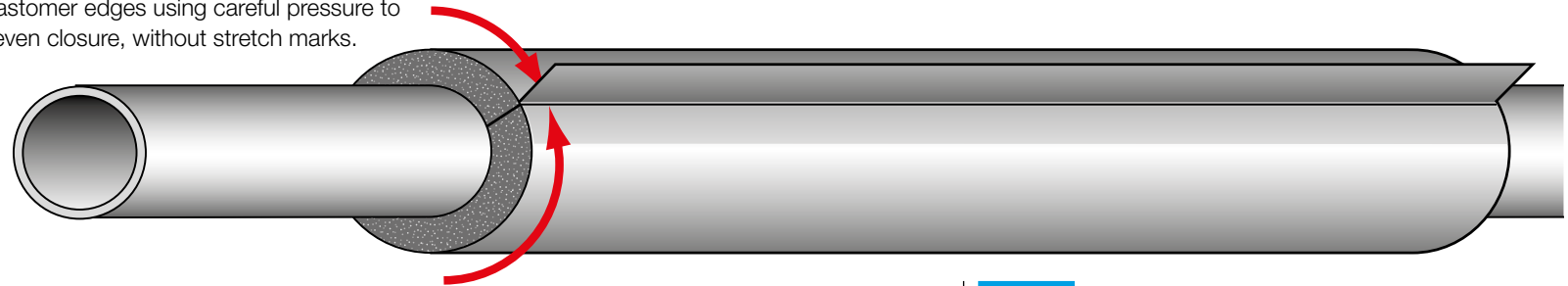

B)

Glue the which will be sealed together.

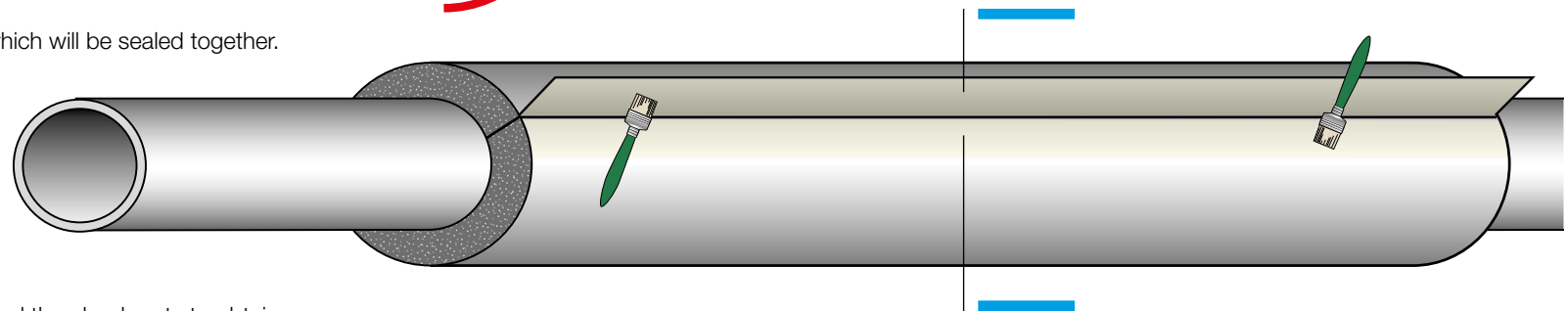

C)

Carefully seal the glued parts to obtain an even closure, without stretch marks. If necessary, seal the joints with the specific IN CLAD tape secured with glue.



MATERIALS



KEY



K 420 adhesive

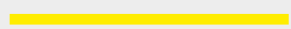

Marine sealant



Measurements



Actions

K-FLEX® IN CLAD - TUBES



K-FLEX® SHEETS WITH IN CLAD COVERING PRE-APPLIED

Preparation of tube II with covering pre-applied

A)

Cut a section of K-FLEX® IN CLAD corresponding to the circumference of the pipe to insulate, including an abundance of 5 cm to allow for overlapping of the longitudinal joint. Leave another abundance of 5 cm on the side which will be joined to the tube already installed.

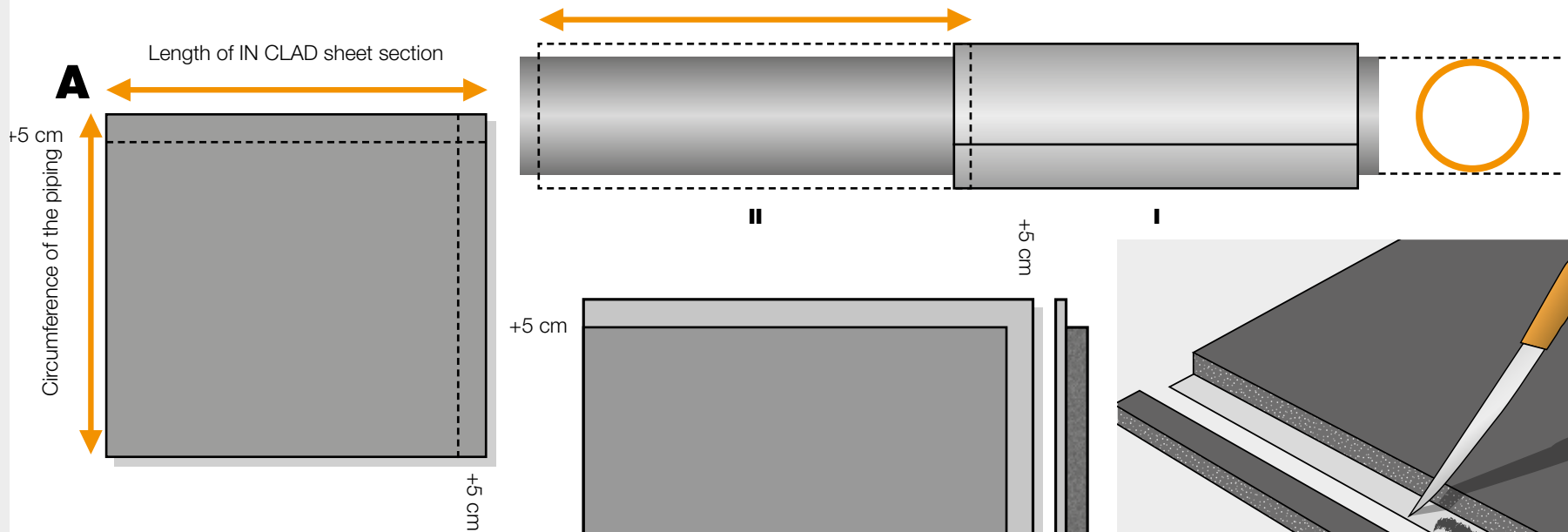

B)

Remove the two strips of 5 cm from the elastomeric layer where the abundance is, leaving the IN CLAD sheet intact.

For the operation, make a clean cut in the elastomeric sheet and remove the remaining material with a scraper.

B

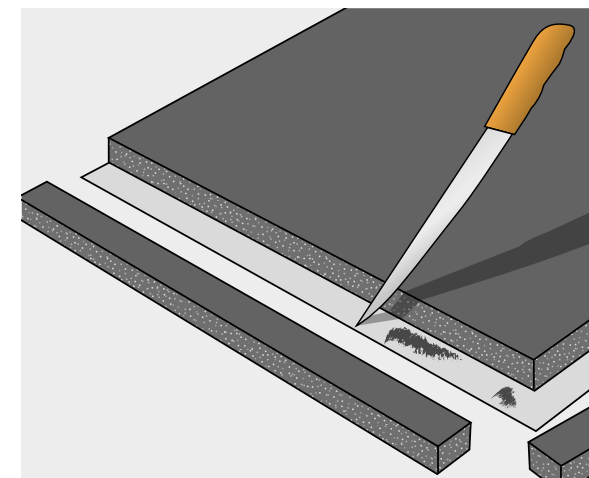
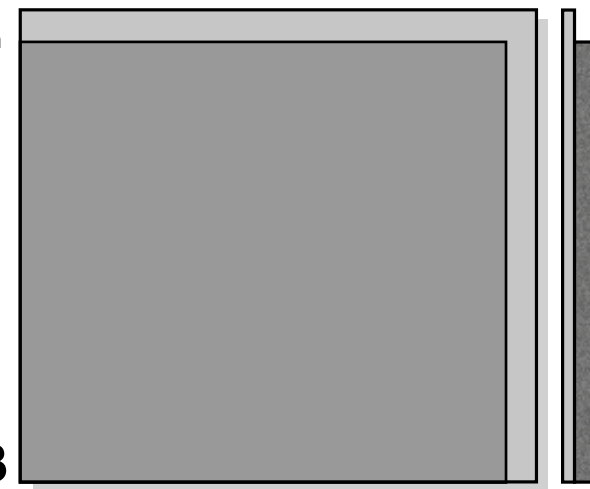

The illustration shows the operation to obtain the overlap necessary for the joints.

As a makeshift solution, without doubt less effective, cut the sheet sections without leaving an abundance and, after having glued the elastomeric parts, cover the joints with IN CLAD tape, following the correct application instructions.

MATERIALS



KEY



K 420 adhesive



Marine sealant

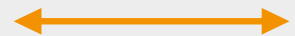

Measurements



Actions

K-FLEX® IN CLAD - TUBES

K-FLEX® SHEETS WITH IN CLAD COVERING PRE-APPLIED

Placing of tube II with covering pre-applied

A)
Glue the edges of the longitudinal joints of the elastomeric sheet with K 420 adhesive.

B)
Seal the elastomeric edges.

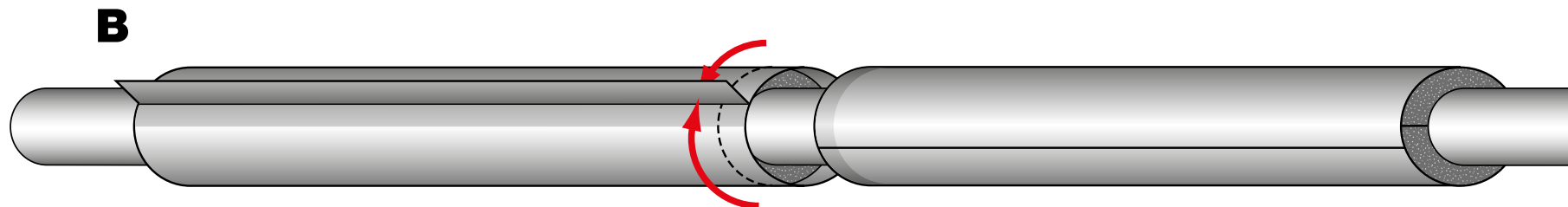
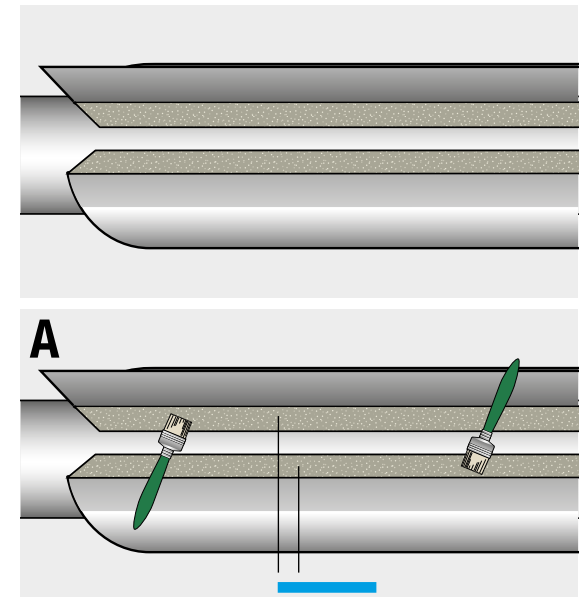
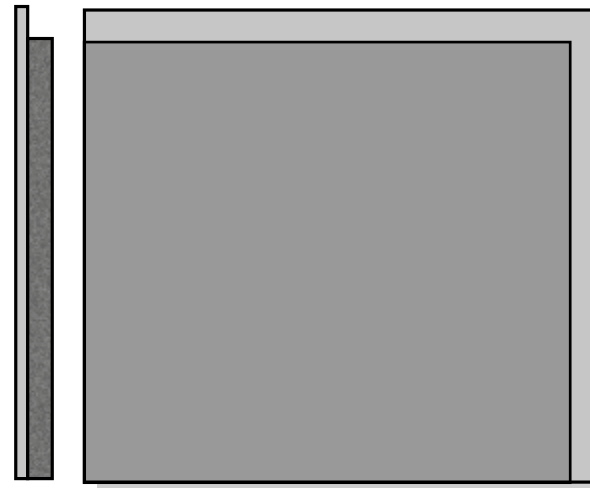

MATERIALS



KEY

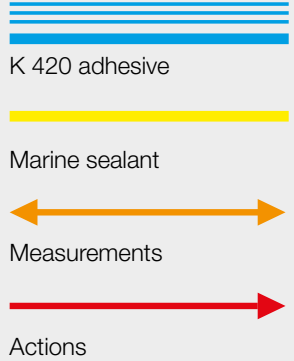

K-FLEX® IN CLAD - TUBES

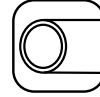

K-FLEX® SHEETS WITH IN CLAD COVERING PRE-APPLIED

A)

Glue the two elastomeric ends of the two tubes with K 420 and seal together (**A1**).
Glue the internal sides of the overlap and the end of tube **I** (**A2**).

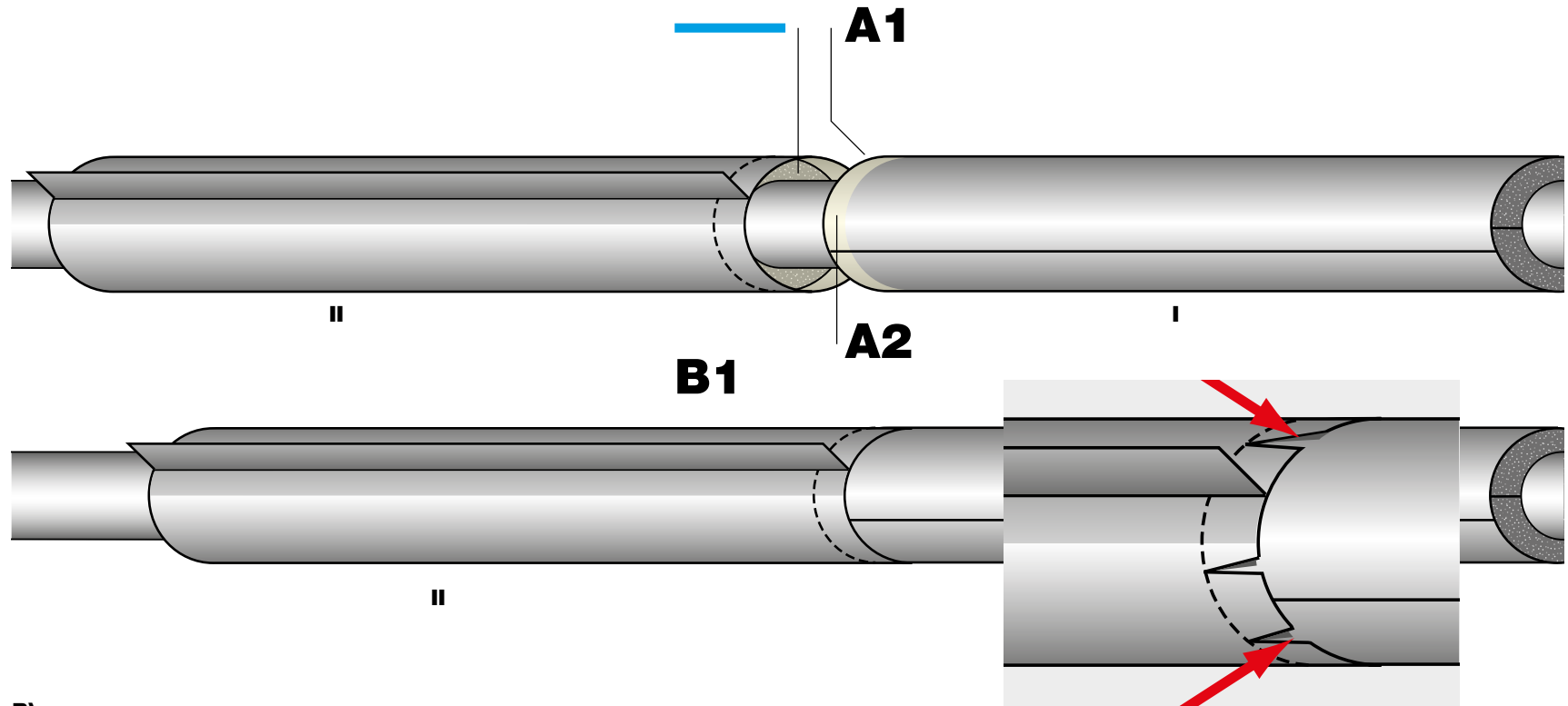

B)

Push tube **II** onto tube **I** until the elastomeric heads, which should adhere firmly, come into contact.
It would be useful to make cuts in the overlap to facilitate the insertion of tube **I** (**B2**).
Fix the end parts of **I** to the walls of the female overlap of tube **II**.

If cuts are made in the overlap it is necessary to seal the covering with IN CLAD tape applied with glue.

MATERIALS

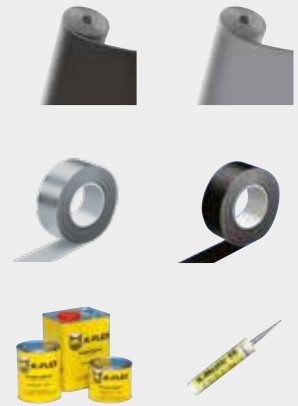

KEY

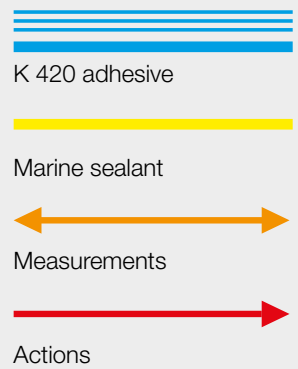

K-FLEX® IN CLAD - TUBES

K-FLEX® SHEETS WITH IN CLAD COVERING PRE-APPLIED

A)
Glue the sides of the longitudinal joint of tube II.

B)
When installation is complete seal the longitudinal edge.

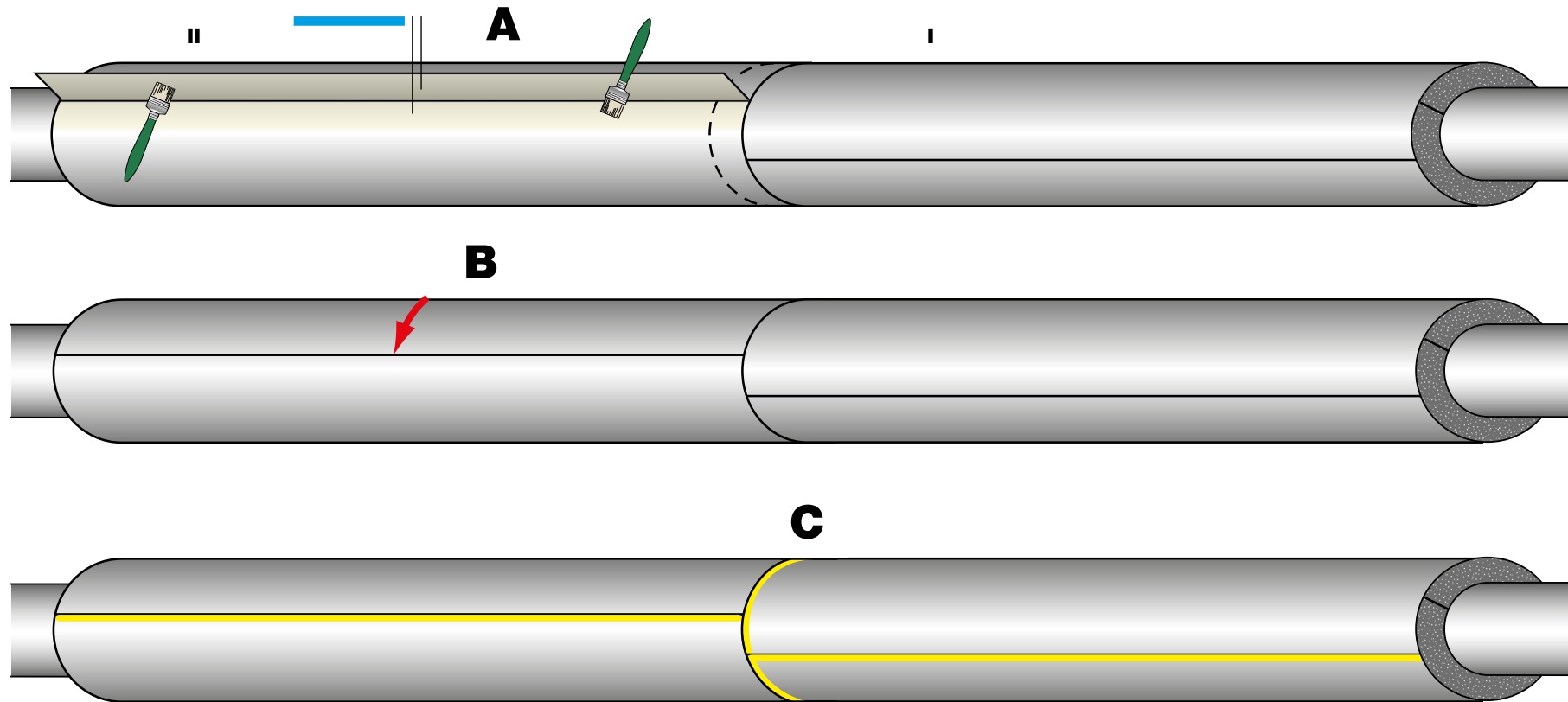

c)
For external applications, seal the visible joints with marine sealant. If necessary, seal the joints with the specific IN CLAD tape secured with glue.

MATERIALS



KEY



K 420 adhesive



Marine sealant



Measurements



Actions

K-FLEX® IN CLAD - TUBES

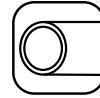

PRE-CUT TUBE WITH IN CLAD COVERING PRE-APPLIED

The covering of the product is equipped with an overlap, with male-female extremities, to help slotting tubes into others (**A1**). The pre-cut tube is also equipped with an overlap to seal the longitudinal cut (**A2**)

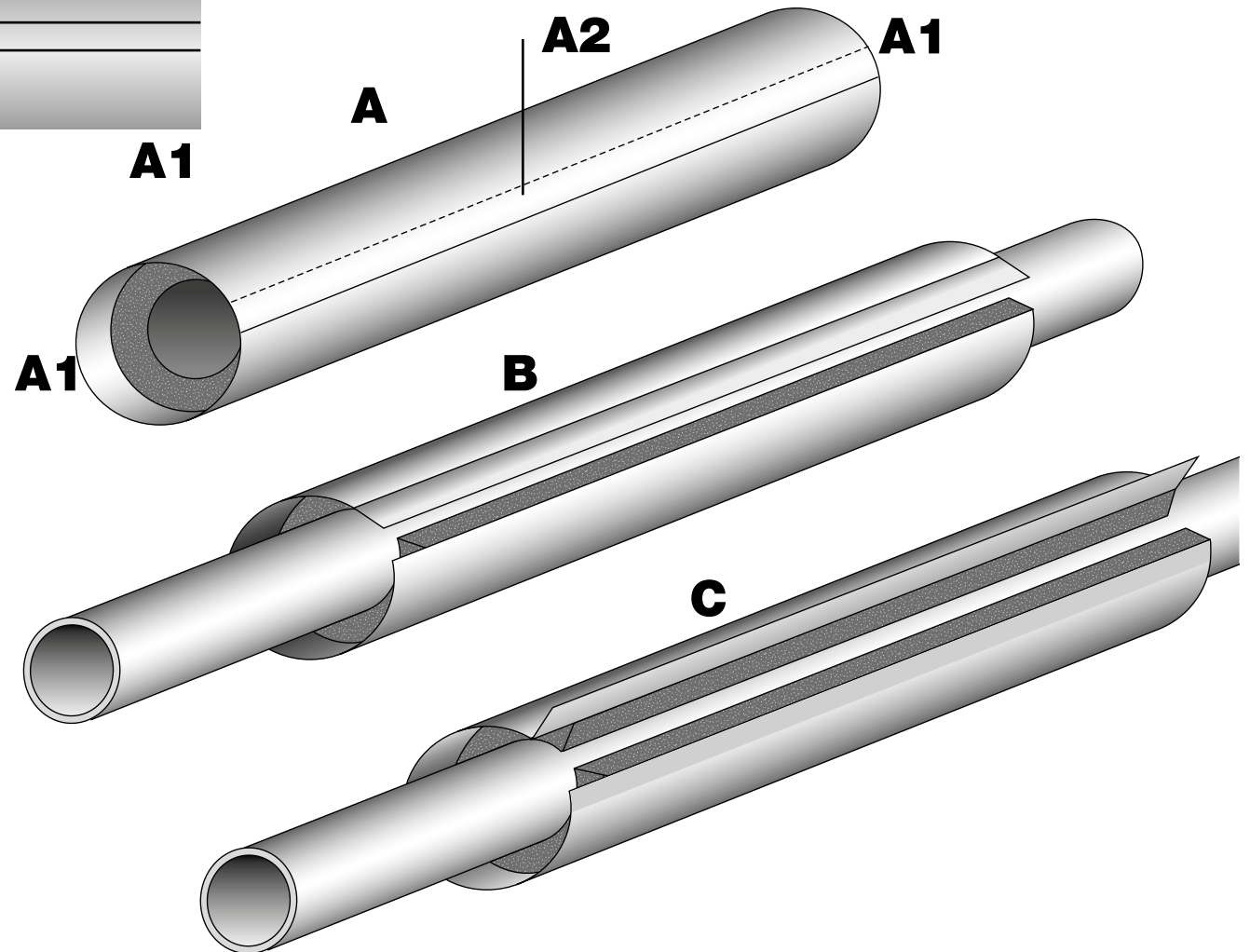
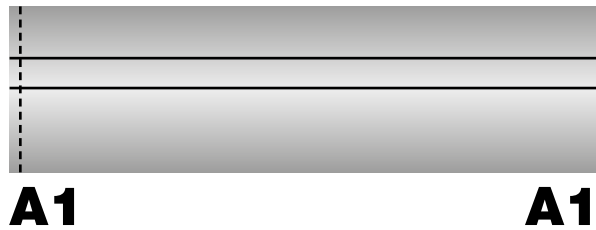

B) Open the pre-cut tube and install it on the section of pipe to be covered.

When the K-FLEX® IN CLAD tube is opened, the edges of the internal elastomeric layer will be visible.

C) The flexibility of the sheet allows the overlap to be folded back in order to carry out the necessary installation procedure.

MATERIALS



KEY



K 420 adhesive



Marine sealant



Measurements



Actions

K-FLEX® IN CLAD - TUBES

PRE-CUT TUBE WITH IN CLAD COVERING PRE-APPLIED

A)

Glue the cut elastomeric edges with K 420 adhesive.

The operation can be easily carried out on a work bench. In this case the K-FLEX® IN CLAD tube will be installed on the pipe ready to be sealed.

B)

Join the elastomeric edges together using appropriate pressure to obtain an even adhesion, without creating stretch marks.

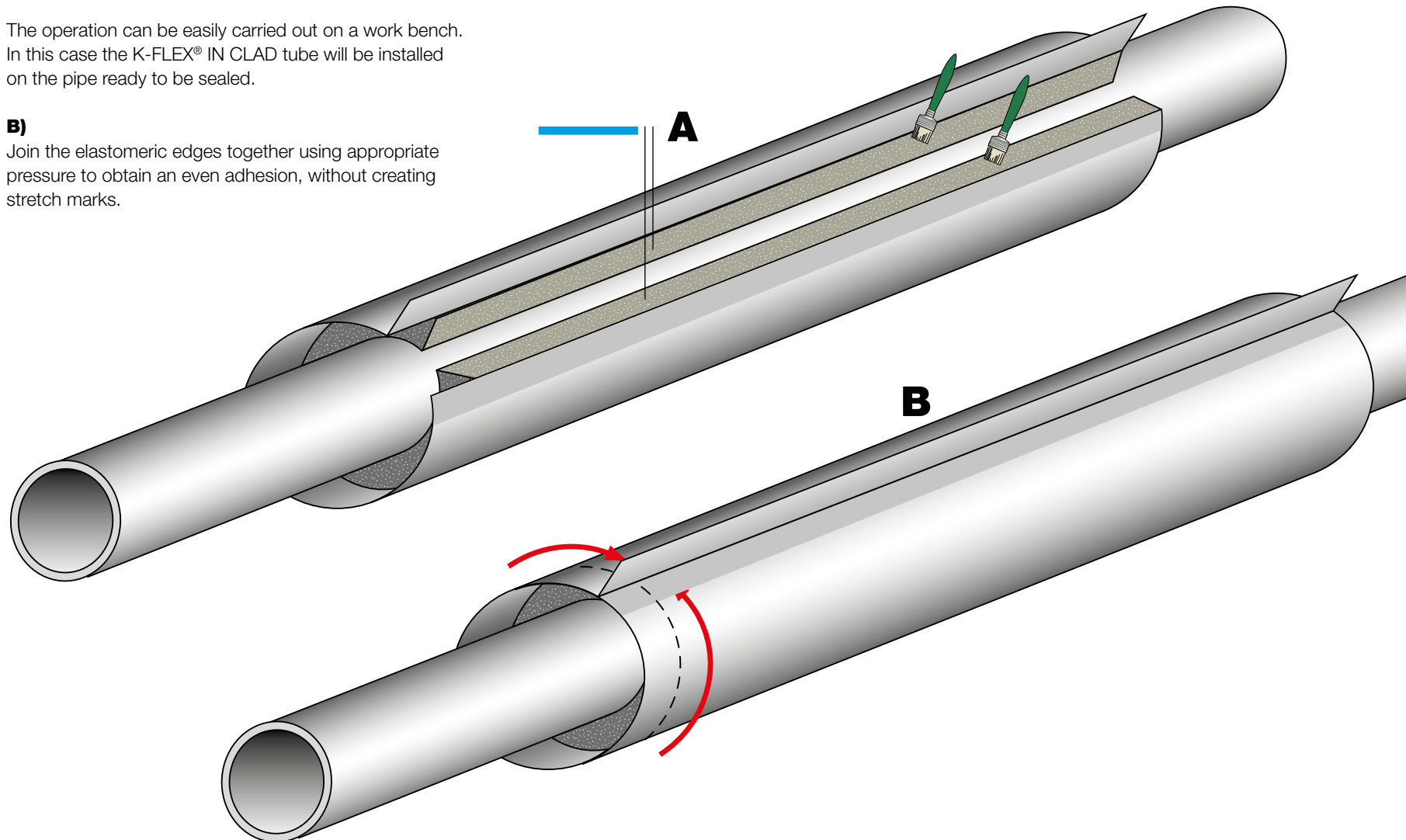

MATERIALS



KEY



K 420 adhesive



Marine sealant



Measurements



Actions

K-FLEX® IN CLAD - TUBES

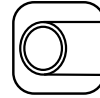

PRE-CUT TUBE WITH IN CLAD COVERING PRE-APPLIED

A)

Glue the overlap (**A1**).

B)

Close the longitudinal overlap, except for the last part.

This action will be useful when inserting the next tube.

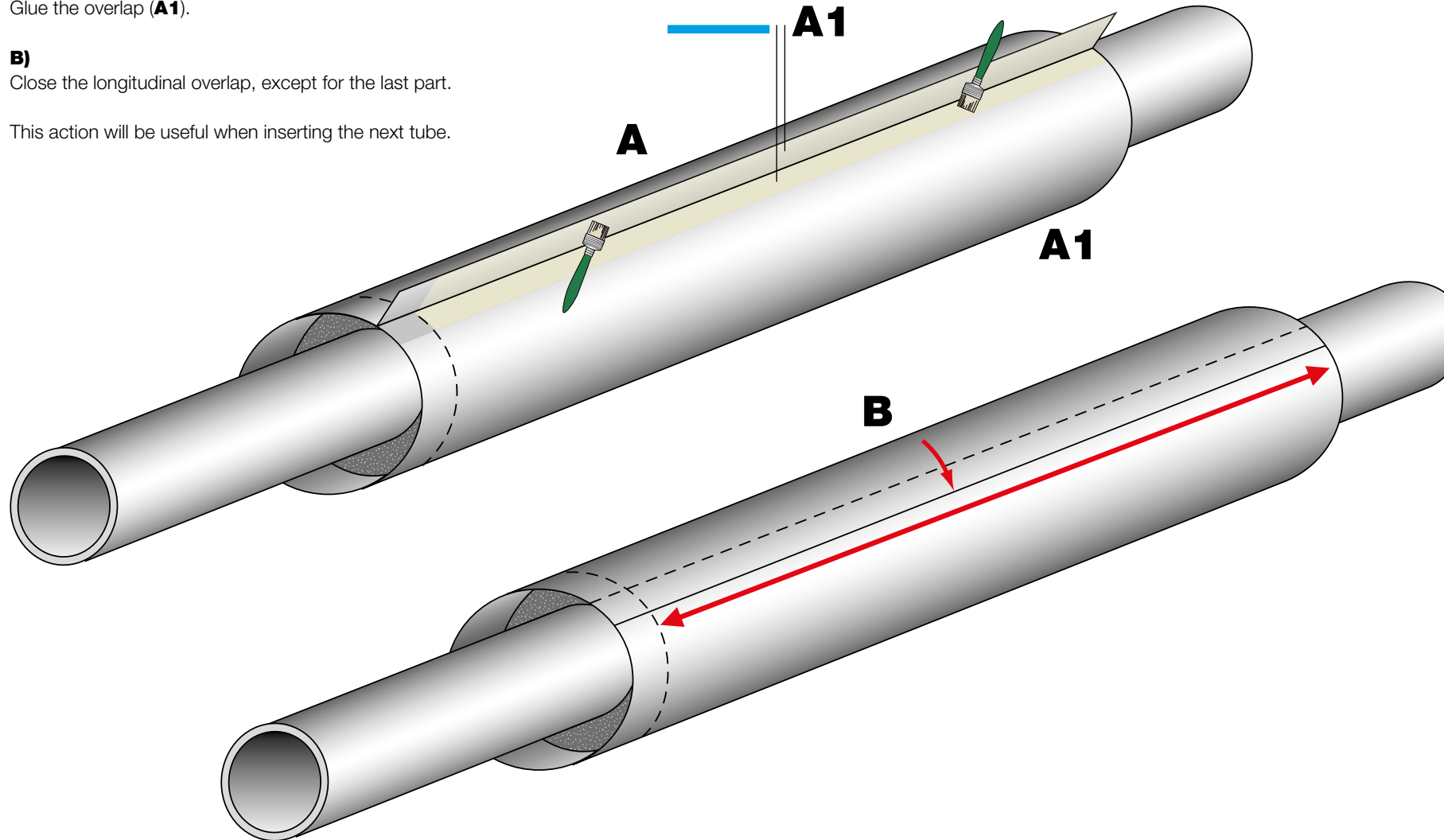

MATERIALS



KEY



K 420 adhesive



Marine sealant



Measurements



Actions

K-FLEX® IN CLAD - TUBES

PRE-CUT TUBE WITH IN CLAD COVERING PRE-APPLIED

A)

With the same procedure illustrated so far, place the next tube (II), with the male part turned towards the female part of the first tube (I). In order to obtain a stronger grip it is advisable not to align the two longitudinal joints (**A1-A2**).

B)

Apply K 420 adhesive on both the joining ends of the elastomeric sheet (**B1**).

Glue the internal wall of the female overlap (**B1**).

Also glue the end of tube II, which will be inserted into the female overlap of tube I (**B3**).

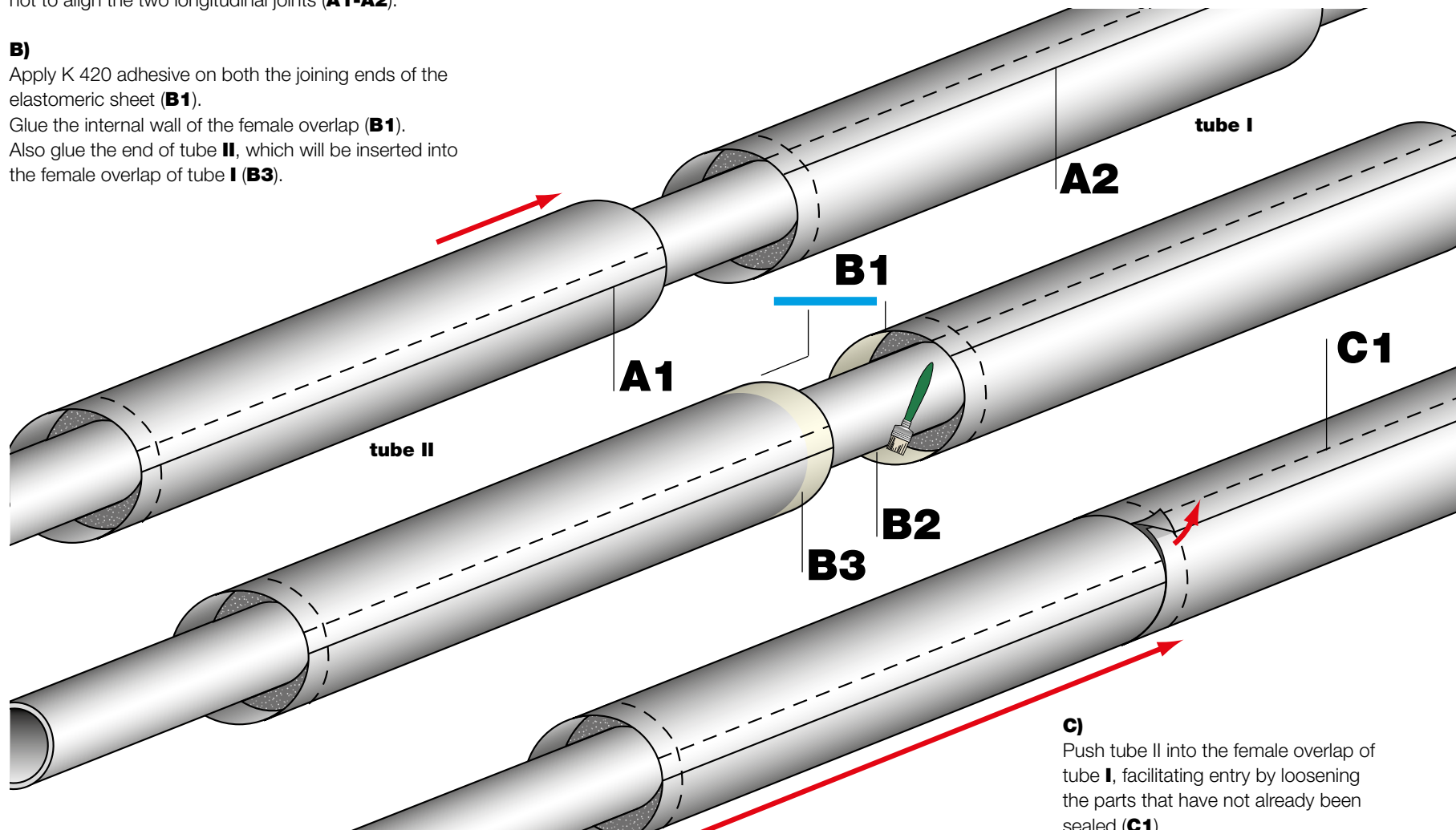



C)

Push tube II into the female overlap of tube I, facilitating entry by loosening the parts that have not already been sealed (**C1**).

MATERIALS

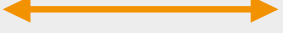
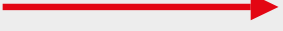

KEY

-  K 420 adhesive
-  Marine sealant
-  Measurements
-  Actions

K-FLEX® IN CLAD - TUBES

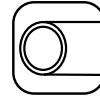

PRE-CUT TUBE WITH IN CLAD COVERING PRE-APPLIED

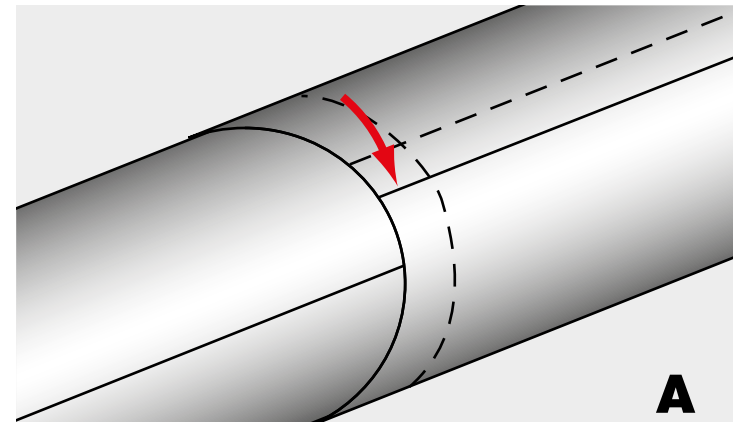
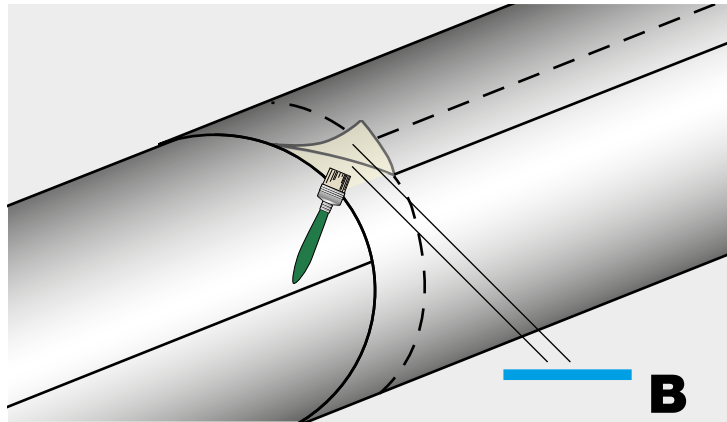

A) Close the female overlap onto the end of the male tube. Lift the edge of the longitudinal overlap which is still free, and seal it with the correct adhesive. Also glue the underlying area.

B) Complete the closure of the overlap.

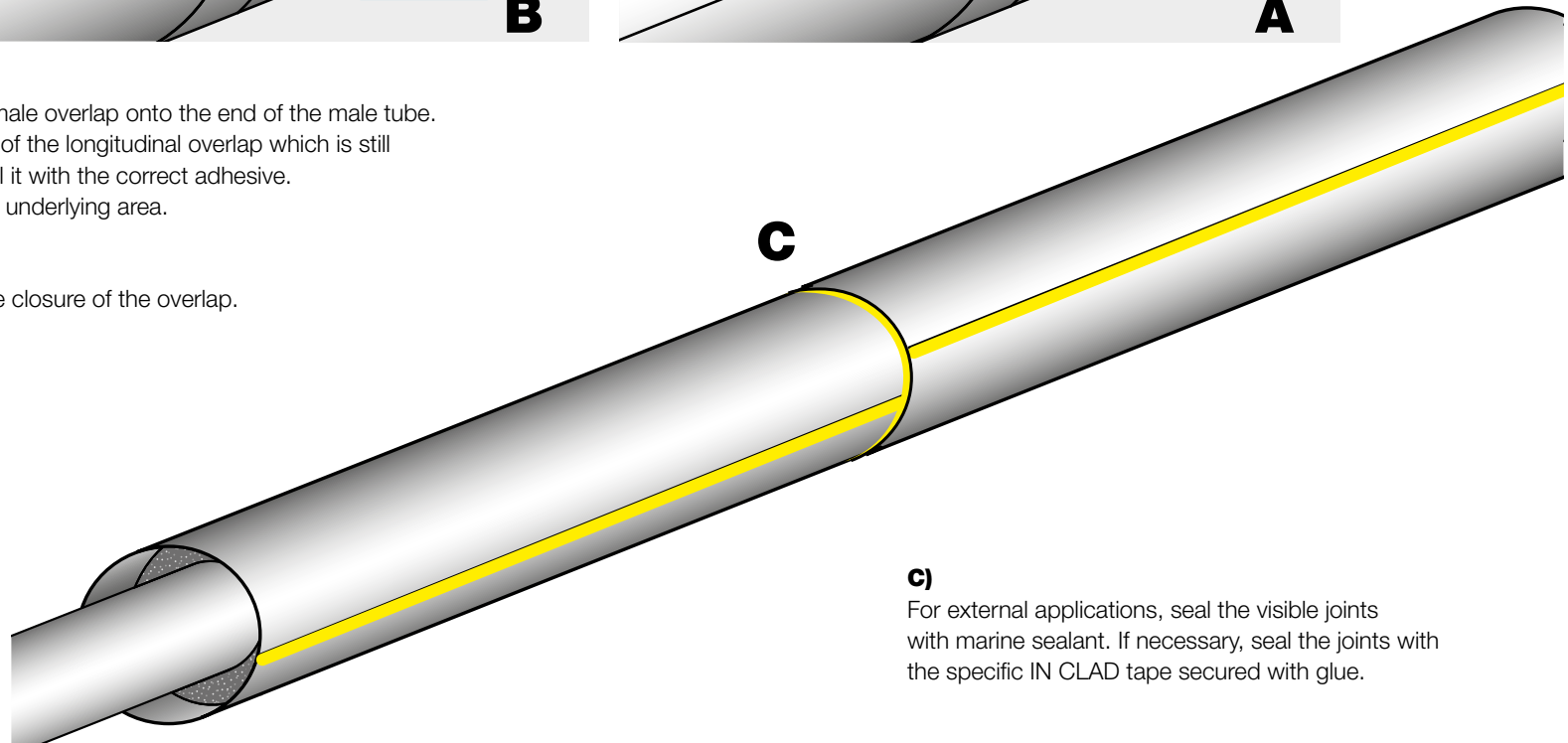

c) For external applications, seal the visible joints with marine sealant. If necessary, seal the joints with the specific IN CLAD tape secured with glue.

K-FLEX® IN CLAD ELBOWS

In the application sequence the **IN CLAD IG (Grey)** finishing is represented. The indications are also the same for the use of **IN CLAD IB (Black)** finishing.



For the application procedures of K-FLEX® insulating prepared by the installer with sheet sections, see the relevant sections of the K-FLEX® APPLICATION GUIDE

If you are not in possession of a printed guide you can ask for it at our technical dept. or download the PDF file from our website: www.kflex.com

MATERIALS



K-FLEX® IN CLAD - ELBOWS



INSTALLATION OF PRE-SHAPED K-FLEX® ELBOWS

Installing K-FLEX® pre-shaped elbows is extremely easy:

- A)** Place the K-FLEX® elbow around the pipe.
- B)** With K420 adhesive, glue the edges of the throat and seal them together.
- C)** Having completed the installation of the elbow, proceed to the application of the tubes, gluing the joints with K420 adhesive.

KEY



K 420 adhesive



Marine sealant

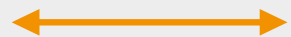

Measurements



Actions

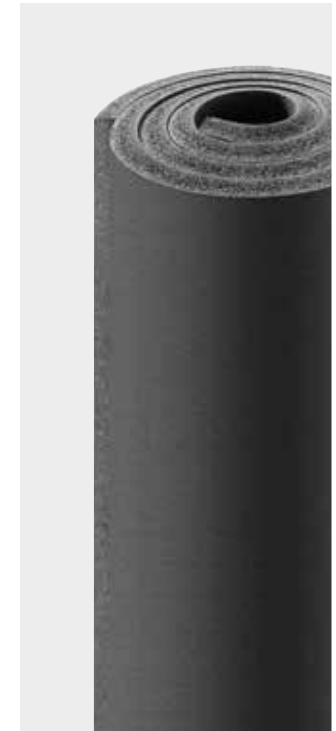
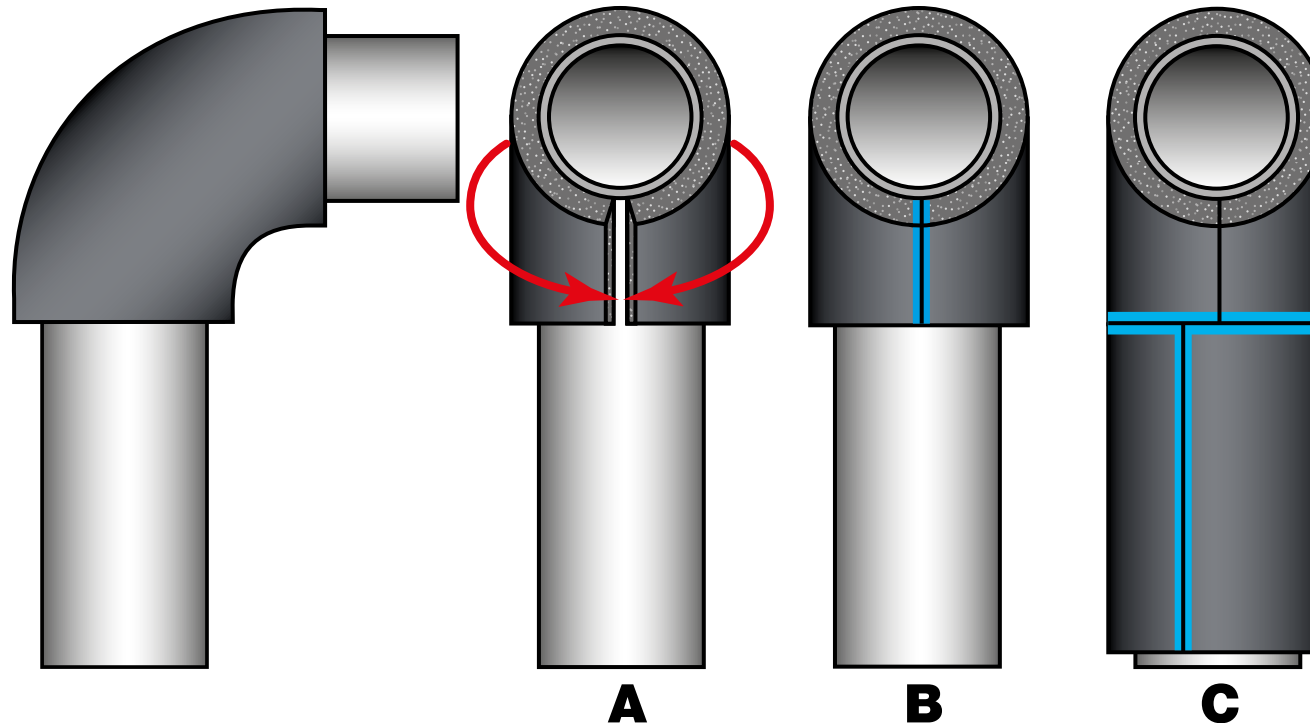

For the preparation of insulating elbows by the installer using sections of K-FLEX® sheet, consult the relevant section of the "K-FLEX® APPLICATION MANUAL"

MATERIALS



K-FLEX® IN CLAD - ELBOWS



FINISHING OF ELBOWS WITH IN CLAD SHEET

How to arrange the covering shapes to form an elbow.

A) After having prepared an insulated elbow, pre-shaped or completely prepared by the installer, and having insulated the adjacent tubes, apply the covering to the insulated tubes leaving an abundance of 5 cm (**A1-A2**) to allow for overlapping the elbow covering.

B) Apply the segments of IN CLAD (black or grey colour) sheet on the elbow. For the correct type of shape see the example on the following page. For the joints of the segments, overlap the abundances prepared in advance against the flow of water. For this reason the mounting sequence of the segments is carried out starting from the lowest part (see numbering **1-2-3-4**, referring to a four section elbow covering).

KEY



K 420 adhesive



Marine sealant



Measurements



Actions

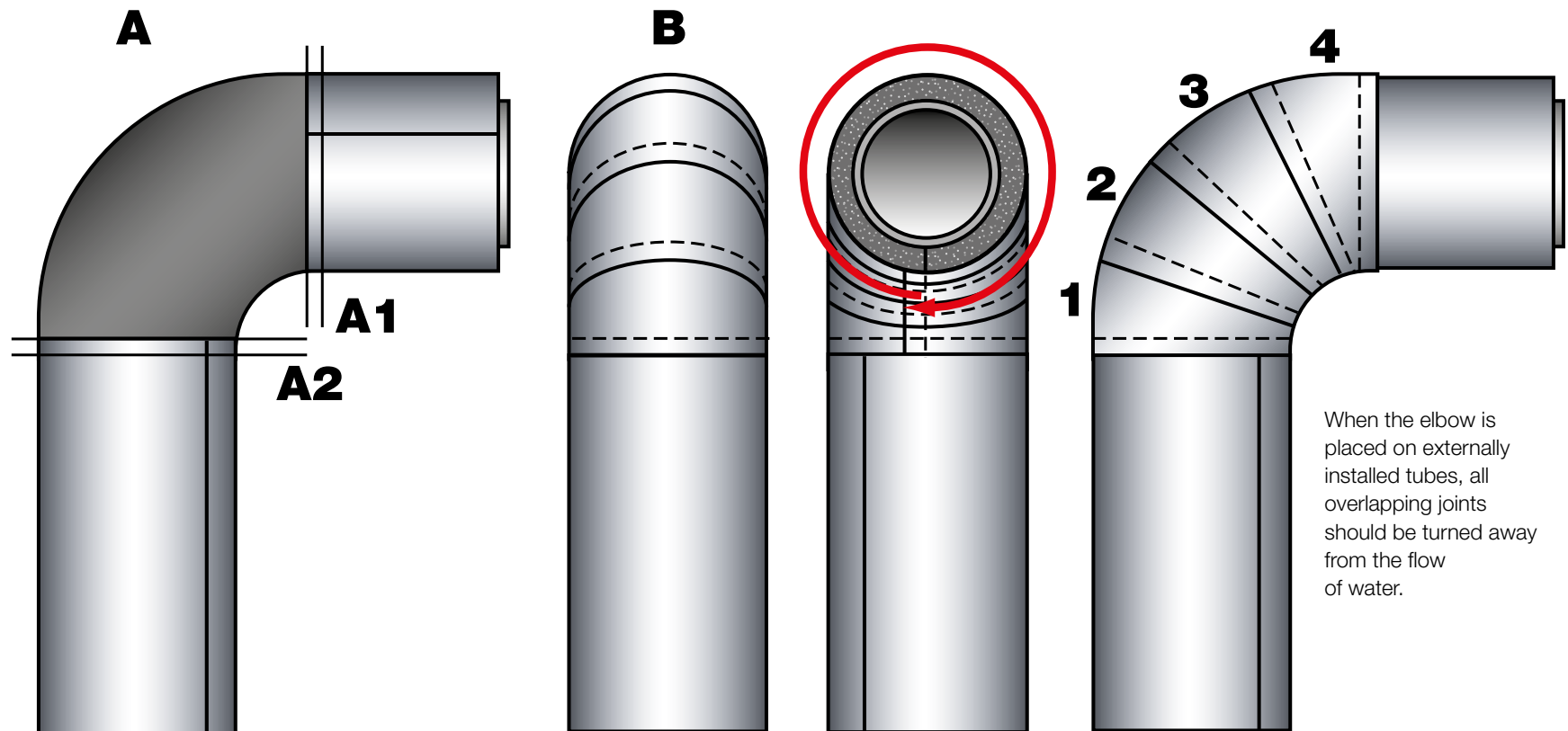

When the elbow is placed on externally installed tubes, all overlapping joints should be turned away from the flow of water.

MATERIALS



KEY



K 420 adhesive



Marine sealant



Measurements



Actions

K-FLEX® IN CLAD - ELBOWS

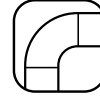

FINISHING OF ELBOWS WITH IN CLAD SHEET

Which shape to choose.

The longitudinal joints of the elbow can be carried out in three different ways, with the relevant overlapping:

- A)** EXTERNAL-DORSAL joint
- B)** INTERNAL-THROAT joint
- C)** SIDE joint

Each of the three elbow types require different shapes, obtainable from the appropriate template.

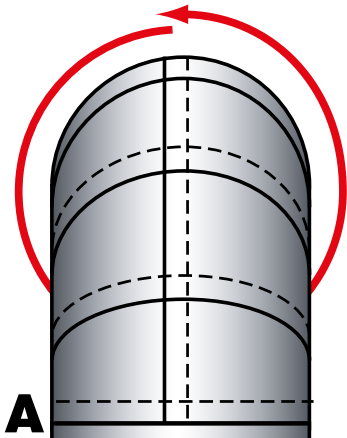

A

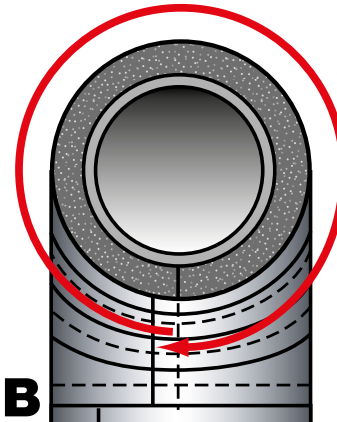
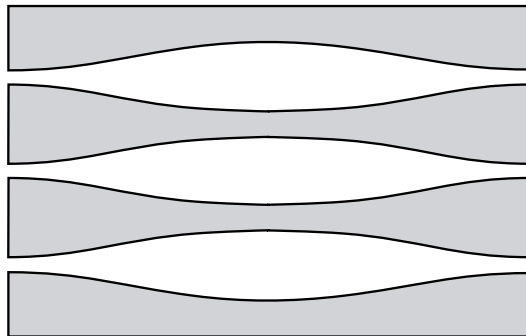

B

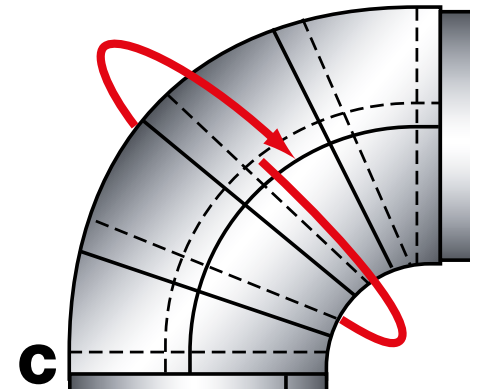
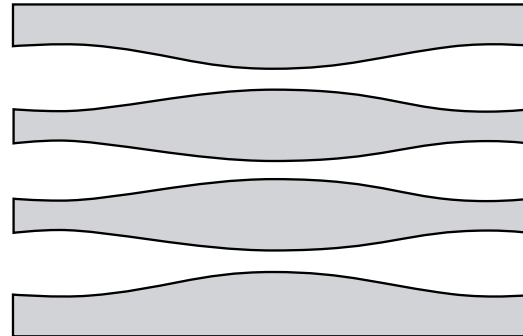

C

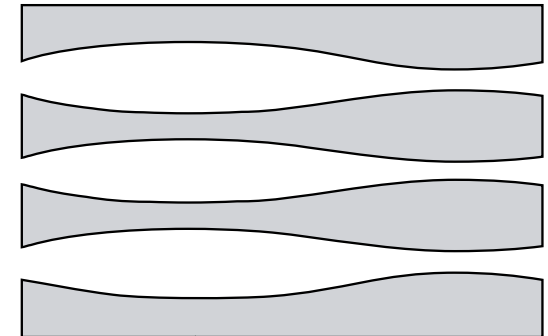

MATERIALS



KEY



K 420 adhesive

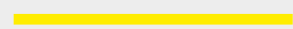

Marine sealant



Measurements



Actions

K-FLEX® IN CLAD - ELBOWS



FINISHING OF ELBOWS WITH IN CLAD SHEET

How to seal the joints of the IN CLAD elbows

Each shaped segment should be sealed around the insulated elbow, using the overlaps already prepared.

Applying K 420 adhesive on the joining edges, the overlaps of the elbow and on the head **(A-B-C)**,

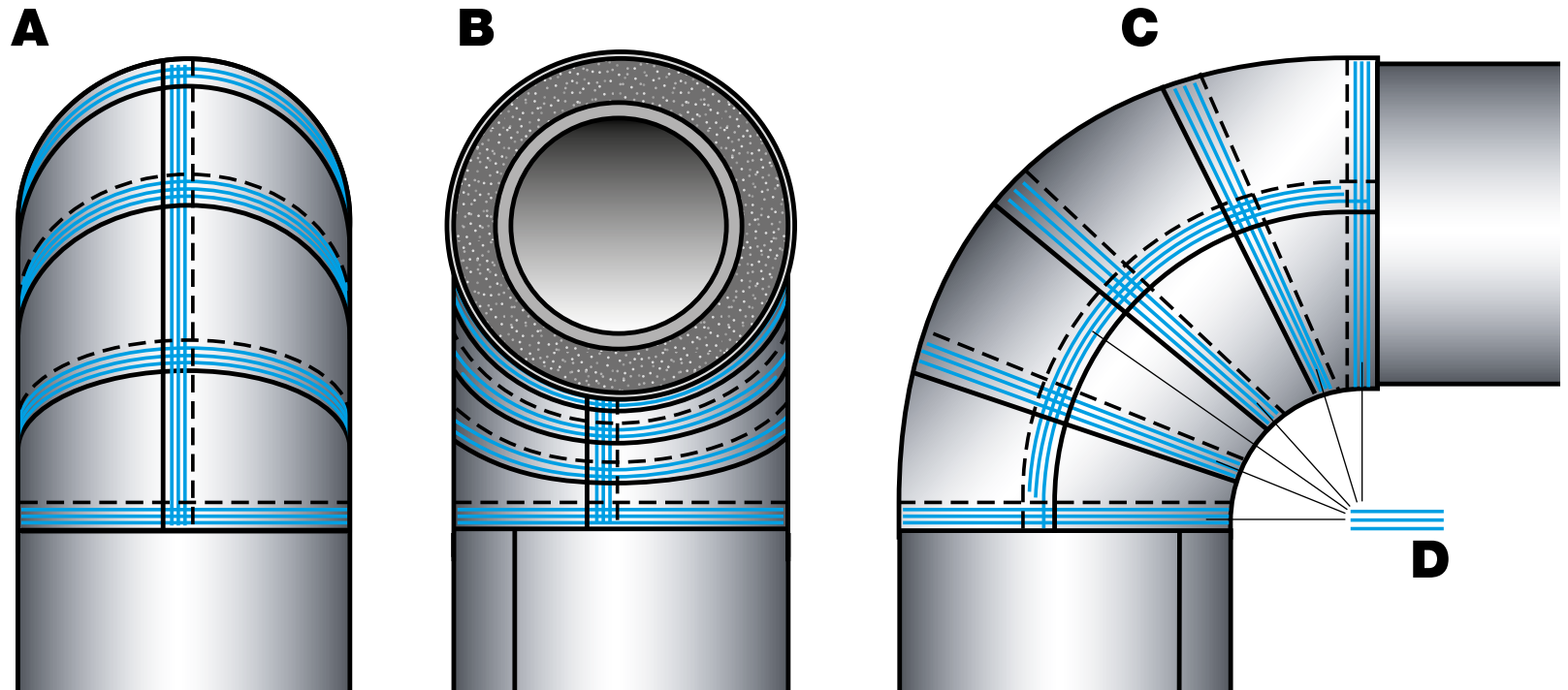

- A)** EXTERNAL-DORSAL joint
- B)** INTERNAL-THROAT joint
- C)** SIDE joint

MATERIALS



KEY



K 420 adhesive



Marine sealant



Measurements



Actions

K-FLEX® IN CLAD - ELBOWS



FINISHING OF ELBOWS WITH IN CLAD SHEET

Seal all the visible joints and edges of the tapes with marine sealant.
If necessary, seal the joints with the specific IN CLAD tape secured with glue.

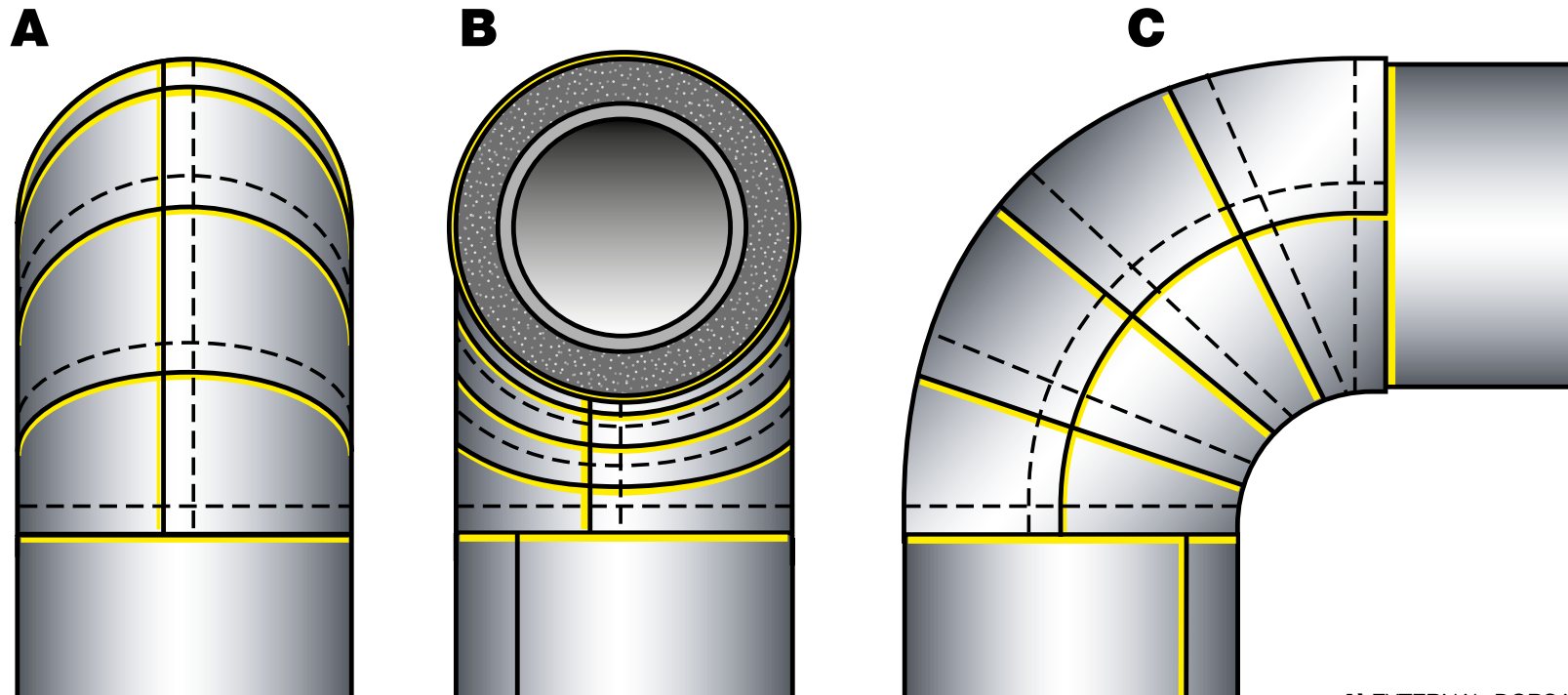

- A)** EXTERNAL-DORSAL joint
- B)** INTERNAL-THROAT joint
- C)** SIDE joint

MATERIALS

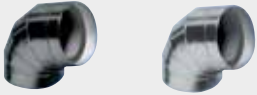

KEY



K 420 adhesive



Marine sealant

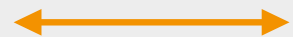

Measurements



Actions

K-FLEX® IN CLAD - ELBOWS

INSTALLATION OF PRE-SHAPED K-FLEX® IN CLAD ELBOWS

The IN CLAD pre-shaped elbows have the IN CLAD covering sheet applied in segments. They are all cut on the underside with an abundance to allow for overlapping of the covering sheet. They also have an overlap for the closure on the ends.

INSTALLATION:

A-B) After having laid the tubes, install the pre-shaped IN CLAD elbow.

C) Glue the elastomer edges with K 420 (the detail in **C1**)

D) Close the elastomer edges.

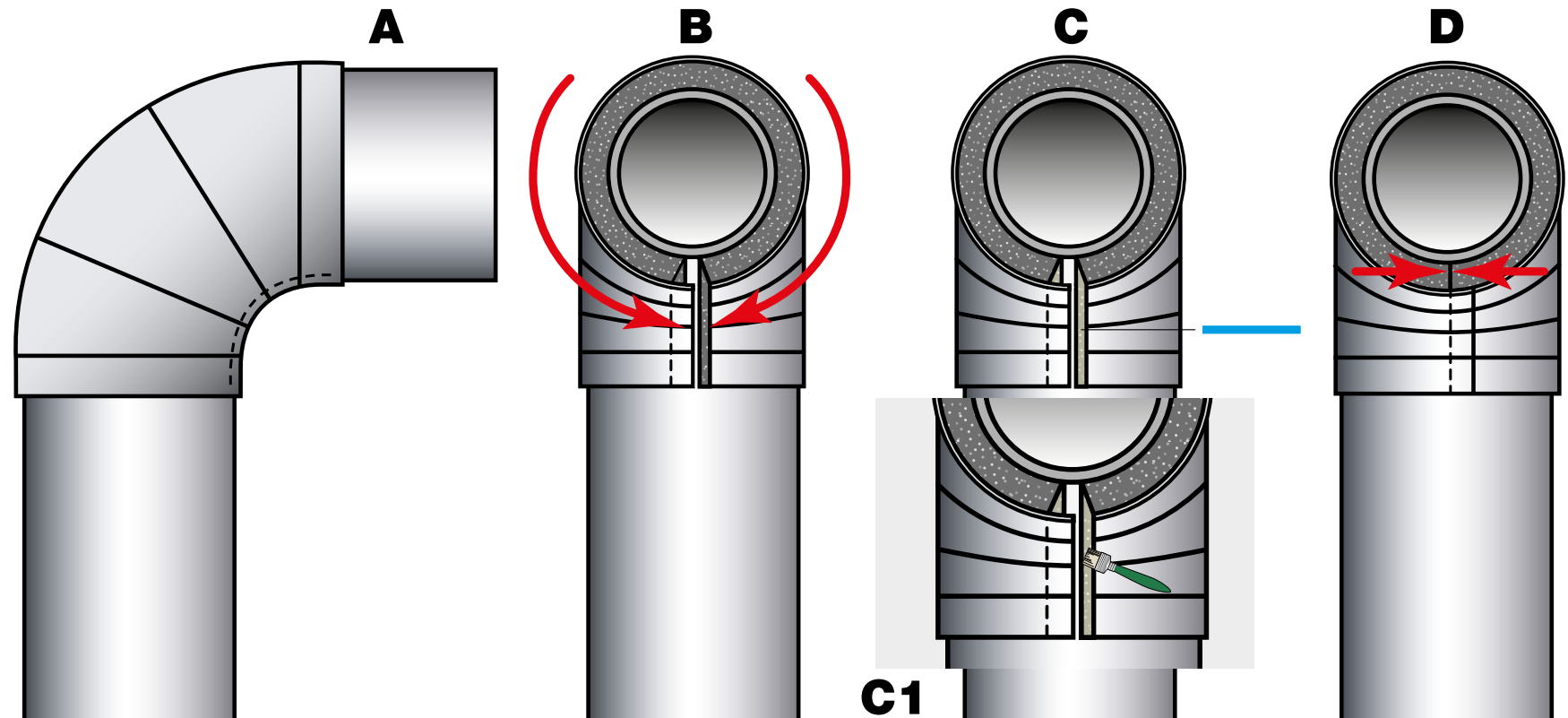

MATERIALS

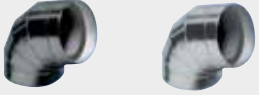

KEY



K 420 adhesive



Marine sealant



Measurements



Actions

K-FLEX® IN CLAD - ELBOWS

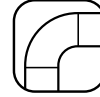

INSTALLATION OF PRE-SHAPED K-FLEX® IN CLAD ELBOWS

- A)** Glue the parts.
- B)** Seal the throat, segment and end overlaps onto the tubes.
- B1)** The illustration shows a detail of how the throat overlap should be sealed: in **B2** the overlap is sealed with glue.
- D)** Seal all visible joints with marine sealant. If necessary, seal the joints with the specific IN CLAD tape secured with glue.

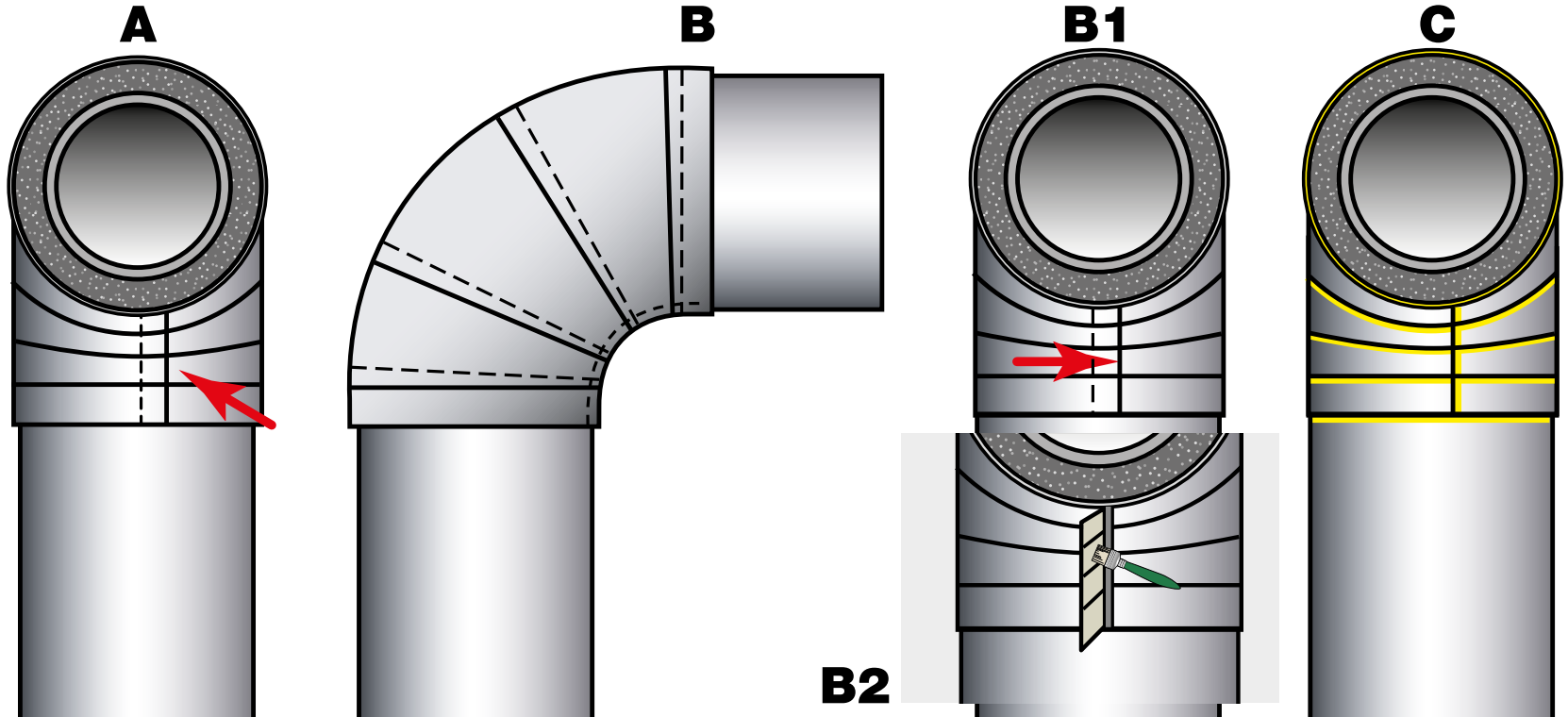

K-FLEX® IN CLAD “T-PIECES”

In the application sequence the finishing is represented. The indications are also the same for the use of **IN CLAD IB (Black)** finishing.



For the application procedures of K-FLEX® insulating prepared by the installer with sheet sections, see the relevant sections of the K-FLEX® APPLICATION GUIDE

If you are not in possession of a printed guide you can ask for it at our technical dept. or download the PDF file from our website: www.kflex.com

MATERIALS



KEY



K 420 adhesive



Marine sealant



Measurements



Actions

K-FLEX® IN CLAD - "T-PIECE"



FINISHING OF "T-PIECE" WITH IN CLAD SHEET

Which shape to choose

The application of the K-FLEX® IN CLAD sheet on the "T-piece" sections requires the use of appropriate template to fit the shape of the connections. The templates are available in standard dimensions of two specific types:

- A)** Template for connection with equal diameters.
- B)** Template for connection with different diameters.

A

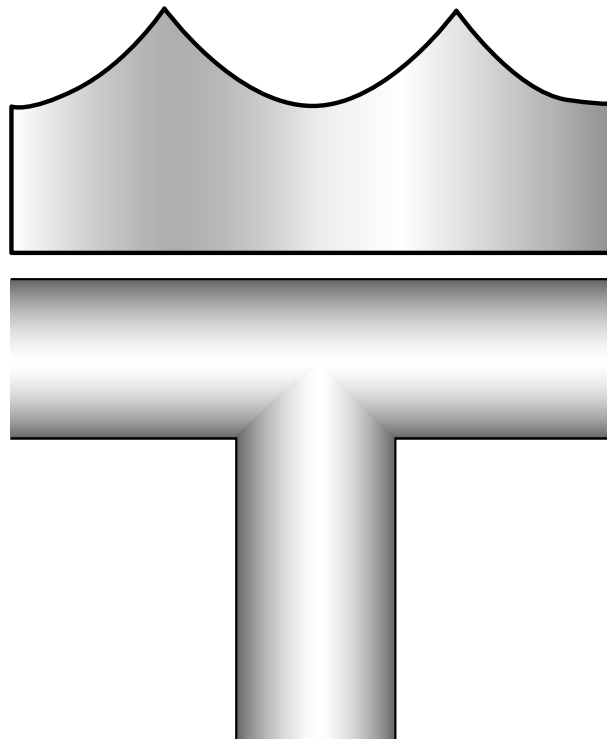

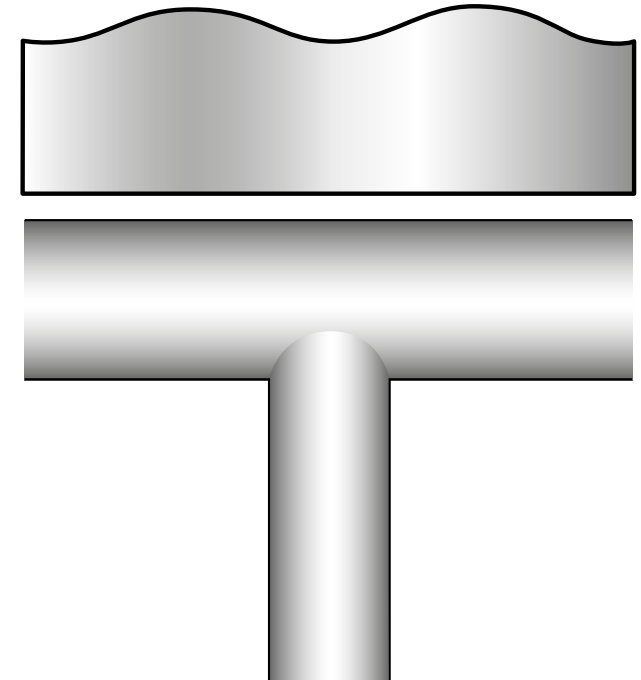

B



MATERIALS

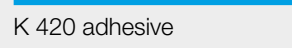
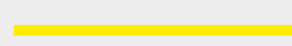

KEY

-  abundance
-  K 420 adhesive
-  Marine sealant
-  Measurements
-  Actions

K-FLEX® IN CLAD - "T-PIECE"



FINISHING OF "T-PIECE" WITH IN CLAD SHEET

A)

From a K-FLEX® IN CLAD sheet, cut a section out with the same dimensions as that of the surface of the insulated tube, leaving an abundance for the overlap.

B)

Place the shape around the connecting pipe. The indentation should open up around the "T-piece".

Glue the overlap and seal the longitudinal edges of the sheet.

With the same adhesive also glue the indentations onto the connecting tube.

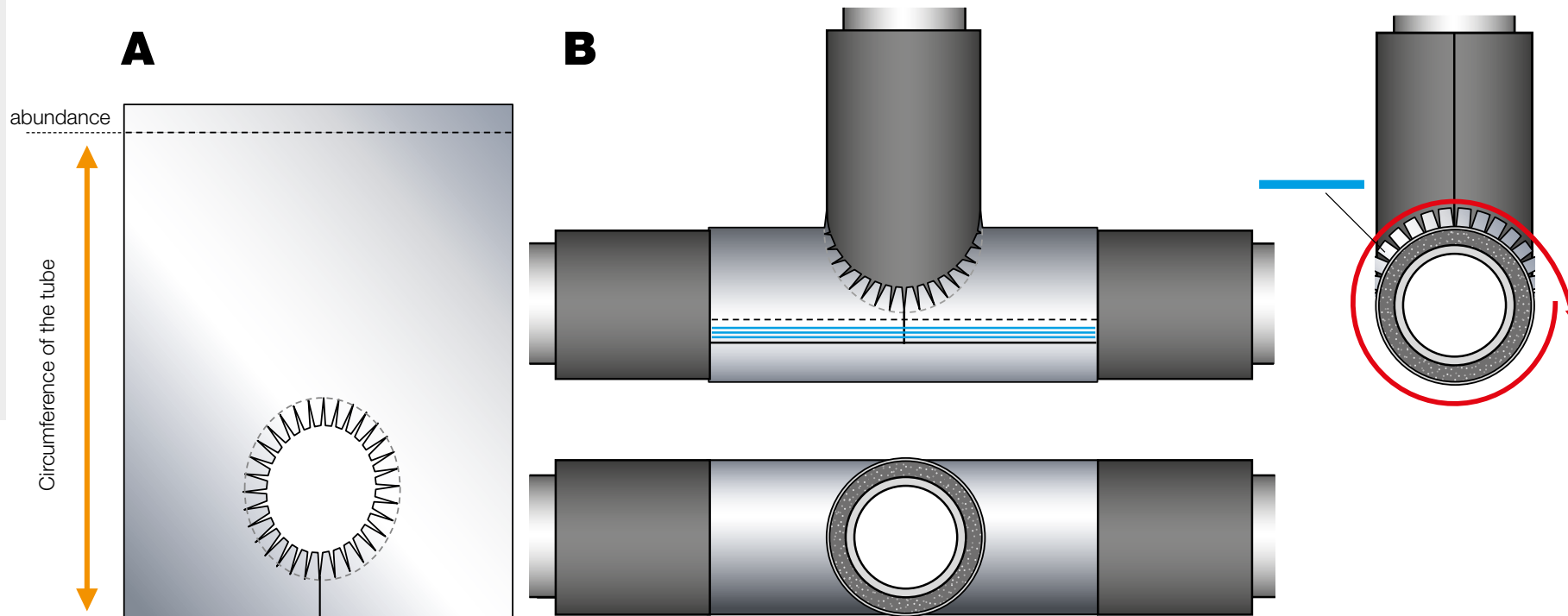

MATERIALS



KEY



K 420 adhesive

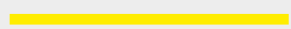

Marine sealant



Measurements



Actions

K-FLEX® IN CLAD - "T-PIECE"



"T-PIECE" FINISHING WITH THE CONNECTION PLACED OVER THE TUBE - TYPE 1, WITH SIDE JOINT TEMPLATE.

A)

Using the appropriate template, draw the shape of the connection on a section of specific K-FLEX® IN CLAD sheet leaving an excess of 5 cm for the overlap.

B)

Cut out the shape.

C)

Place the shape around the section of the connecting pipe. Glue the overlap and seal the longitudinal edges of the sheet.

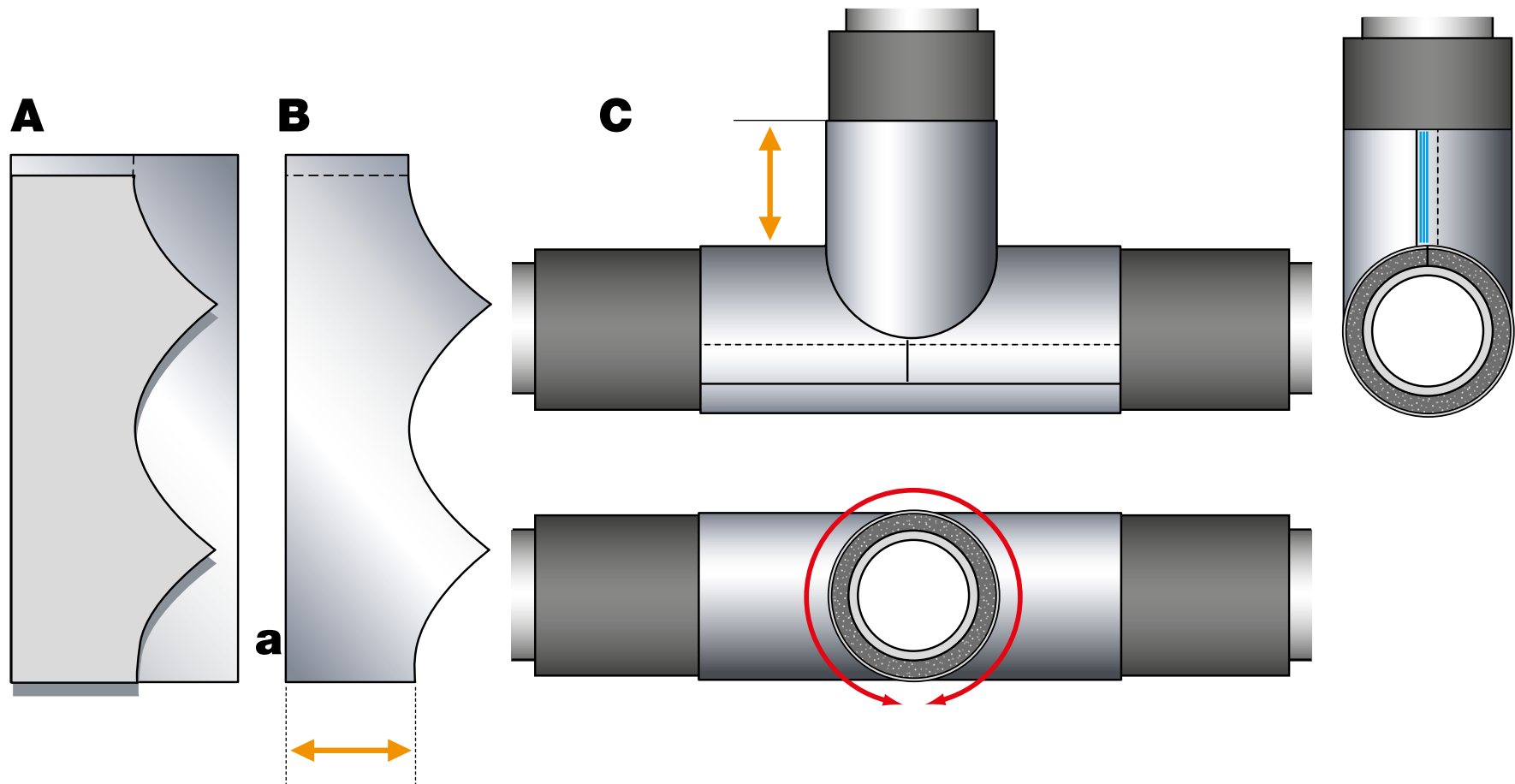

MATERIALS



KEY



K 420 adhesive



Marine sealant

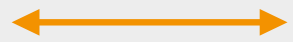

Measurements



Actions

K-FLEX® IN CLAD - "T-PIECE"



"T-PIECE" FINISHING WITH THE CONNECTION PLACED OVER THE TUBE - TYPE NO. 2, WITH FRONT JOINT TEMPLATE.

A)

Using the appropriate template, draw out the shape of the connection on a section of K-FLEX® IN CLAD sheet leaving an excess of at least 5 cm for the overlap.

B)

Cut out the shape.

C)

Place the shape around the section of the connecting pipe. Glue the overlap and seal the longitudinal edges of the sheet.

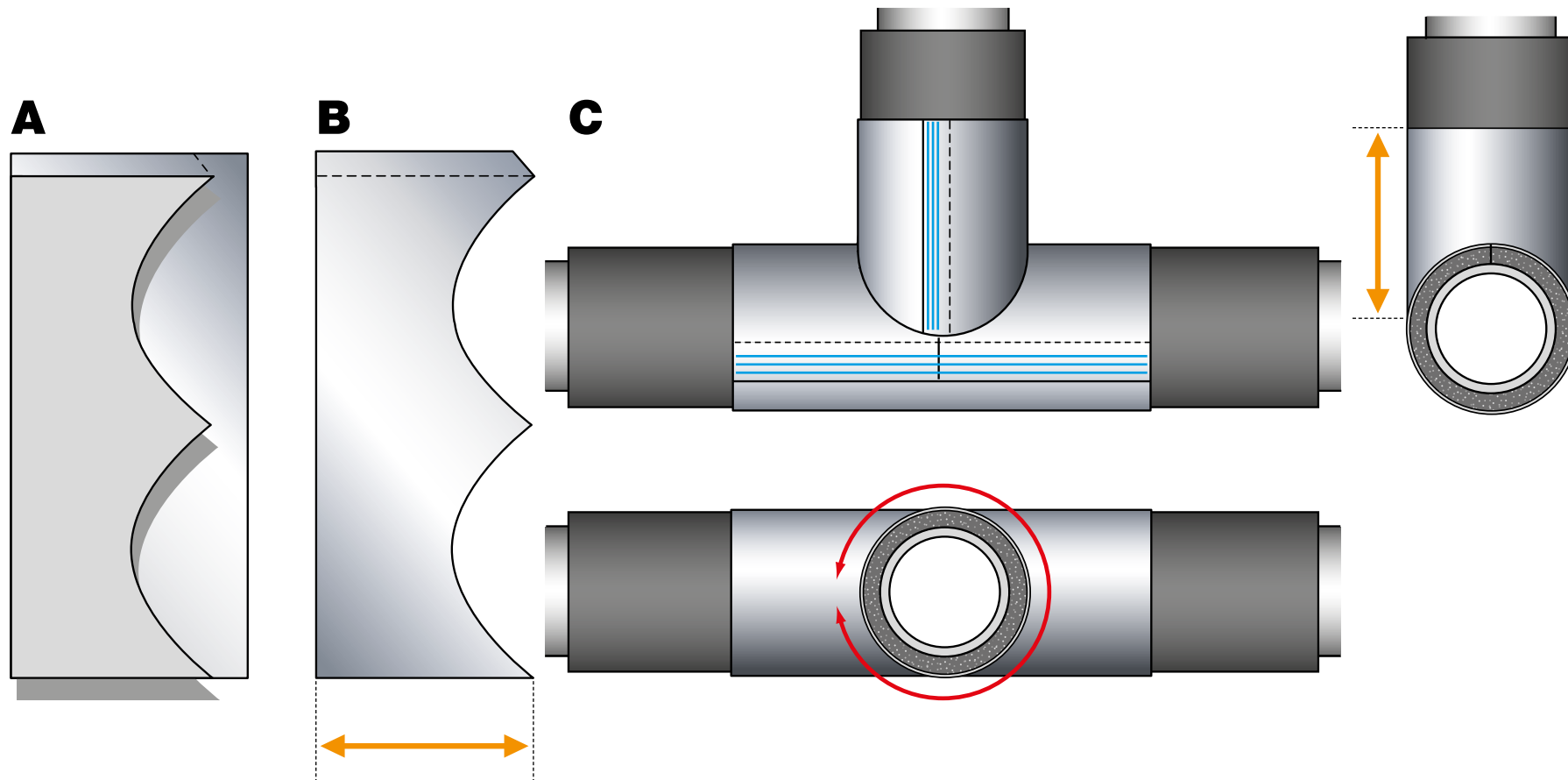

MATERIALS



KEY



K 420 adhesive



Marine sealant



Measurements



Actions

K-FLEX® IN CLAD - "T-PIECE"

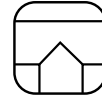

"T-PIECE" COVERING WITH THE CONNECTION PLACED UNDER THE TUBE

A) On a section of K-FLEX® IN CLAD sheet, using the correct template, draw the shape of the connection, plus an abundance of at least 5 cm for the overlap. Along the curves, form the indentation.

B) Cut out the segment.

C) Place the shape around the section of the connecting pipe. The perforation should open up on the connection. Glue the overlap and seal the longitudinal edges of the sheet. With the same adhesive also glue the indentations around the connection

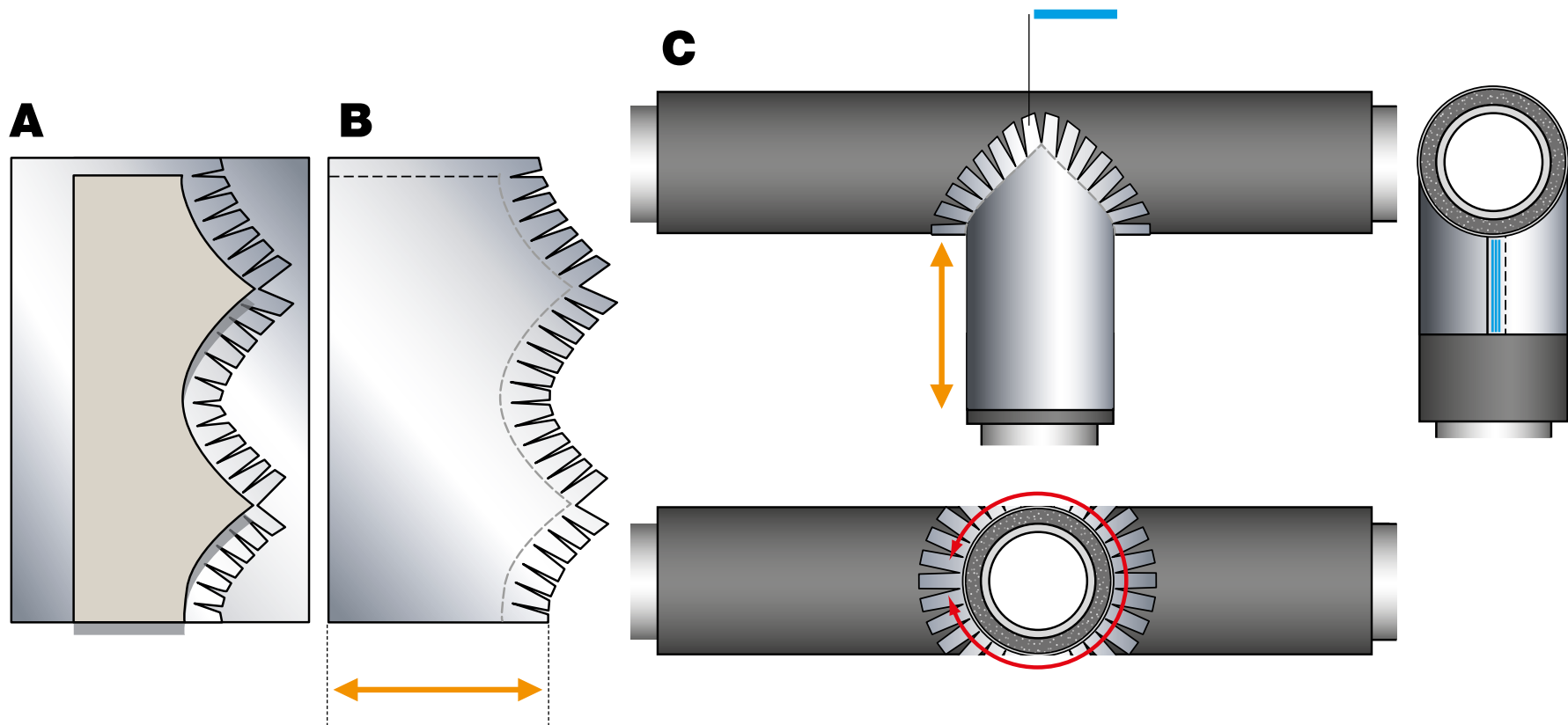

MATERIALS



KEY



K 420 adhesive

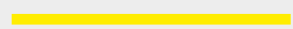

Marine sealant



Measurements



Actions

K-FLEX® IN CLAD - "T-PIECE"



"T-PIECE" COVERING WITH THE CONNECTION PLACED UNDER THE TUBE

A) Draw the shape of the connection on a section of K-FLEX® IN CLAD sheet **a)** with the same dimensions as the insulated tube, plus an abundance for the overlap. Cut out the segment.

B) Place the segment around the section of the connecting pipe, overlapping it on the previously placed indentations. Glue the overlap and seal the longitudinal edges of the sheet **b)**.

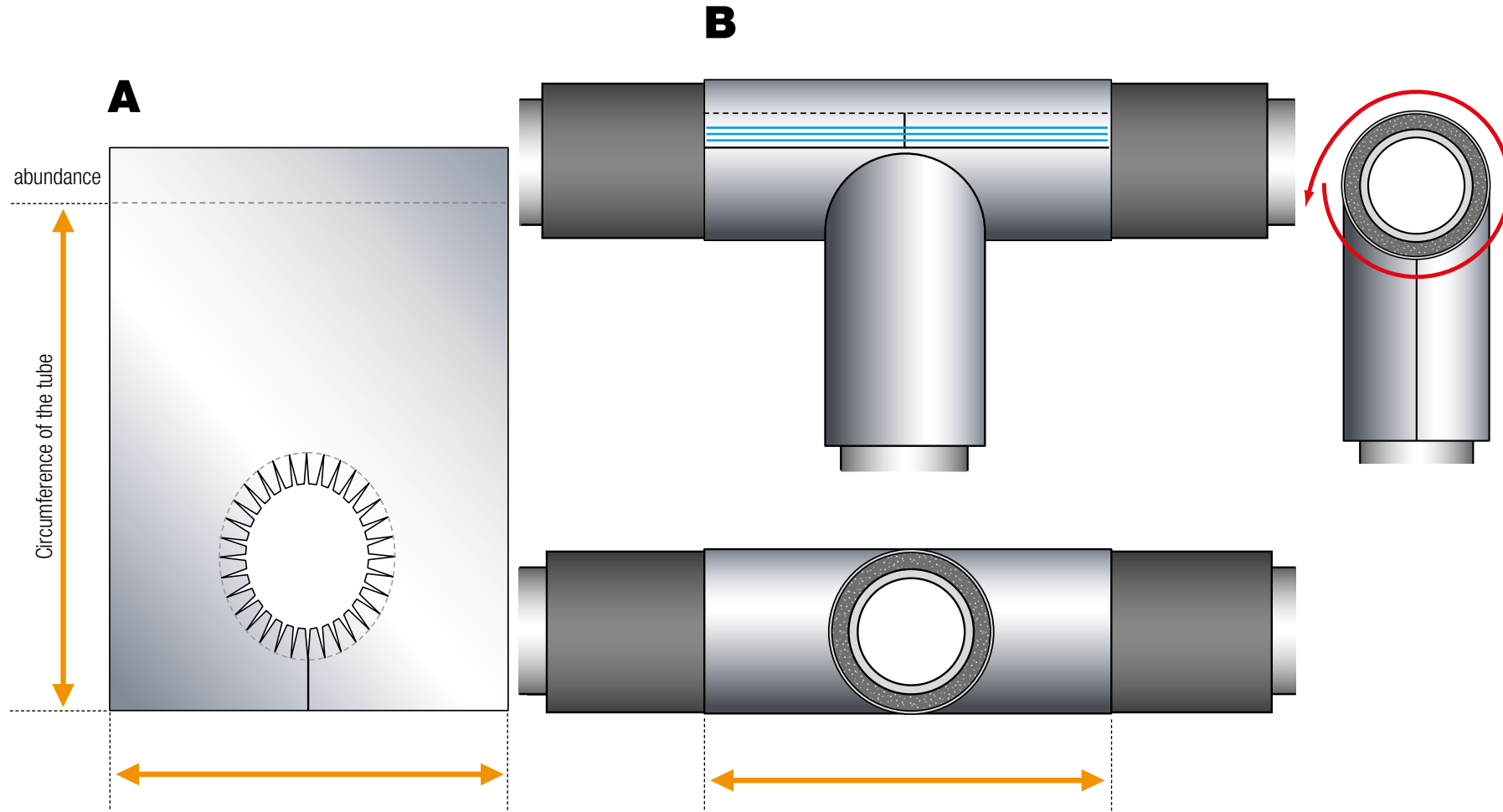

MATERIALS



KEY

- K 420 adhesive
- Marine sealant
- Measurements
- Actions

K-FLEX® IN CLAD - "T-PIECE"

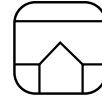

"T-PIECE" COVERING: SEALING OF THE JOINTS

If necessary, seal the joints with the specific IN CLAD tape secured with glue.
Seal the joints and the edges of the tape with marine sealant

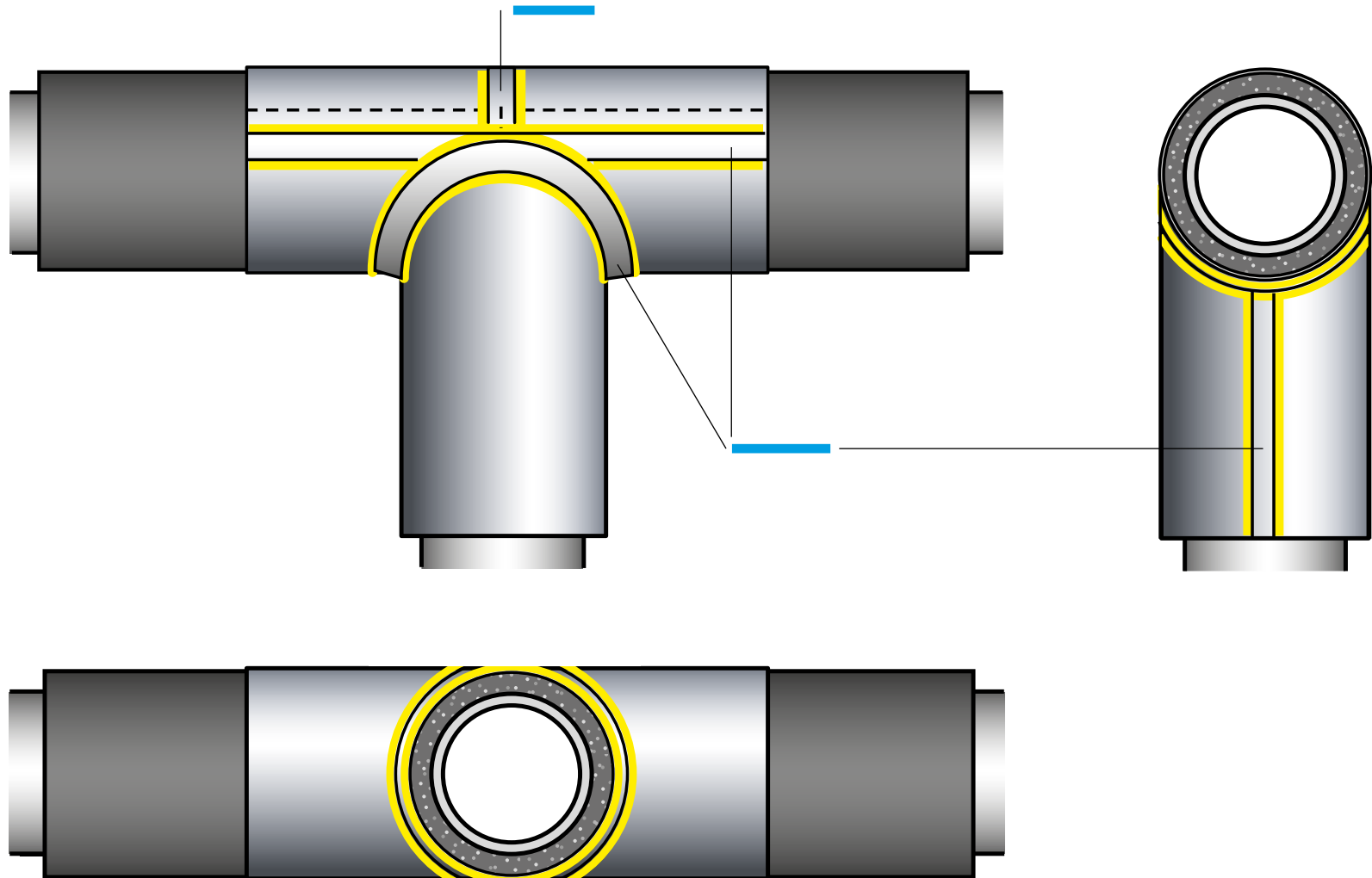

MATERIALS



KEY



K 420 adhesive



Marine sealant



Measurements



Actions

K-FLEX® IN CLAD - "T-PIECE"



INSTALLATION OF "T-PIECES" WITH IN CLAD SYSTEM

The pre-shaped and pre-cut "T-pieces", have the IN CLAD sheet already applied. They also have a longitudinal cut complete with an overlap for sealing the covering. They also include an overlap for sealing the ends together.

INSTALLATION

A) Install the 3 adjacent tubes, leaving sufficient space to attach the "T-piece".

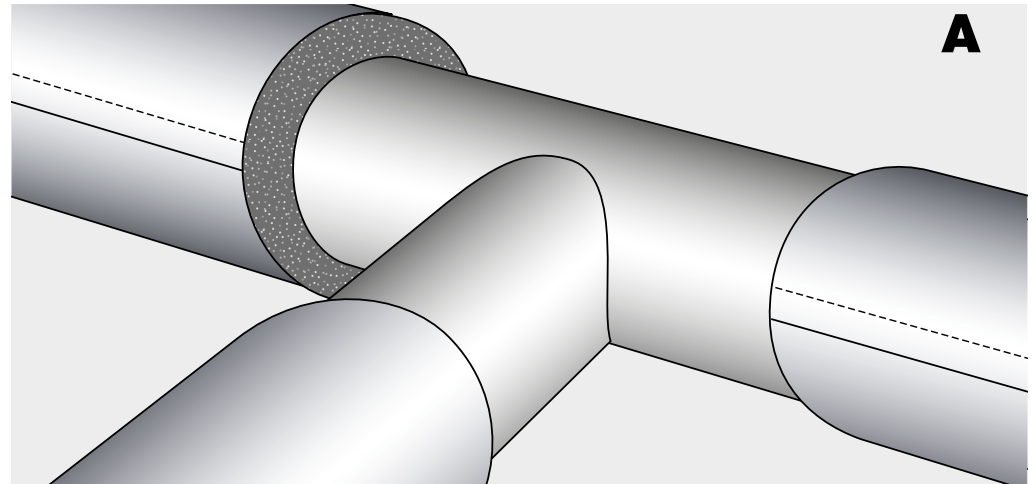

B) If you want to make "V" shaped cuts in the covering of the end overlaps, to help adhesion with the ends of the tubes, this operation should be carried out before installing the "T-piece" and before applying adhesive to the elastomeric sections.

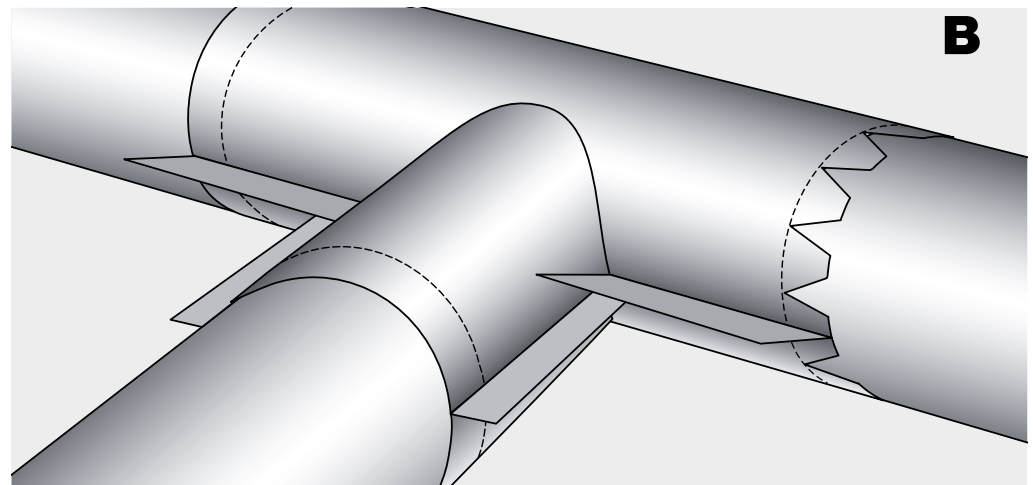

MATERIALS



KEY



K 420 adhesive

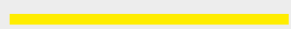

Marine sealant



Measurements



Actions

K-FLEX® IN CLAD - "T-PIECE"

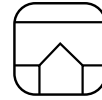

INSTALLATION OF "T-PIECES" WITH IN CLAD SYSTEM

INSTALLATION

- C)** Glue the ends of the tubes with K 420.
- D)** Glue the elastomeric ends of the "T-piece".
- E)** Attach the K-FLEX® IN CLAD "T-piece" placing the end overlaps of the "T-piece" over the ends of the three tubes already installed.

Seal the elastomeric ends of the "T-piece" with those of the tubes.

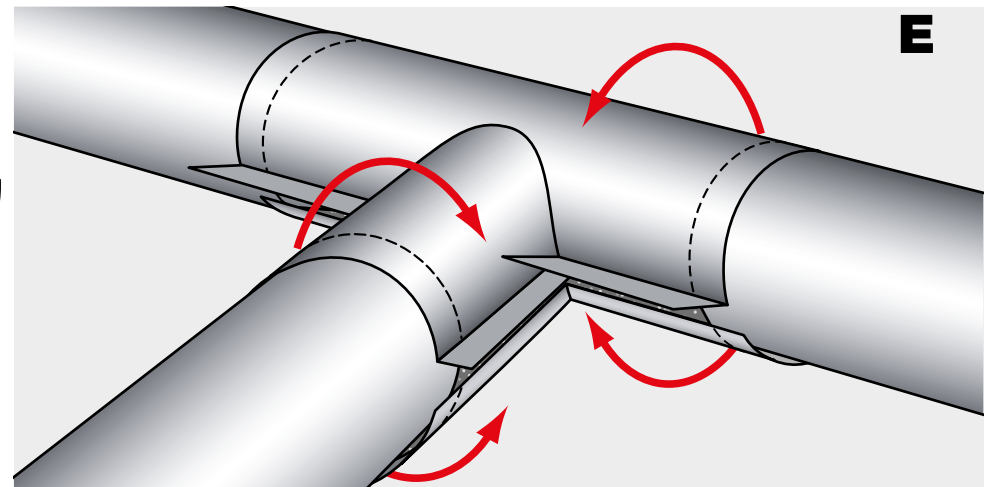
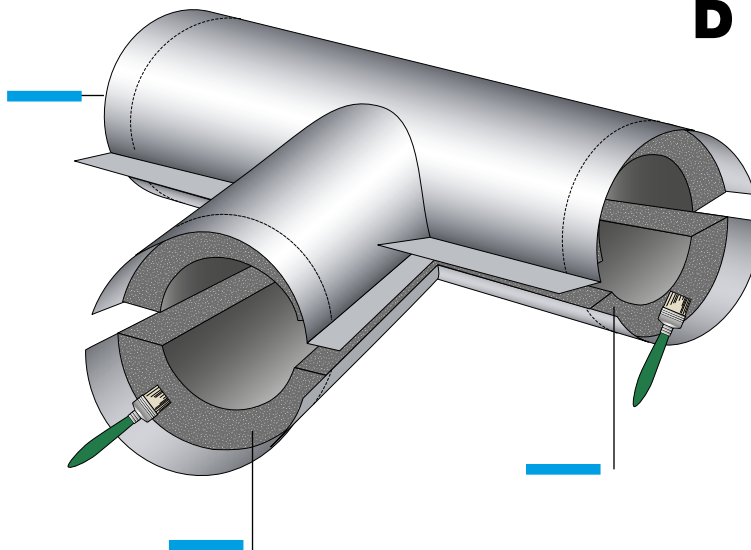
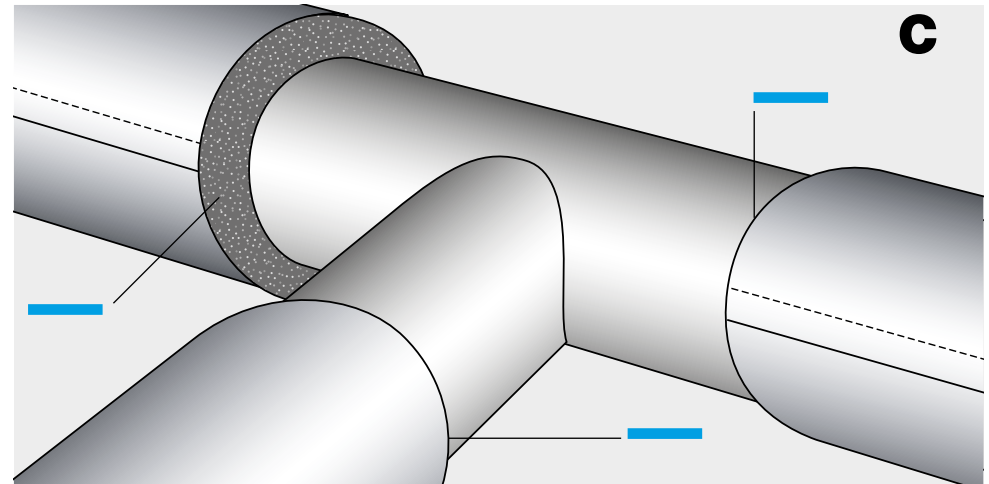

MATERIALS



KEY



K 420 adhesive

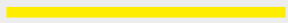

Marine sealant

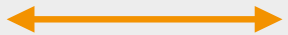

Measurements



Actions

K-FLEX® IN CLAD - "T-PIECE"



INSTALLATION OF "T-PIECES" WITH IN CLAD SYSTEM

F) Glue the borders of the elastomer with K 420 adhesive.

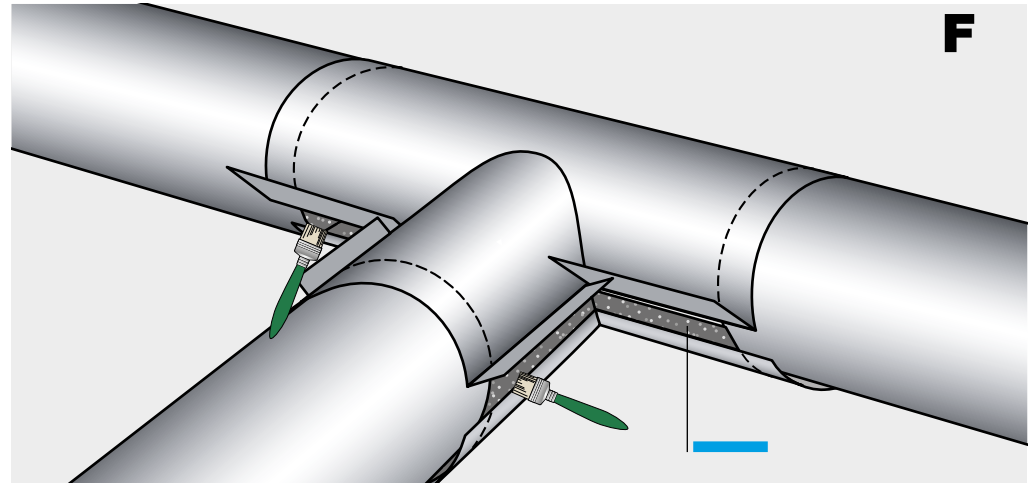

G) Seal the edges.

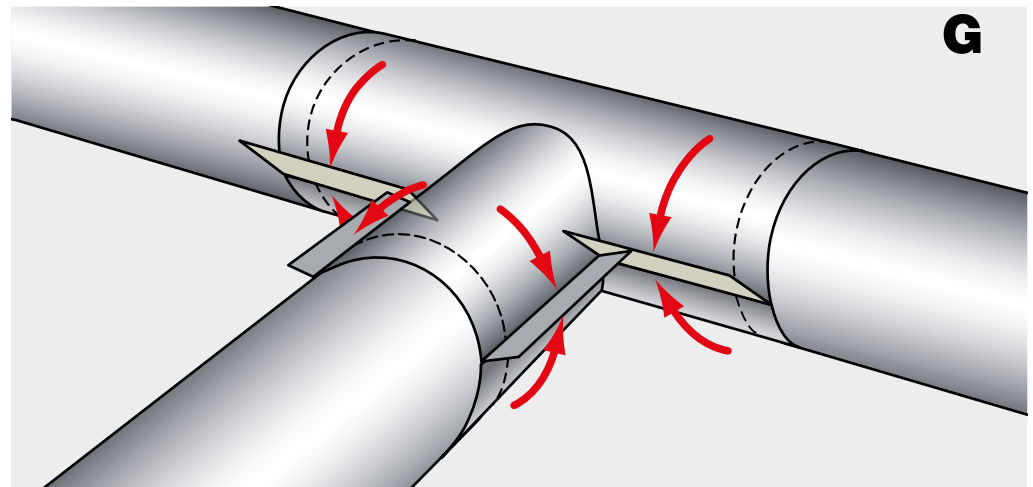

MATERIALS

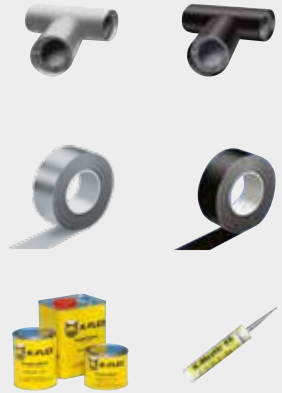

KEY



K 420 adhesive

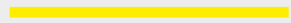

Marine sealant

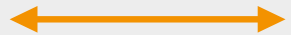

Measurements



Actions

K-FLEX® IN CLAD - "T-PIECE"

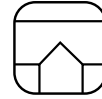

INSTALLATION OF "T-PIECES" WITH IN CLAD SYSTEM

H) Seal all joints with marine sealant. If necessary, seal the joints with the specific IN CLAD tape secured with glue.

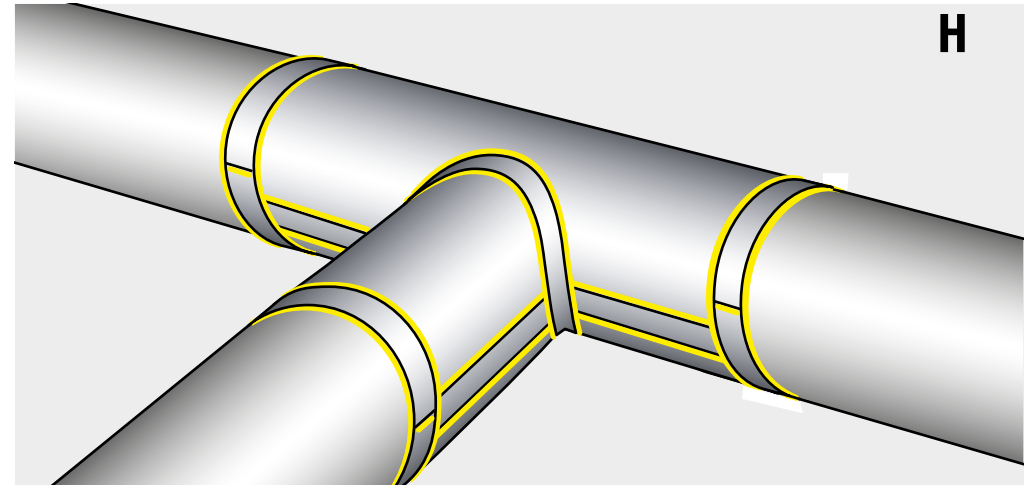

K-FLEX® IN CLAD FLANGES

In the application sequence the **IN CLAD IG (Grey)** finishing is represented. The indications are also the same for the use of **IN CLAD IB (Black)** finishing.



For the application procedures of K-FLEX® insulating prepared by the installer with sheet sections, see the relevant sections of the K-FLEX® APPLICATION GUIDE

If you are not in possession of a printed guide you can ask for it at our technical dept. or download the PDF file from our website: www.kflex.com

MATERIALS



KEY



K 420 adhesive



Marine sealant



Measurements



Actions

K-FLEX® IN CLAD - FLANGES

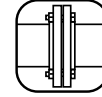

INSTALLATION OF FLANGES WITH IN CLAD COVERING

Covering of adjacent tubes

Prepare two IN CLAD sheet sections (**a-b**) of a width corresponding to the surface of the adjacent insulated tubes, plus the correct abundances of 5 cm for the overlap, and cut out the indentation on the side which comes into contact with the flange.

Wrap the two sections around the insulated tubes resting the indentation against the flange disks, in order to obtain perfect adhesion.

With the correct adhesive, glue the longitudinal overlap (**c**) and the indentation which is in contact with the flange (**d**), away from the flow of water.

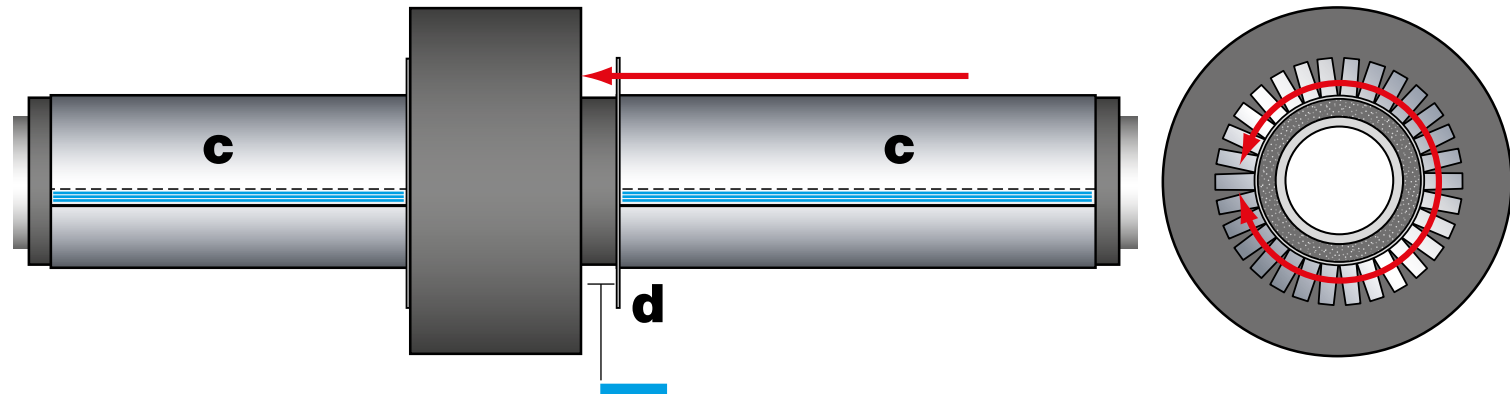
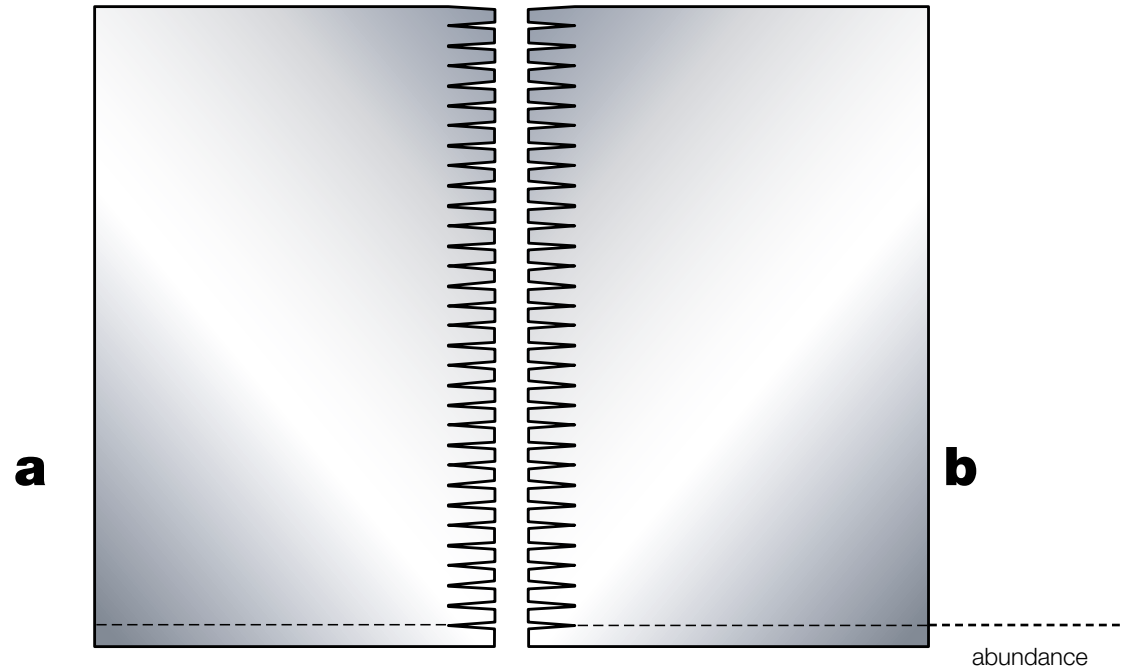

MATERIALS



KEY



K 420 adhesive



Marine sealant



Measurements



Actions

K-FLEX® IN CLAD - FLANGES

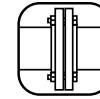

COVERING OF FLANGES INSTALLED ON HORIZONTAL PIPES

Covering of the lateral disks

A) Prepare two equal sections of IN CLAD sheet and on each one trace an indentated ring of a diameter corresponding to the disks of the flange **a)**. The diameter **b)** defines the limit of the external profile of the indentations. The diameter of the hole **c)** corresponds to that of the pipe already covered on which the indentated ring should be installed. The tracing should include a cut **d)** for easy installation of the rings on the respective tube.

B) After having cut out the shape of each ring, place it on the respective pipe so that it adheres to the disk of the flange and covers the indentation of the sheet previously installed on the tube.

C) On parts which come into contact with the flange, seal the disk with the correct glue all along the circumferences and where cuts have been made.

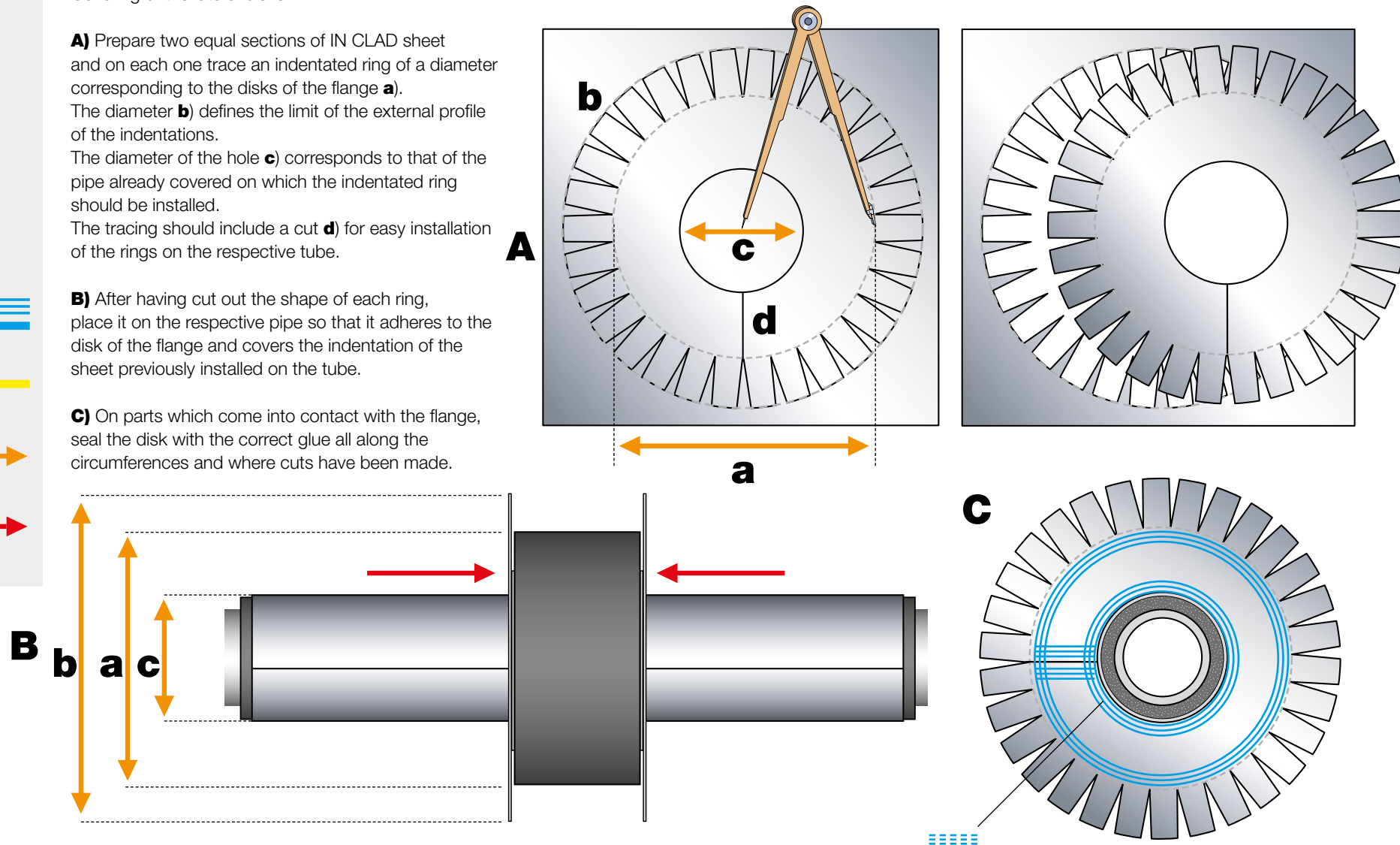

MATERIALS



KEY



K 420 adhesive

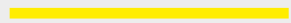

Marine sealant



Measurements



Actions

K-FLEX® IN CLAD - FLANGES

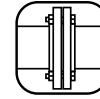

COVERING OF FLANGES INSTALLED ON HORIZONTAL PIPES

Covering of the flange body

A) Glue the indentations with the correct adhesive, bend them along the circumference and seal them on the body of the flange

B) Cut a section of K-FLEX® IN CLAD sheet of a dimension calculated to cover the external part of the valve's body, covering the indentations.

The covering sheet should have an excess to serve as the overlap (**b1**).

Apply the sheet section around the valve's body with the overlapping edge turned against the flow of water. Glue the joints with the correct adhesive (**b2**).



A

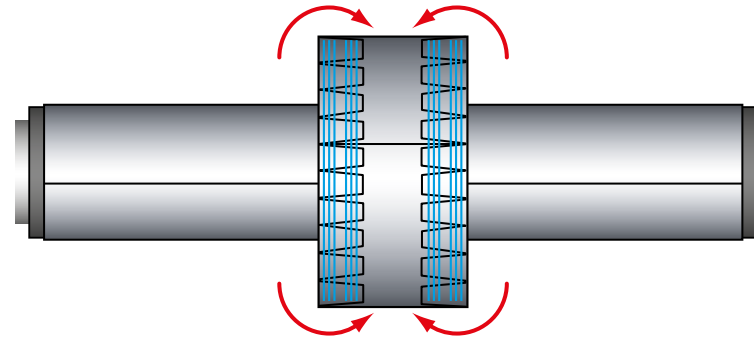

a1

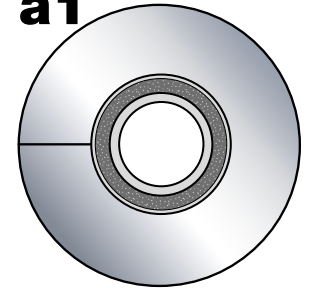

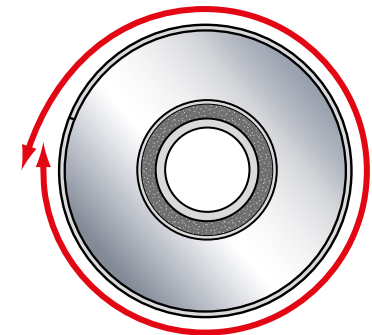
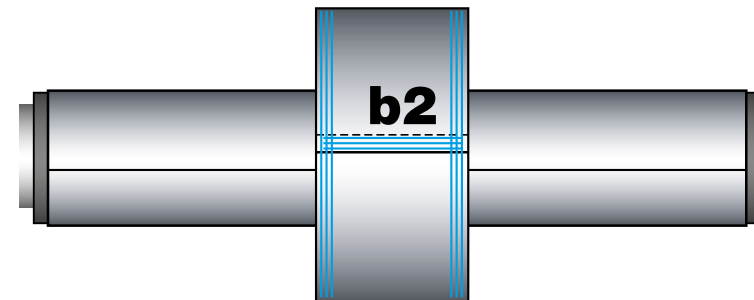

B



MATERIALS

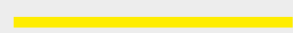

KEY

-  K 420 adhesive
-  Marine sealant
-  Measurements
-  Actions

K-FLEX® IN CLAD - FLANGES

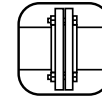

COVERING OF FLANGES INSTALLED ON HORIZONTAL PIPES

Covering of the flange body

A) If necessary, seal the joints with the specific IN CLAD tape secured with glue.

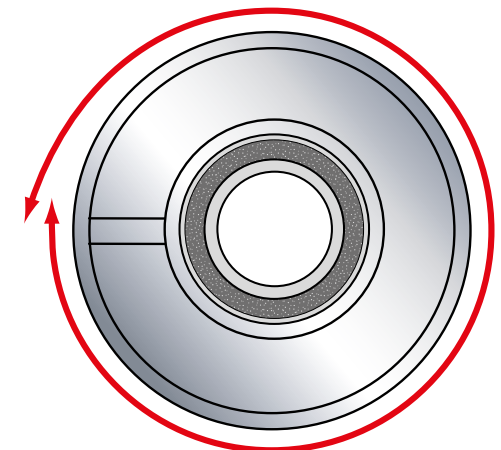
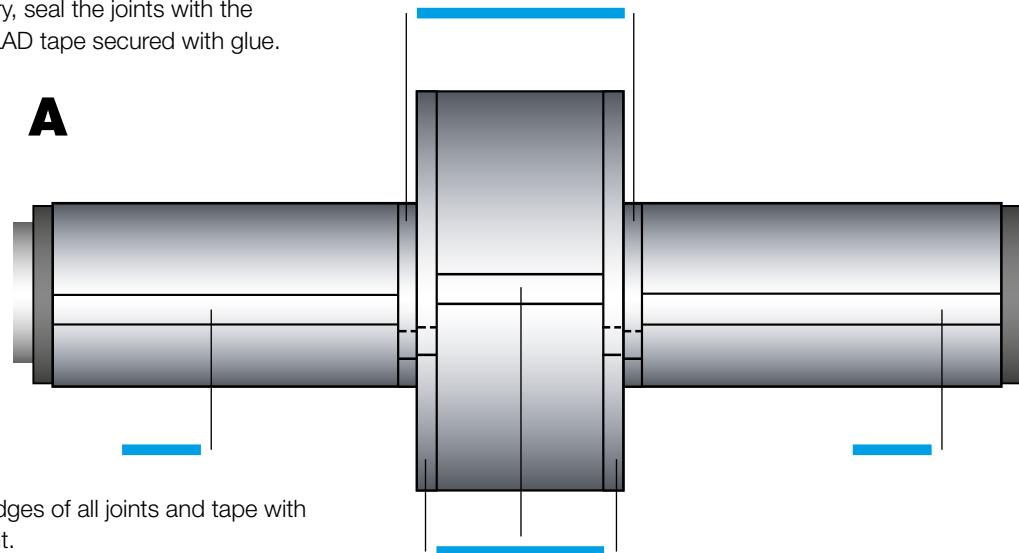

B) Seal the edges of all joints and tape with marine sealant.

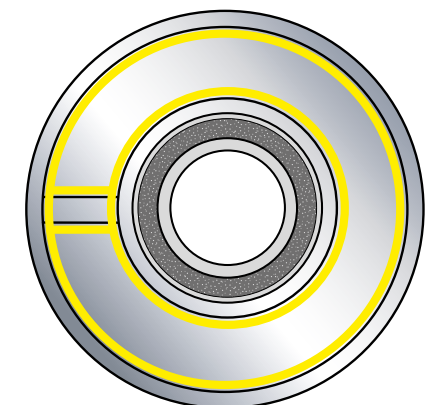
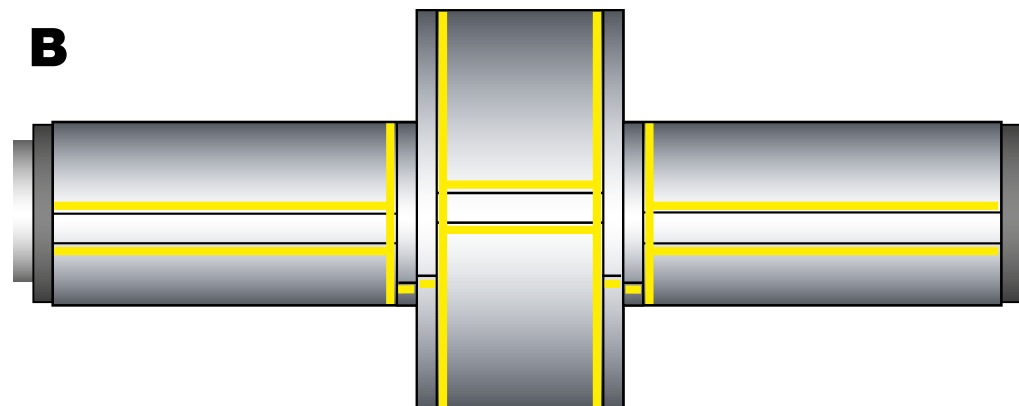

MATERIALS



KEY



K 420 adhesive



Marine sealant

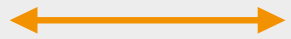

Measurements



Actions

K-FLEX® IN CLAD - FLANGES

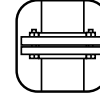

COVERING OF FLANGES INSTALLED ON VERTICAL PIPES

A) Cut a section of K-FLEX® IN CLAD sheet of a length corresponding to the surface of the insulated tube plus 5 cm of excess to overlap the joining edges.

B) Apply the indented sheet on the lower section of the pipe and glue the joining edges with the appropriate adhesive. The indentation should open up on contact with the lower disk of the flange **b1**).

C) Cut out an indented ring and apply it to the lower pipe close to the flange disk, in a way that it closes the indentation of the sheet previously installed on the tube.

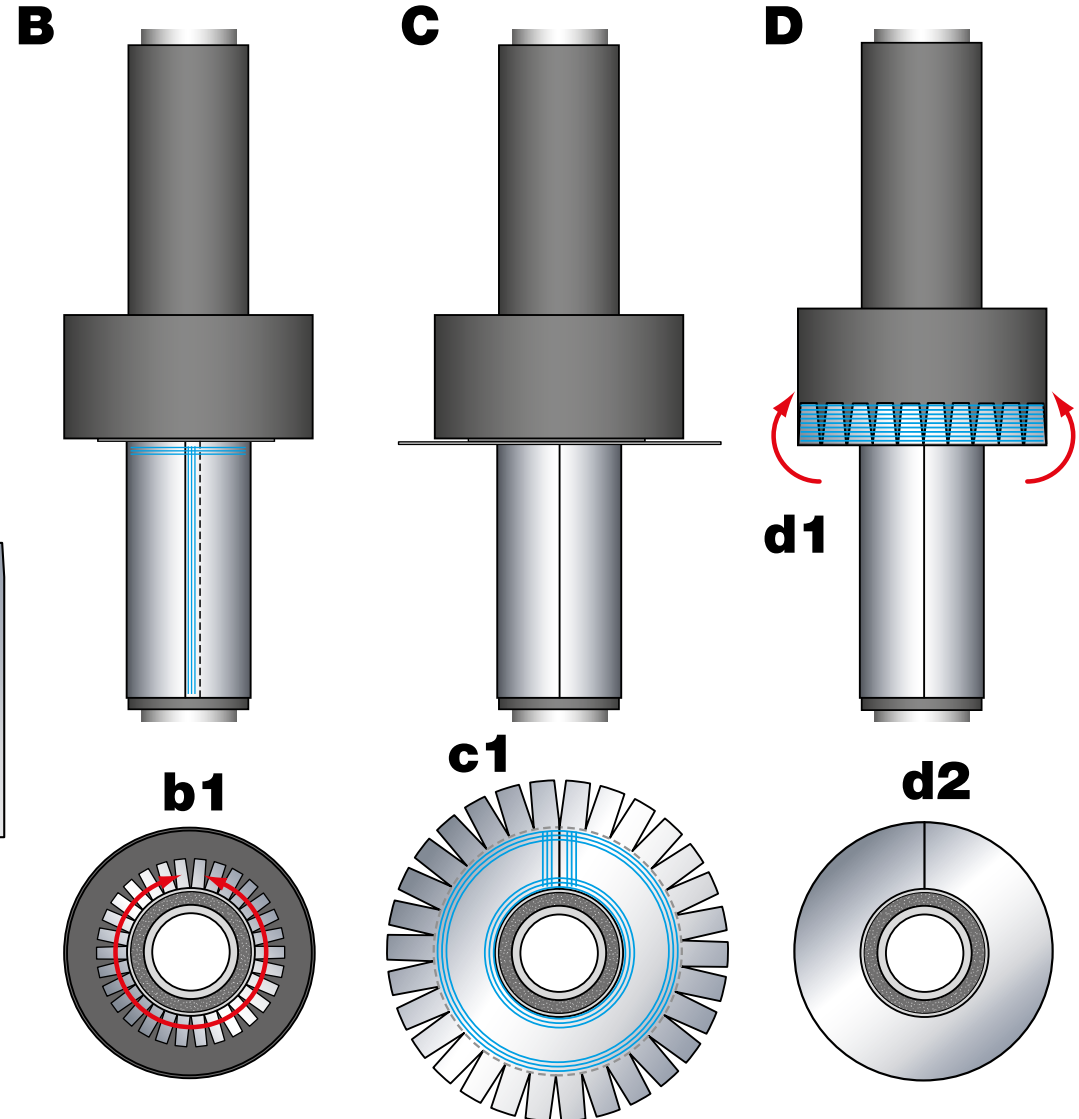
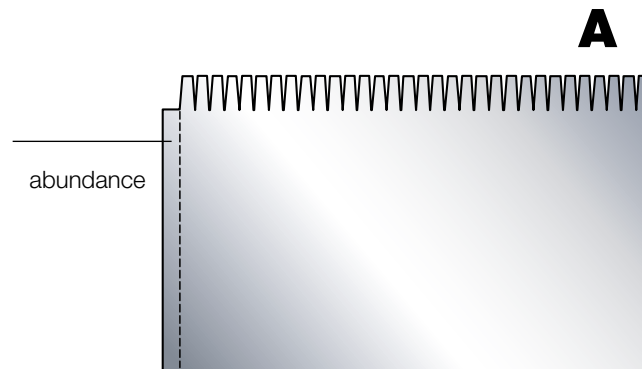

On parts which come into contact with the flange, seal the disk with adhesive along the circumference and where cuts have been made **(c1)**.

D) Glue the indentations of the ring and bend them onto the body of the flange **(d1 - d2)**.

MATERIALS



KEY



K 420 adhesive



Marine sealant

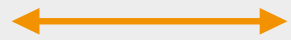

Measurements



Actions

K-FLEX® IN CLAD - FLANGES

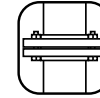

COVERING OF FLANGES INSTALLED ON VERTICAL PIPES

E) Prepare a strip of IN CLAD sheet corresponding to the circumference of the valve's body, plus 5 cm of abundance to allow for the overlapping of the joining edges, with indentations on the upper part.

Apply the sheet around the valve's body and seal the joints with adhesive (**e1**)

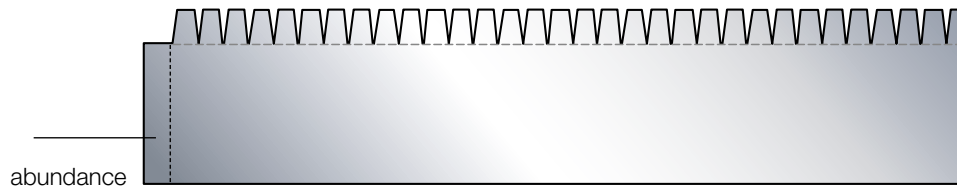

Glue the indentations and fold them onto the flange **e2**)

E) Prepare a second ring with internal indentations and make a cut to facilitate positioning (**f1**).
Install the ring on the flange so that the internal indentations open up around the tube which has not yet been covered (**f2**).
Seal the joints with the correct adhesive (**f3**).

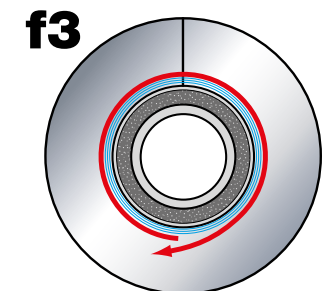
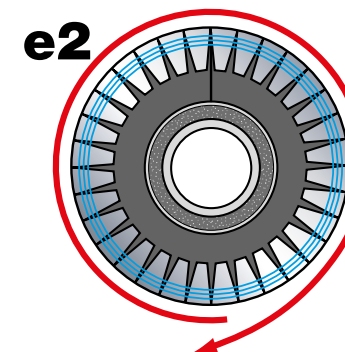
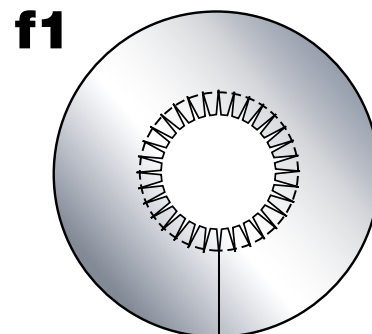
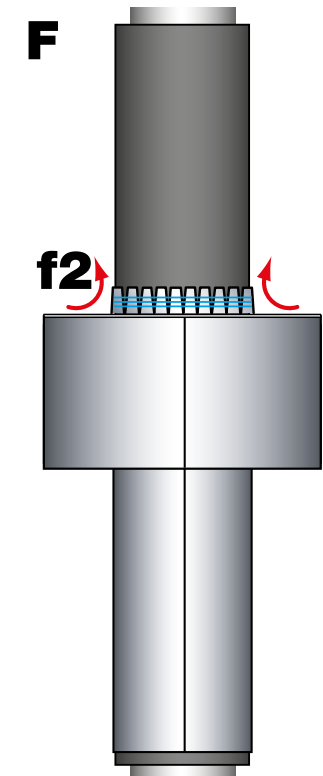
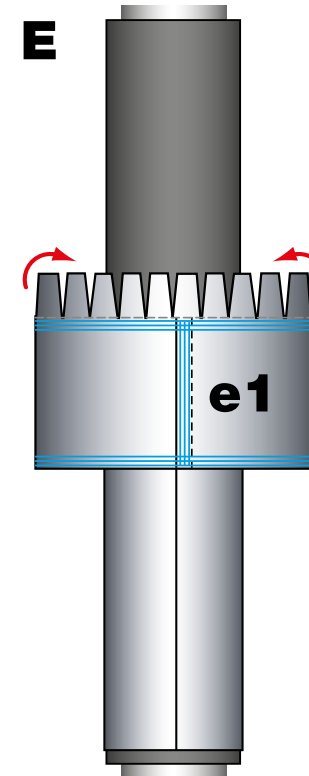

MATERIALS



KEY



K 420 adhesive

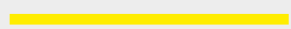

Marine sealant



Measurements



Actions

K-FLEX® IN CLAD - FLANGES

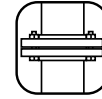

COVERING OF FLANGES INSTALLED ON VERTICAL PIPES

G) Prepare a strip of IN CLAD sheet corresponding to the circumference of the insulated tube, plus an abundance of 5 cm to allow overlapping of the joining edges.



H) Apply the sheet around the tube, flush to the flange disk to secure the indentations still visible in **F**).

Glue the overlapping edges.

I) If necessary, seal all joints with the specific IN CLAD tape.

L) Seal the joining edges and tapes with marine sealant.

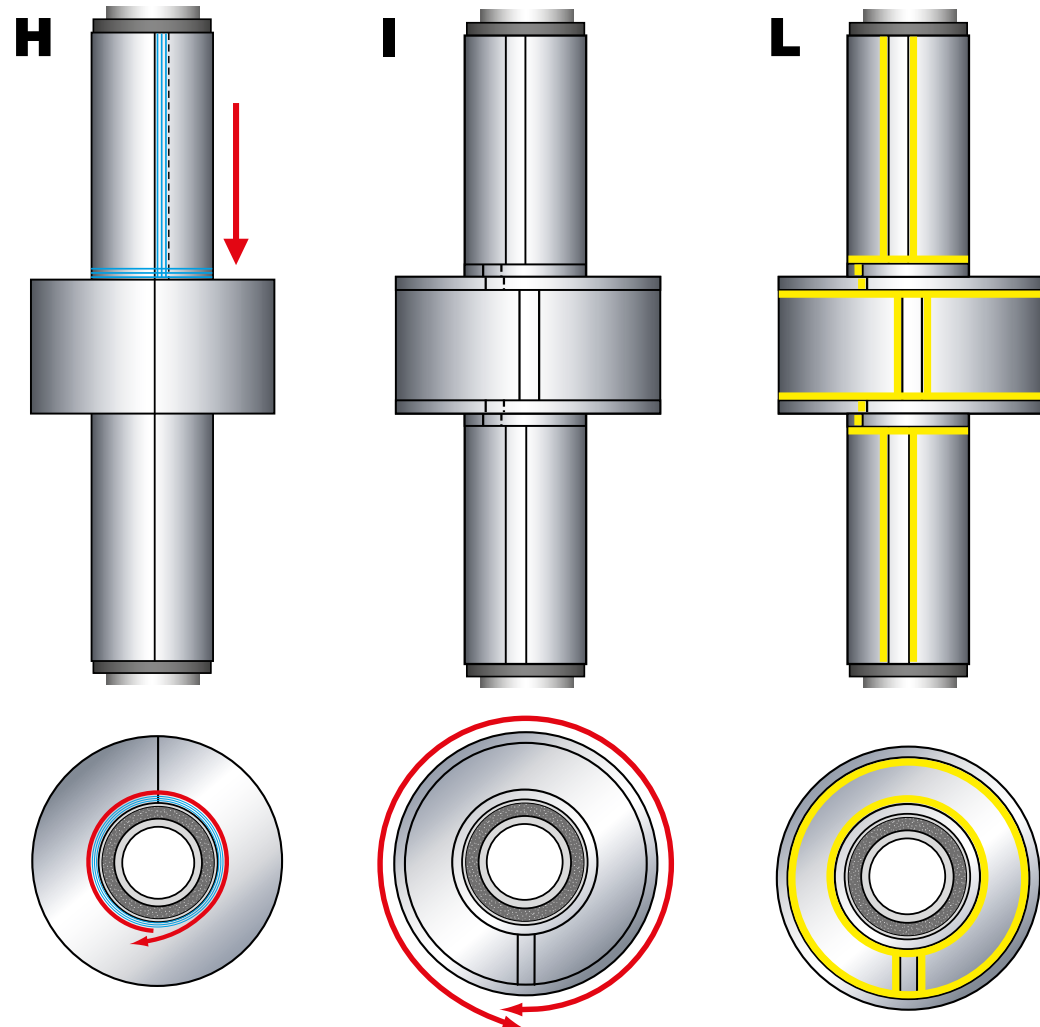

MATERIALS



KEY



K 420 adhesive



Marine sealant



Measurements



Actions

K-FLEX® IN CLAD - FLANGES

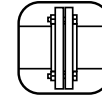

COVERING WITH K-FLEX® PRE-SHAPED FLANGES, PRE-COVERED WITH IN CLAD SHEET

The K-FLEX® pre-shaped flanges are formed by a sectioned body of elastomeric insulation already covered with IN CLAD sheet, in black or grey.

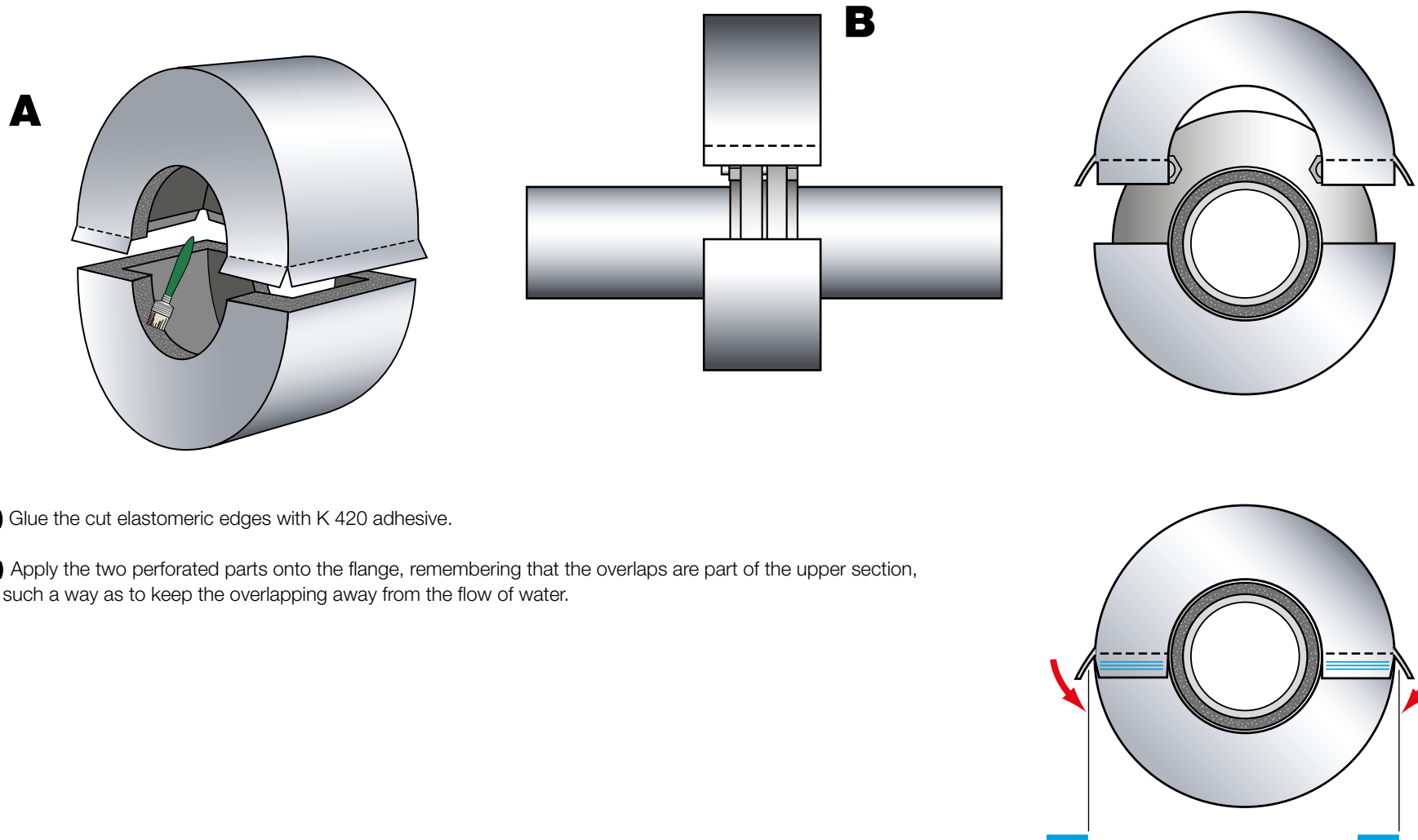

A) Glue the cut elastomeric edges with K 420 adhesive.

B) Apply the two perforated parts onto the flange, remembering that the overlaps are part of the upper section, in such a way as to keep the overlapping away from the flow of water.

MATERIALS

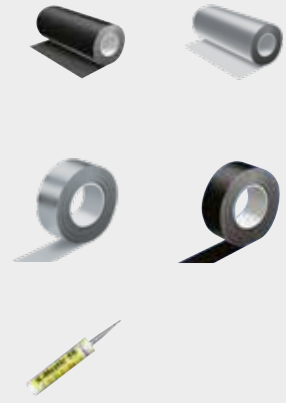

KEY



K 420 adhesive

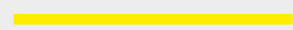

Marine sealant



Measurements



Actions

K-FLEX® IN CLAD - FLANGES

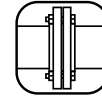

COVERING WITH K-FLEX® PRE-SHAPED FLANGES, PRE-COVERED WITH IN CLAD SHEET

C) Seal all the visible joints, including those of the preshaped parts, with marine sealant.

D) If necessary, seal the joints with the specific IN CLAD tape. Seal the edges of joints and tapes with marine sealant.

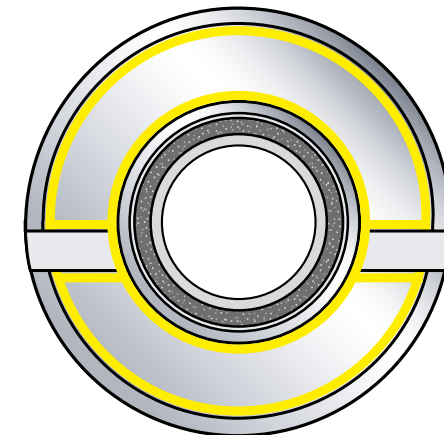
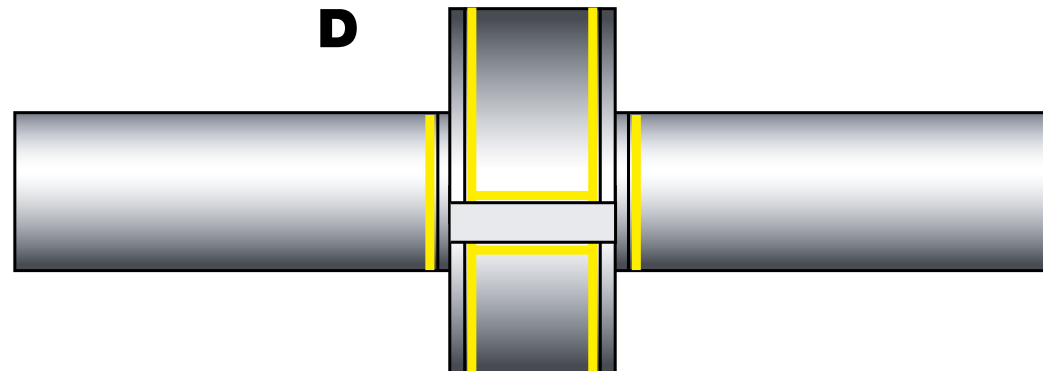
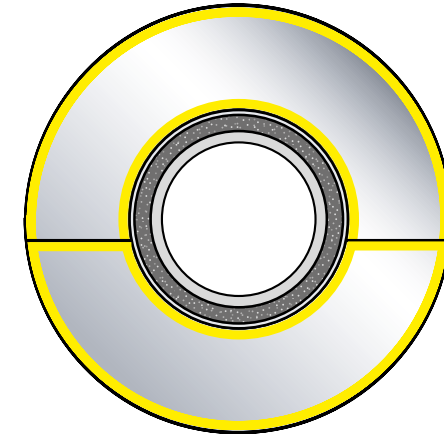
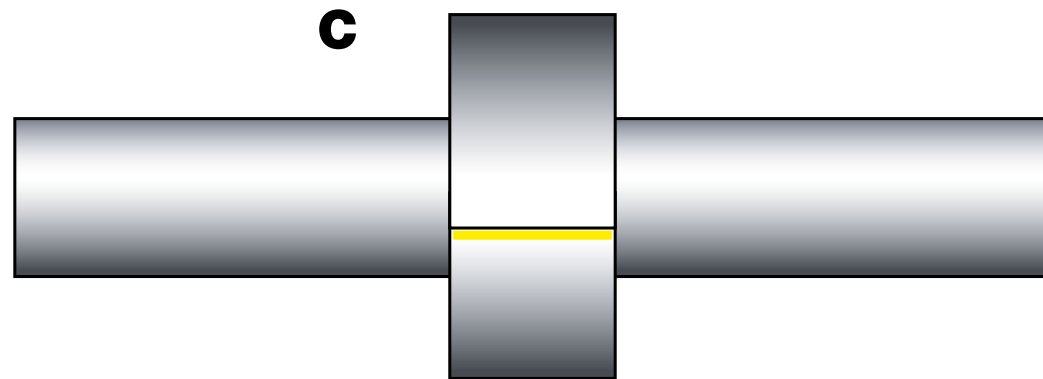

K-FLEX® IN CLAD VALVES

In the application sequence the **IN CLAD IG (Grey)** finishing is represented. The indications are also the same for the use of **IN CLAD IB (Black)** finishing.



For the application procedures of K-FLEX® insulating prepared by the installer with sheet sections, see the relevant sections of the K-FLEX® APPLICATION GUIDE

If you are not in possession of a printed guide you can ask for it at our technical dept. or download the PDF file from our website: www.kflex.com

MATERIALS



KEY



K 420 adhesive

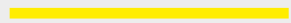

Marine sealant

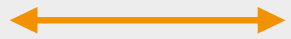

Measurements



Actions

K-FLEX® IN CLAD - VALVES



COVERING OF VERTICAL VALVE

Cut out the two sections of IN CLAD sheet for covering the two parts of the pipe (1-2) leaving an abundance of 5 cm for the overlap.

Install the two sections of sheet on the tubes, folding the indentation on the upper and lower edges of the valve's body.

Fix the overlap (3-4) and the indentation (5) with adhesive.

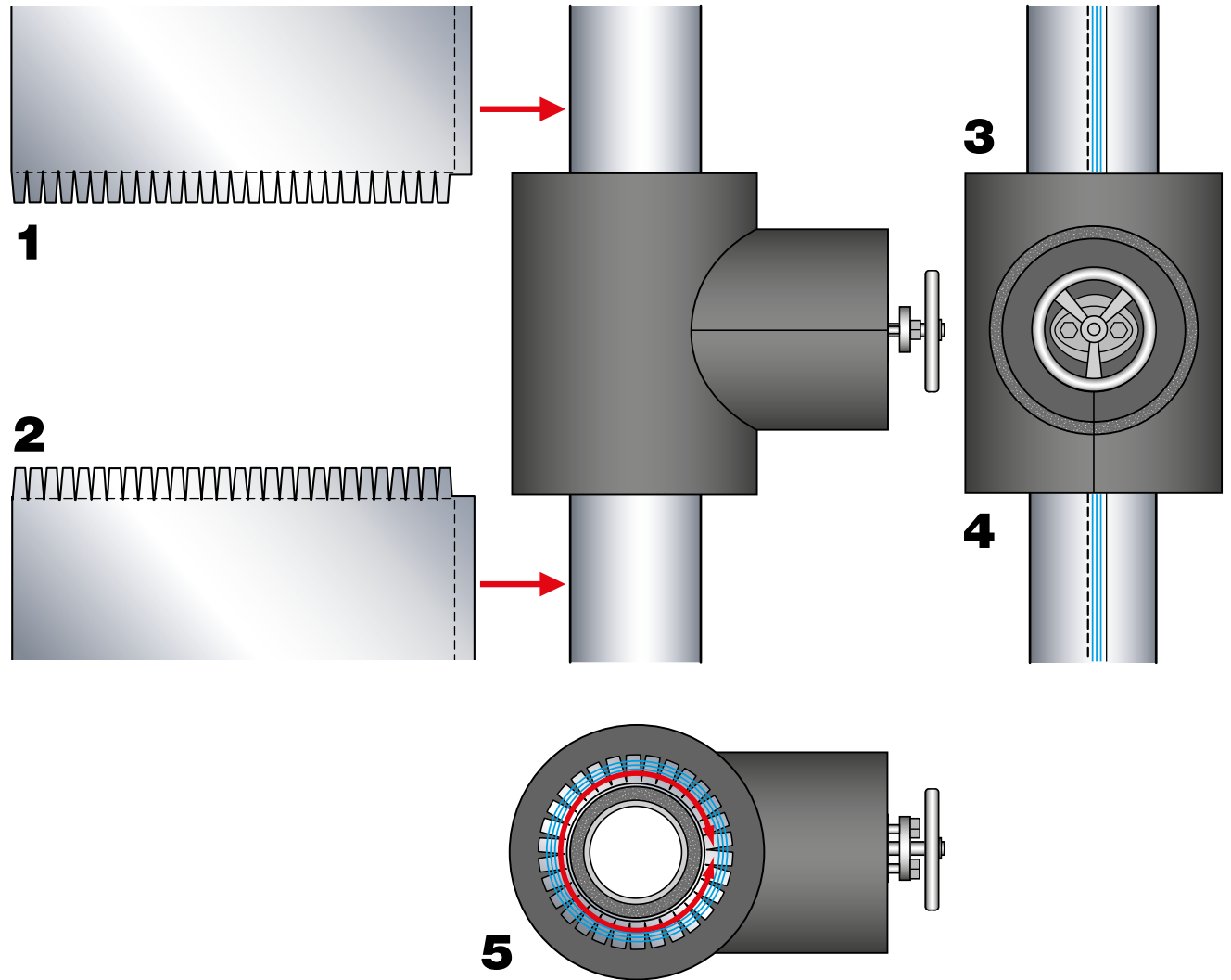

MATERIALS



KEY



K 420 adhesive



Marine sealant



Measurements



Actions

K-FLEX® IN CLAD - VALVES



COVERING OF VERTICAL VALVE

Cut out a ring, the diameter of the cylindrical body of the valve, with the external indentation and the central hole corresponding to the diameter of the tubes already covered (1).

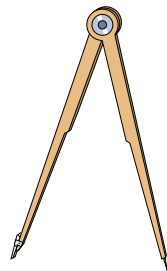

Make an opening cut (1a) on the indented ring and place it on the lower edge of the valve.

Fold the indentations on the cylindrical body of the valve and fix it with adhesive (2-3-4).

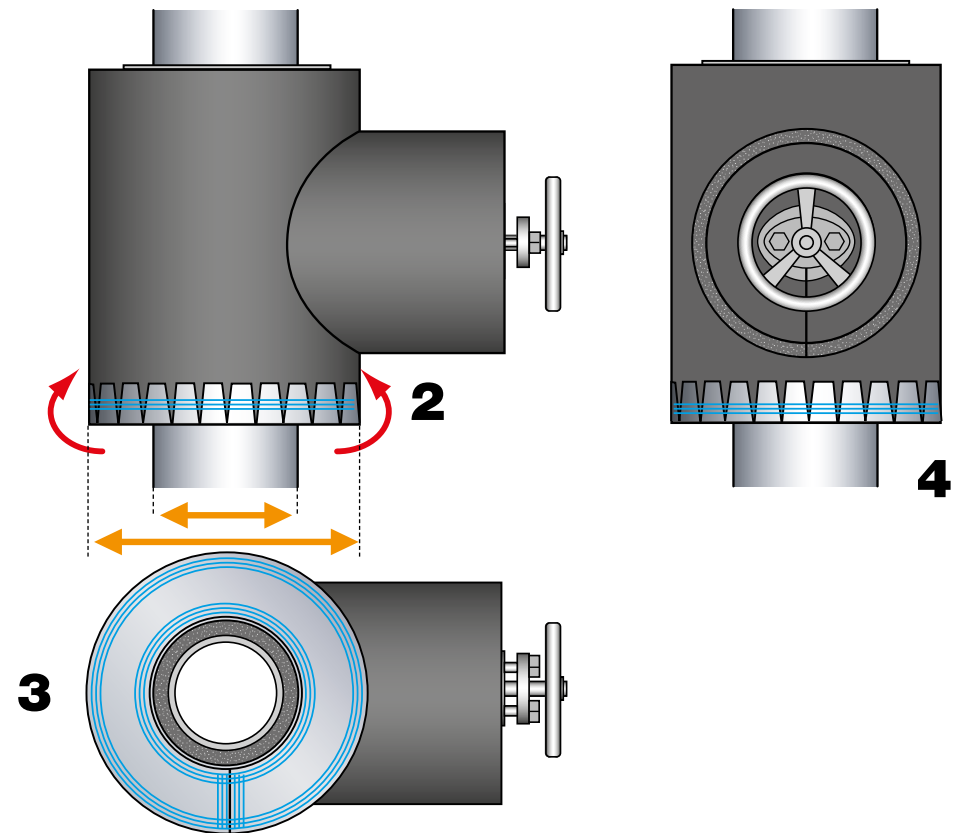
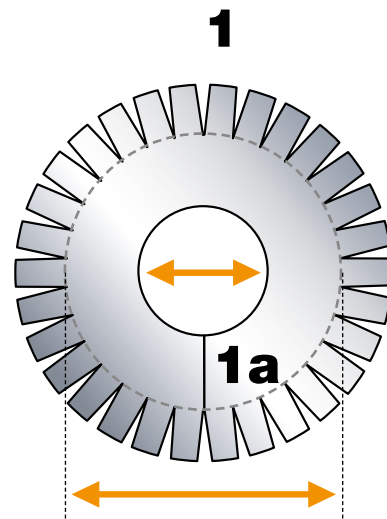

MATERIALS



KEY



K 420 adhesive



Marine sealant

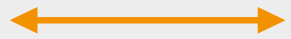

Measurements



Actions

K-FLEX® IN CLAD - VALVES



COVERING OF VERTICAL VALVE

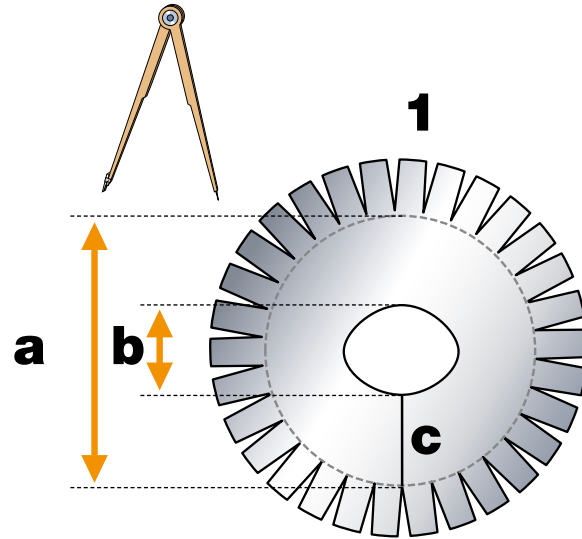

Cut out an indented disc **(1)** for the finishing of the front part of the box, with a central hole corresponding to the support of the manual control device **(b)**.
On the shaped ring also make an opening cut **(c)**.

Place the ring on the front of the stuffing box and fix it with adhesive **(5)**.
Fold the indentations on the cylindrical body of the box and fix them with adhesive **(2-3-4)**.

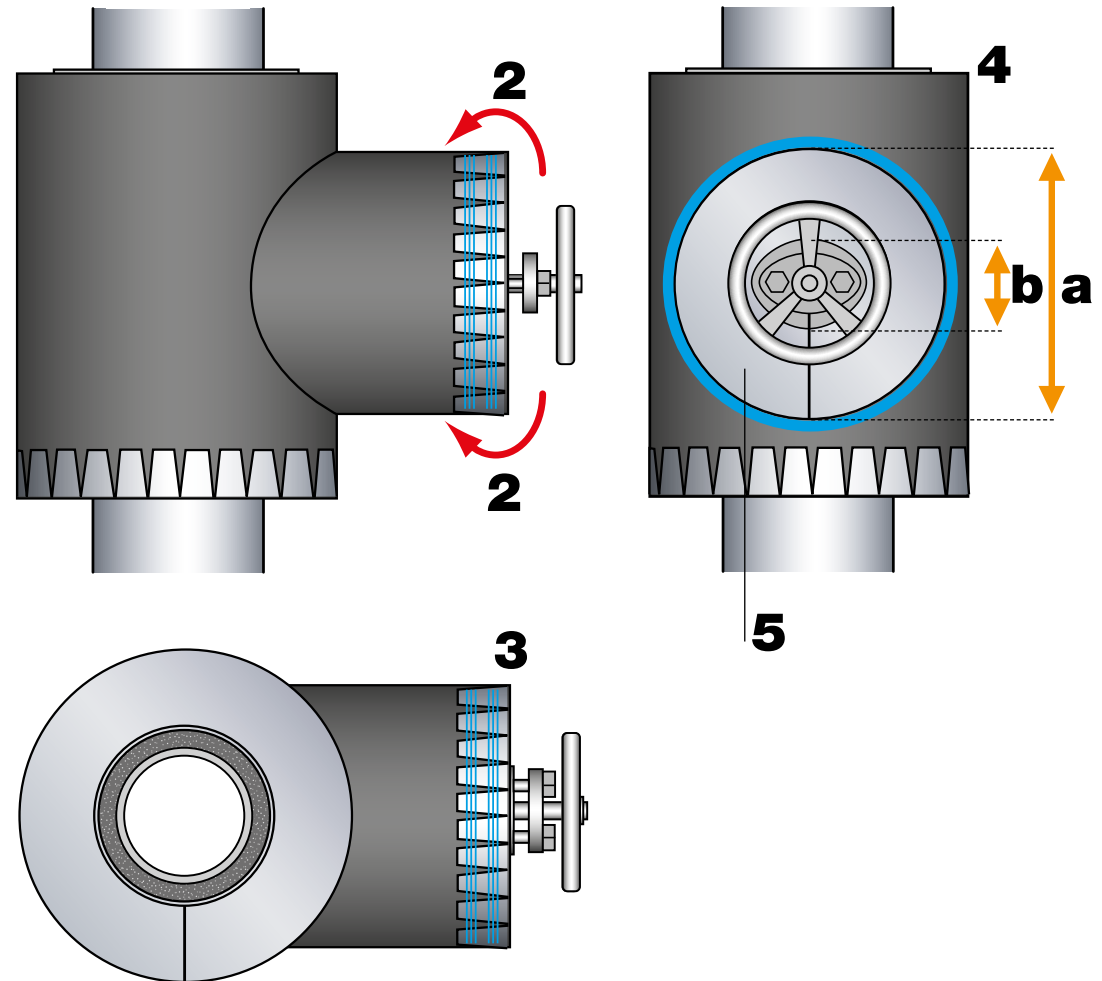

MATERIALS



KEY



K 420 adhesive



Marine sealant

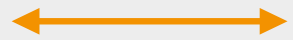

Measurements



Actions

K-FLEX® IN CLAD - VALVES



COVERING OF VERTICAL VALVE

With the appropriate template cut out the finishing of the box body, leaving an excess for the overlapping of the joints. **(1-2)**.
On the curved part of the shape make an indentation of at least 5 cm.

Apply the shape on the box opening the indentation onto the body of the valve.
Fix the finishing with adhesive **(3-4-5)**.

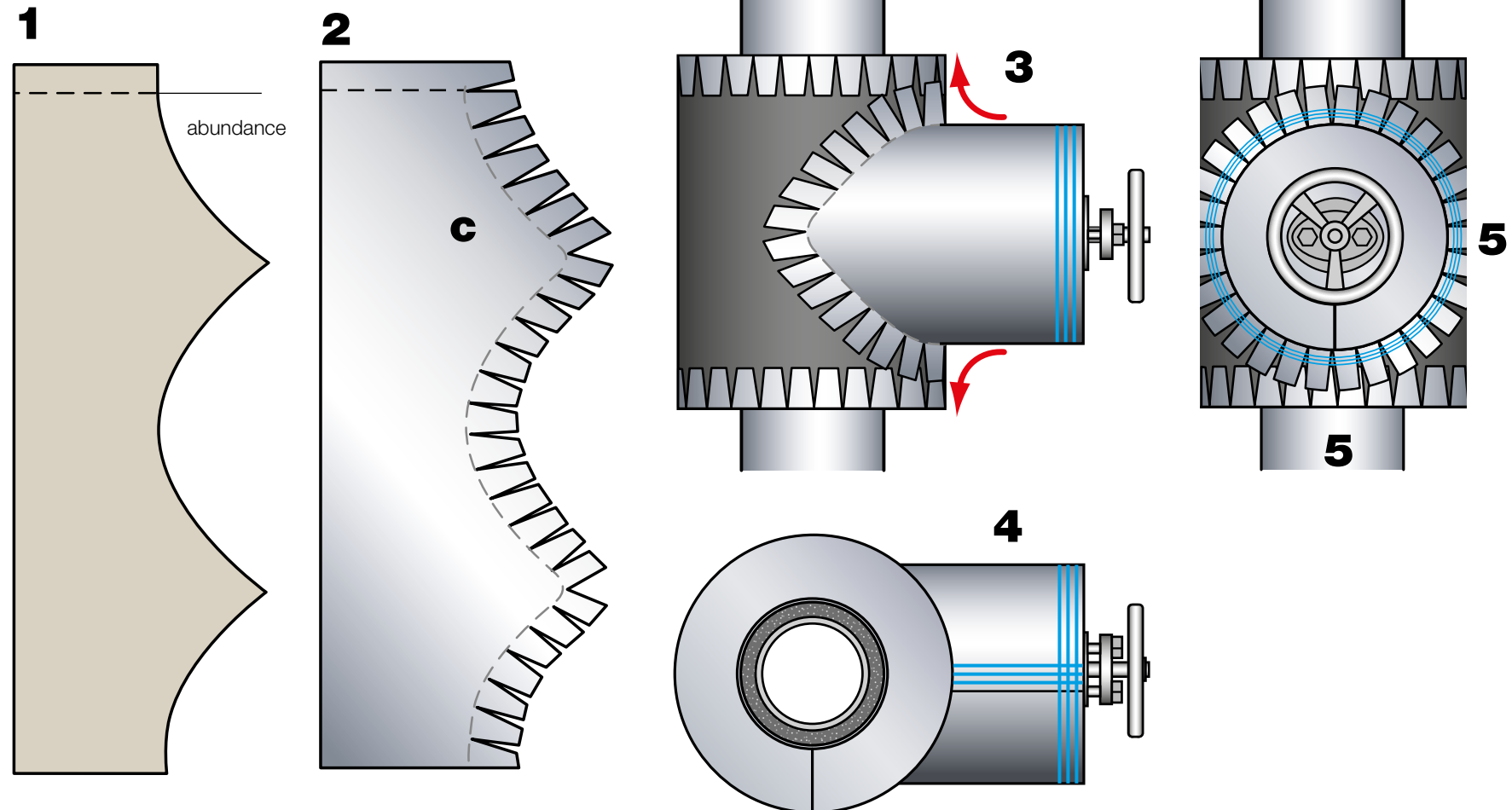

MATERIALS



KEY



K 420 adhesive



Marine sealant

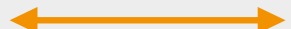

Measurements



Actions

K-FLEX® IN CLAD - VALVES



COVERING OF VERTICAL VALVE

Cut out the covering of the valve's body (1), taking the measurements of the indicated diameters (**a-b-c**), and leave an abundance for the overlap of the joints . On the corresponding side on the upper part, add the indentation. Make an opening cut in the shape (**d**) to allow for installation.

Place the shape around the valve's body, folding the indentation on the upper part (2)

Fix the finishing parts with adhesive (3-4-5).

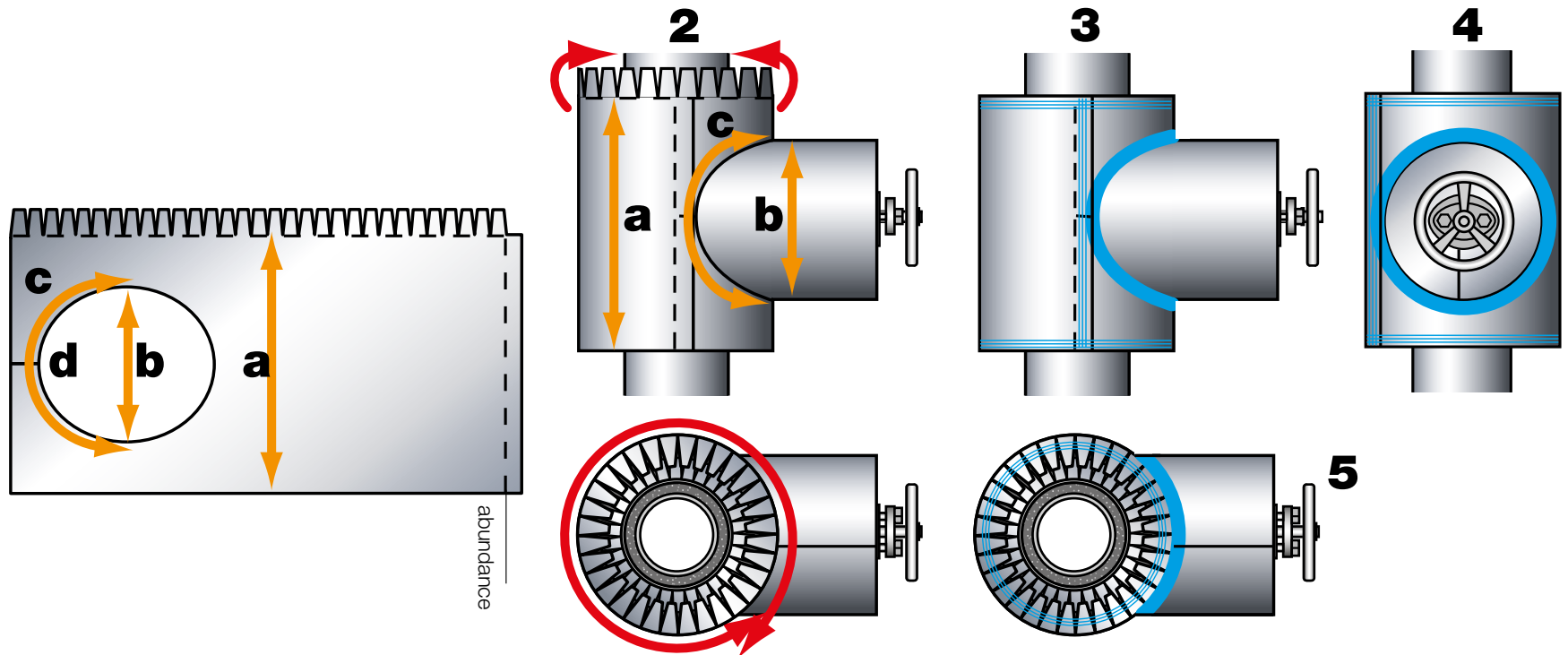

MATERIALS



KEY



K 420 adhesive



Marine sealant



Measurements



Actions

K-FLEX® IN CLAD - VALVES



COVERING OF VERTICAL VALVE

Measure the indicated diameters (**a-b**) and trace a ring on a section of IN CLAD sheet for the finishing of the upper part of the valve's body. Cut out the ring and make an opening cut (**c**).

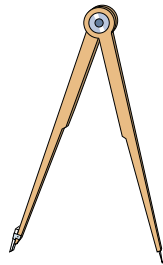

Apply the ring on the upper part of the valve's body and fix it with adhesive.

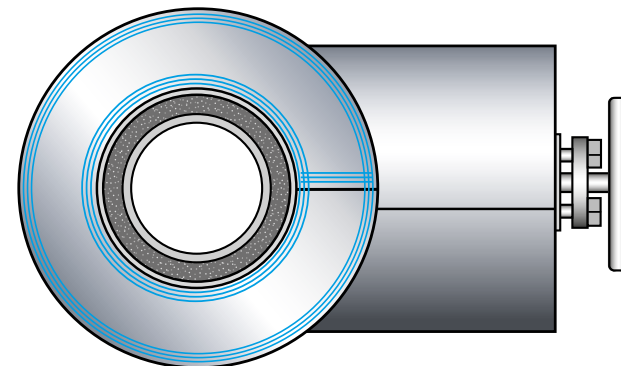
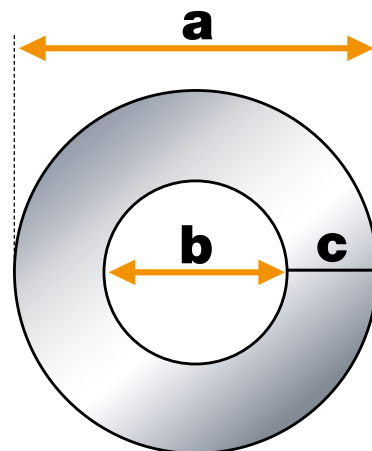
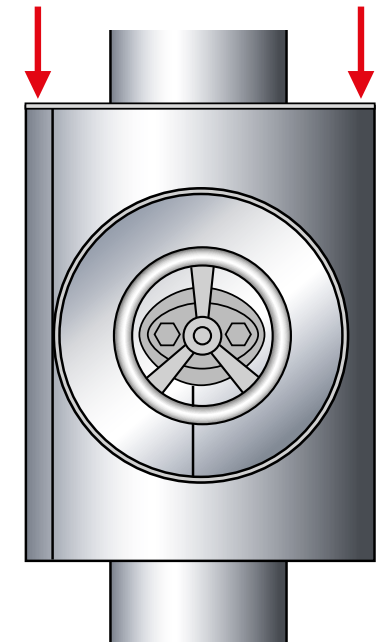
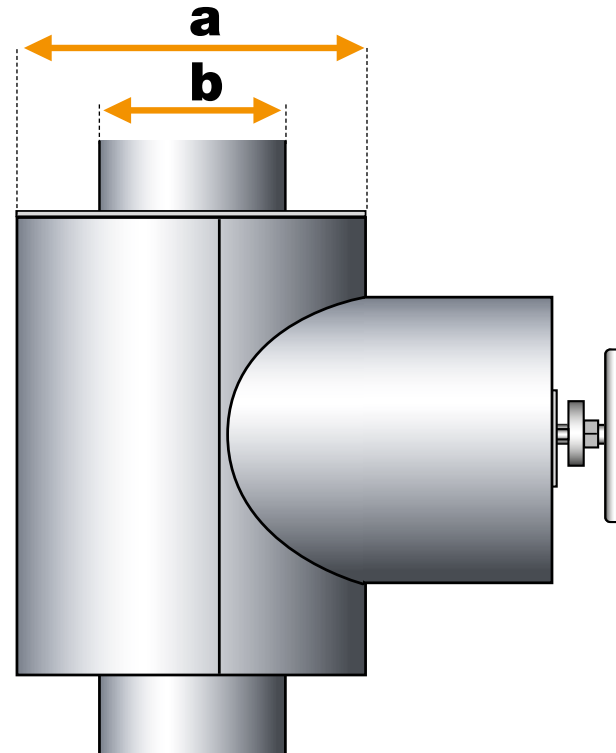

If necessary and possible, subsequently fix the joints with the specific IN CLAD tape, applied with adhesive.

MATERIALS

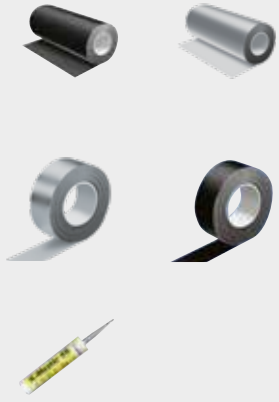

KEY

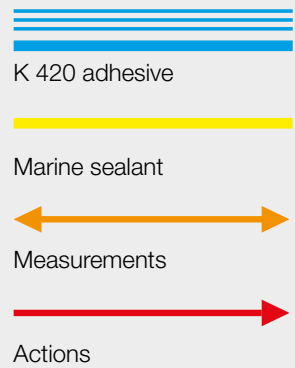

K-FLEX® IN CLAD - VALVES



COVERING OF VERTICAL VALVE

If necessary, seal the joints with the specific IN CLAD tape secured with glue. Seal the joints with marine sealant.

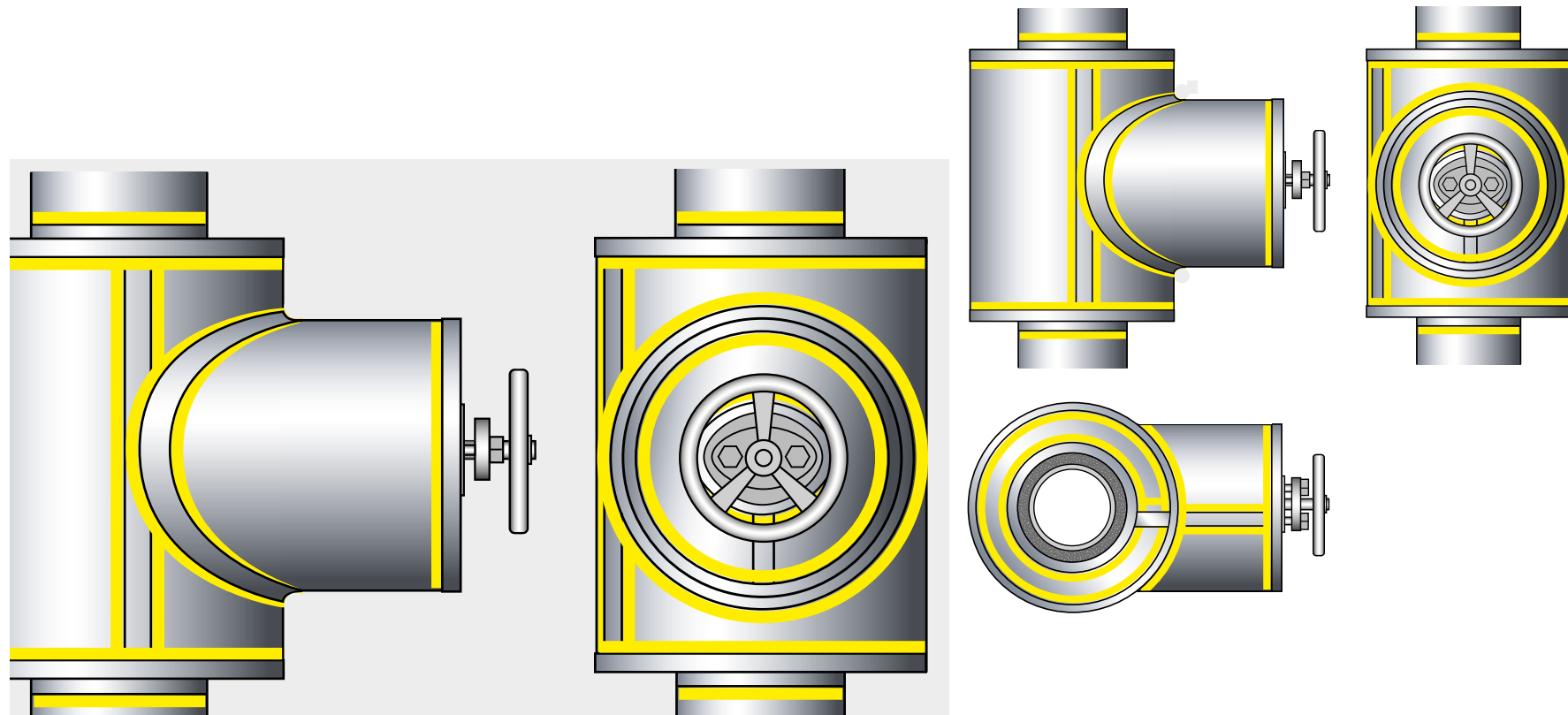

MATERIALS



KEY



K 420 adhesive

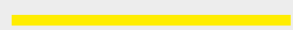

Marine sealant

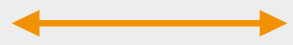

Measurements



Actions

K-FLEX® IN CLAD - VALVES



VALVE COVERING WITH VALVE BOX FACING DOWNWARDS

1) Cut out two sections of IN CLAD sheet (I - II) of a length corresponding to the circumference of the straight insulated tubes (a). Make indentations along the side that will be placed on the valve, with an abundance of 5 cm for the overlapping of the longitudinal joints.

2) Apply each sections on its respective tube with the indentations folded onto the external flange disks of the valve's body (b). The longitudinal joints should be turned away from the flow of water (c), and the indentations should be sealed with adhesive.

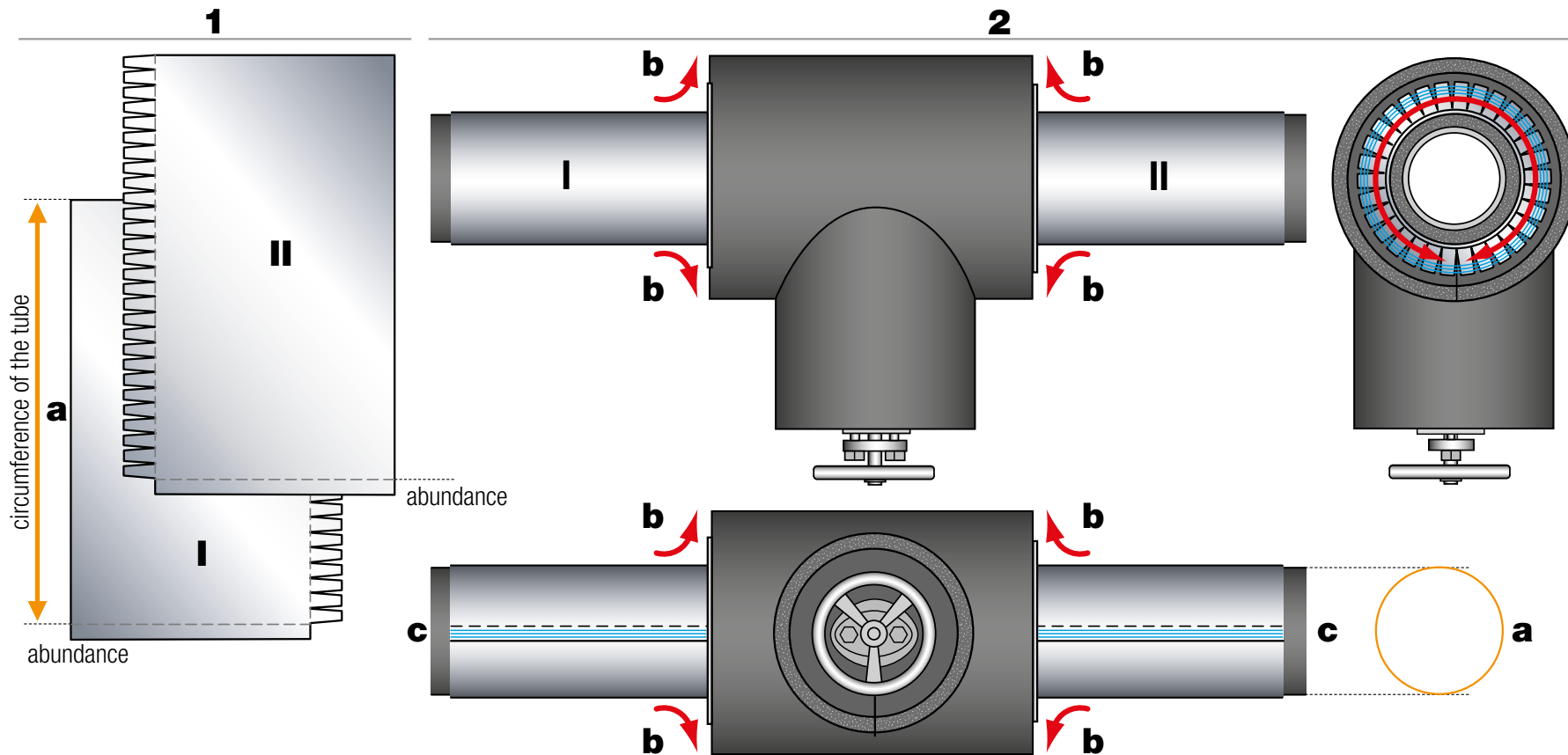

MATERIALS



KEY



K 420 adhesive

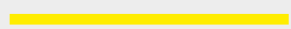

Marine sealant



Measurements



Actions

K-FLEX® IN CLAD - VALVES



VALVE COVERING WITH VALVE BOX FACING DOWNWARDS

- 1)** Measure the diameters indicated (**a-b**) and cut out the two flanges covering rings of the valve's body, complete with external indentations and an opening cut (**c**).
- 2)** Place the two rings, one on each side (**d**).
- 3)** Fold the indentations onto the valve's body (**e**). Fix down the two rings and the indentations with the correct adhesive.

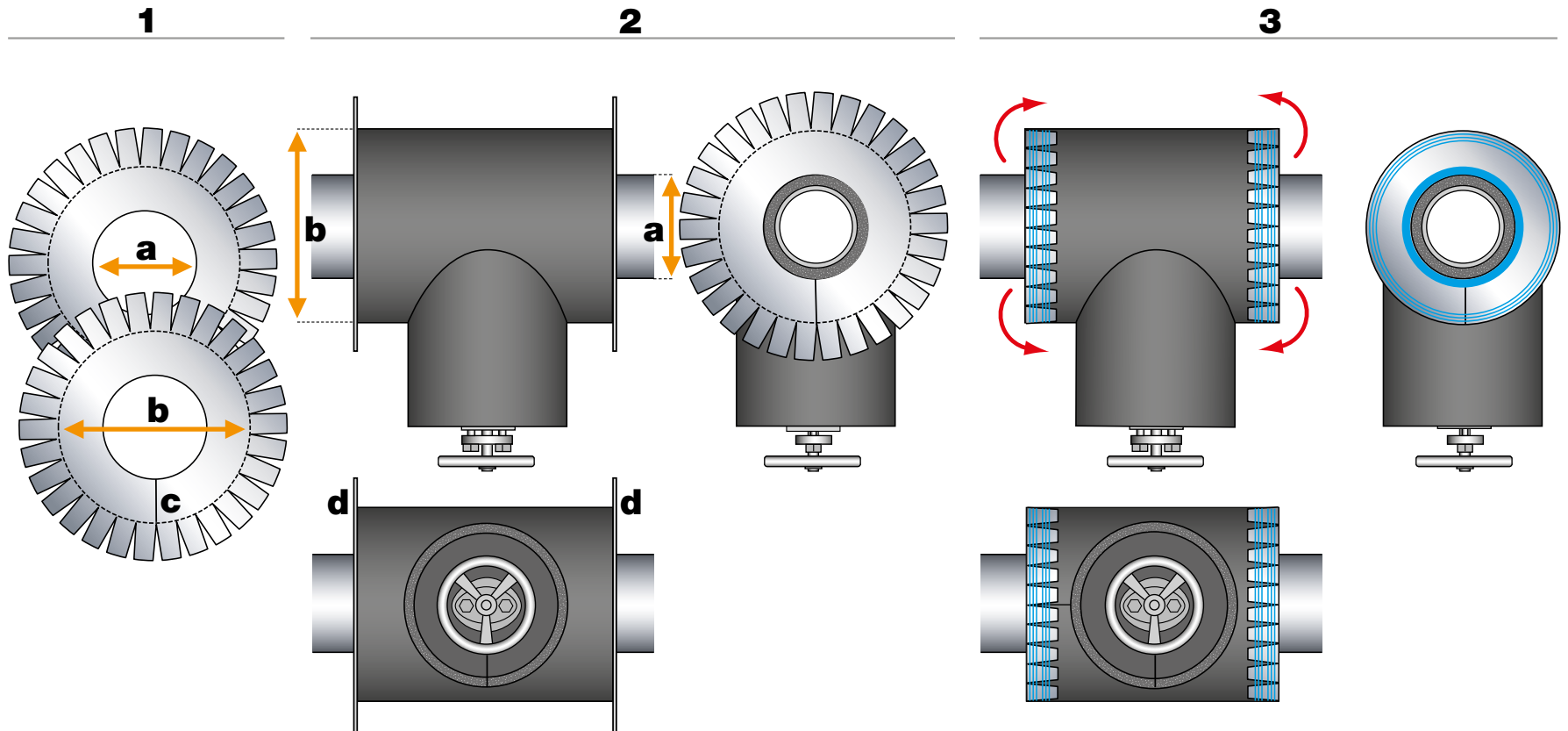

MATERIALS



KEY

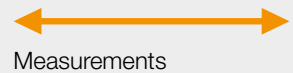

K-FLEX® IN CLAD - VALVES



VALVE COVERING WITH VALVE BOX FACING DOWNWARDS

- 1)** Take the measurements indicated and cut out the shape for the front disk of the valve box. Make an opening cut (**d**).
- 2)** Place the shape on the front disk (**2**)
- 3)** Fold the indentations onto the body of the valve box. Seal the indentations and the front disk with adhesive.

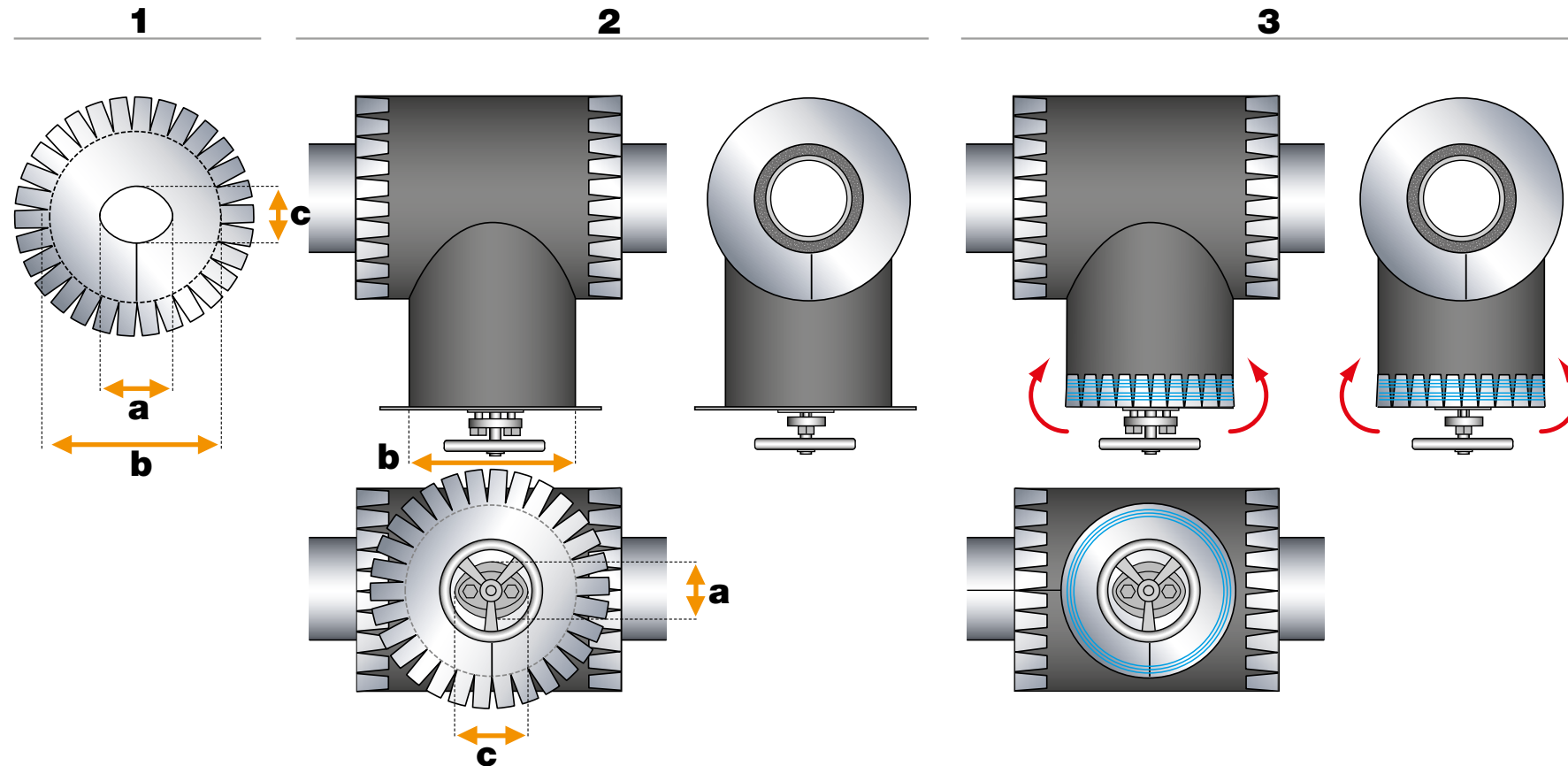

MATERIALS



KEY



K 420 adhesive



Marine sealant

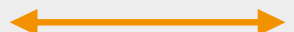

Measurements



Actions

K-FLEX® IN CLAD - VALVES



VALVE COVERING WITH VALVE BOX FACING DOWNWARDS

- 1)** Using the appropriate template (a) cut out a section of IN CLAD sheet (b) for covering the body of the valve box. Make indentations along the curved part and leave an excess for the overlapping of the longitudinal joints.
- 2)** Place the shape on the valve box folding the indentations onto the valve's body. Fix the longitudinal joints and the indentations with the correct adhesive.

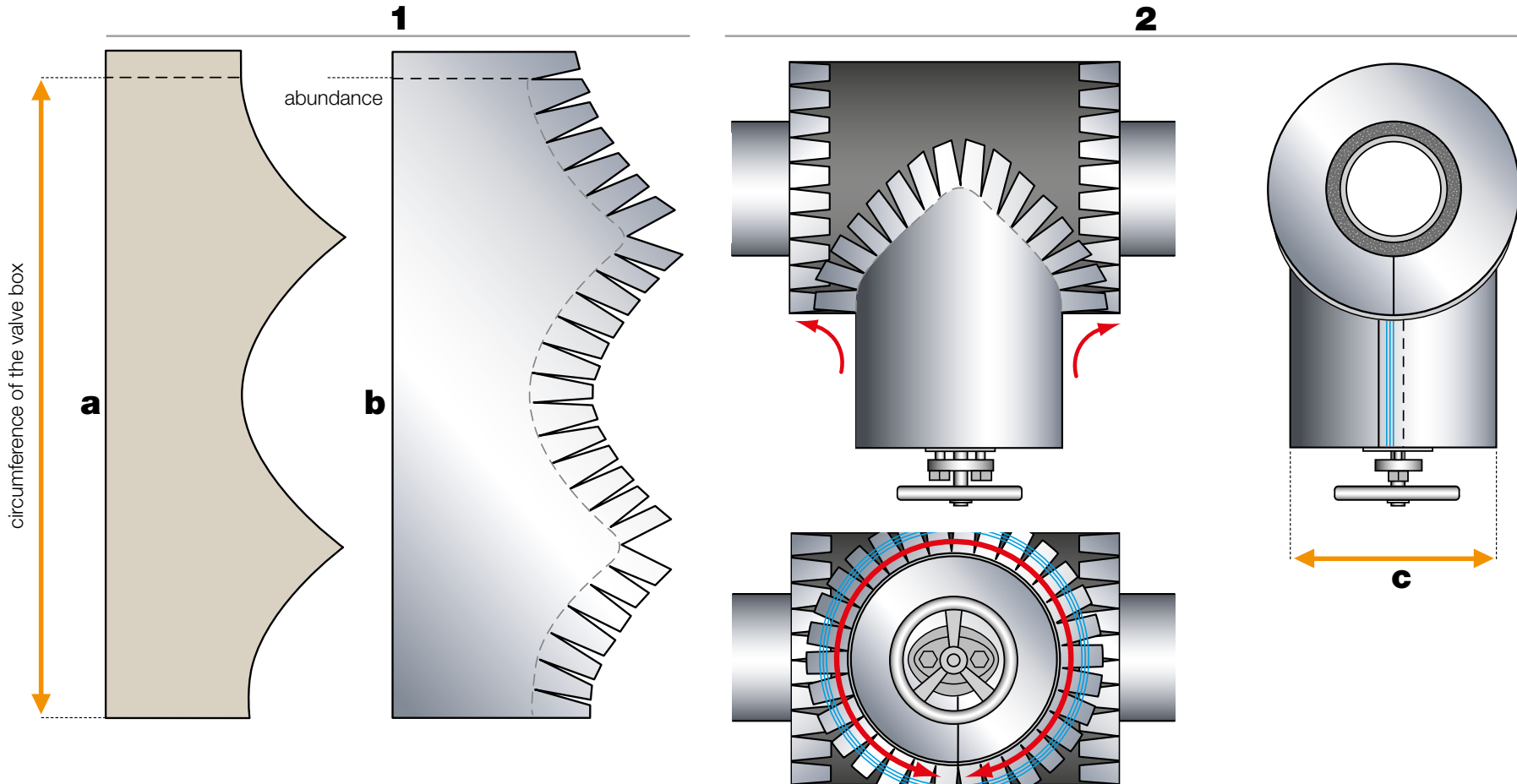

MATERIALS



KEY

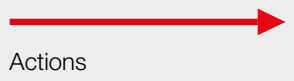
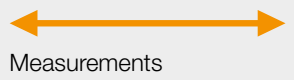
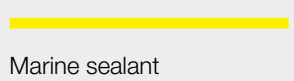

K-FLEX® IN CLAD - VALVES



VALVE COVERING WITH VALVE BOX FACING DOWNWARDS

- 1) Cut out the covering of the valve's body using the indicated measurements (**a-b-c-d**). Leave an excess for the overlapping of the joining edges. Make an opening cut (**e**).
- 2) Place the shape around the valve's body, keeping the overlapped edges of the longitudinal joints away from the flow of water (**f**).

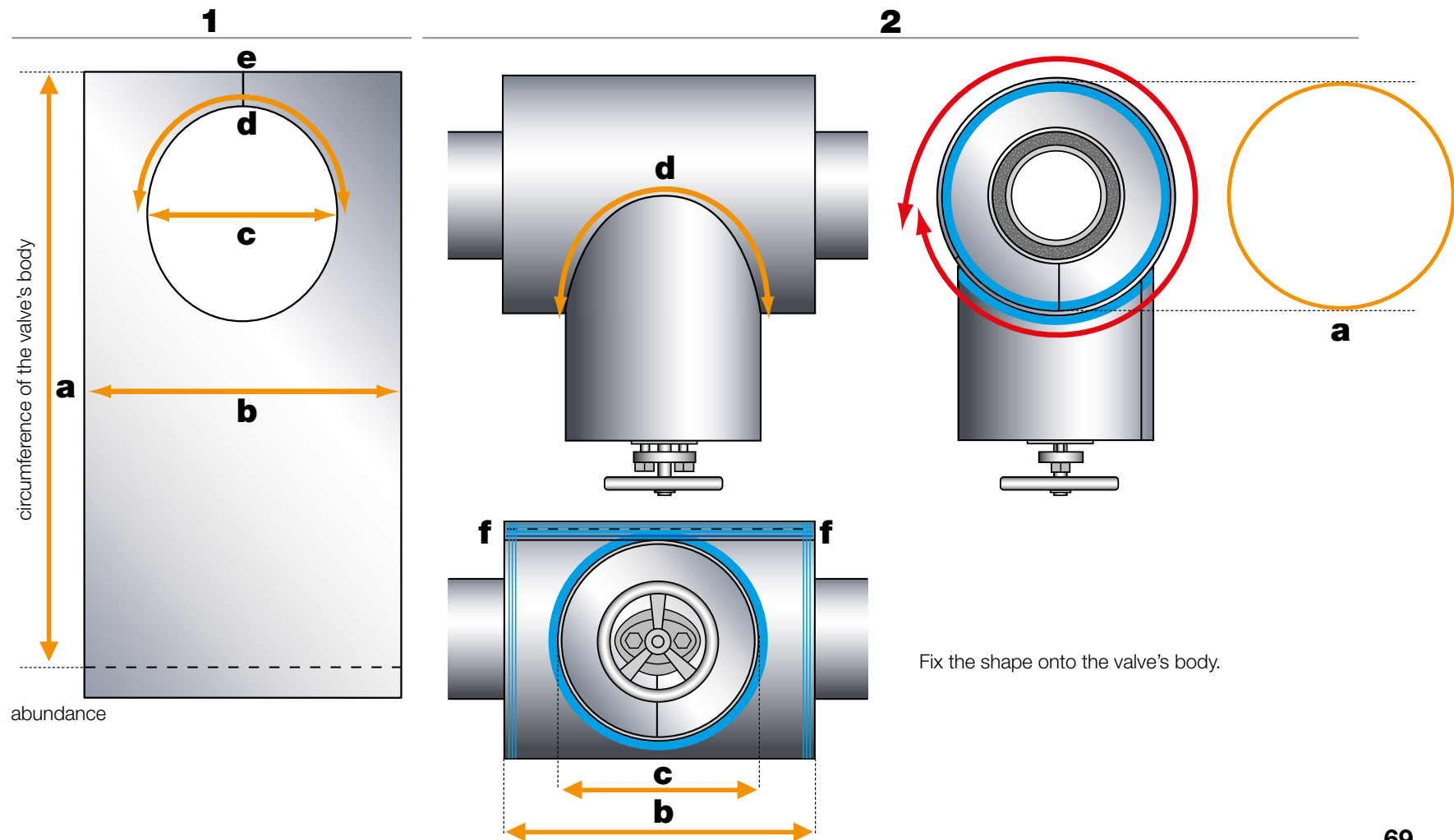

MATERIALS

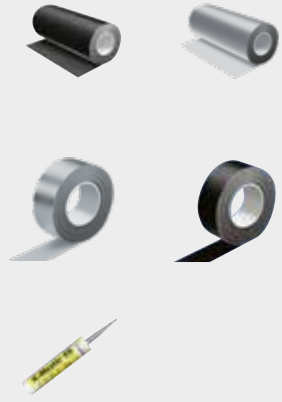

KEY



K 420 adhesive

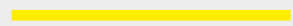

Marine sealant



Measurements



Actions

K-FLEX® IN CLAD - VALVES



VALVE COVERING WITH VALVE BOX FACING DOWNWARDS

- 1) Seal the joints with marine sealant.
- 2) If necessary, seal the joints with the specific IN CLAD tape secured with glue.

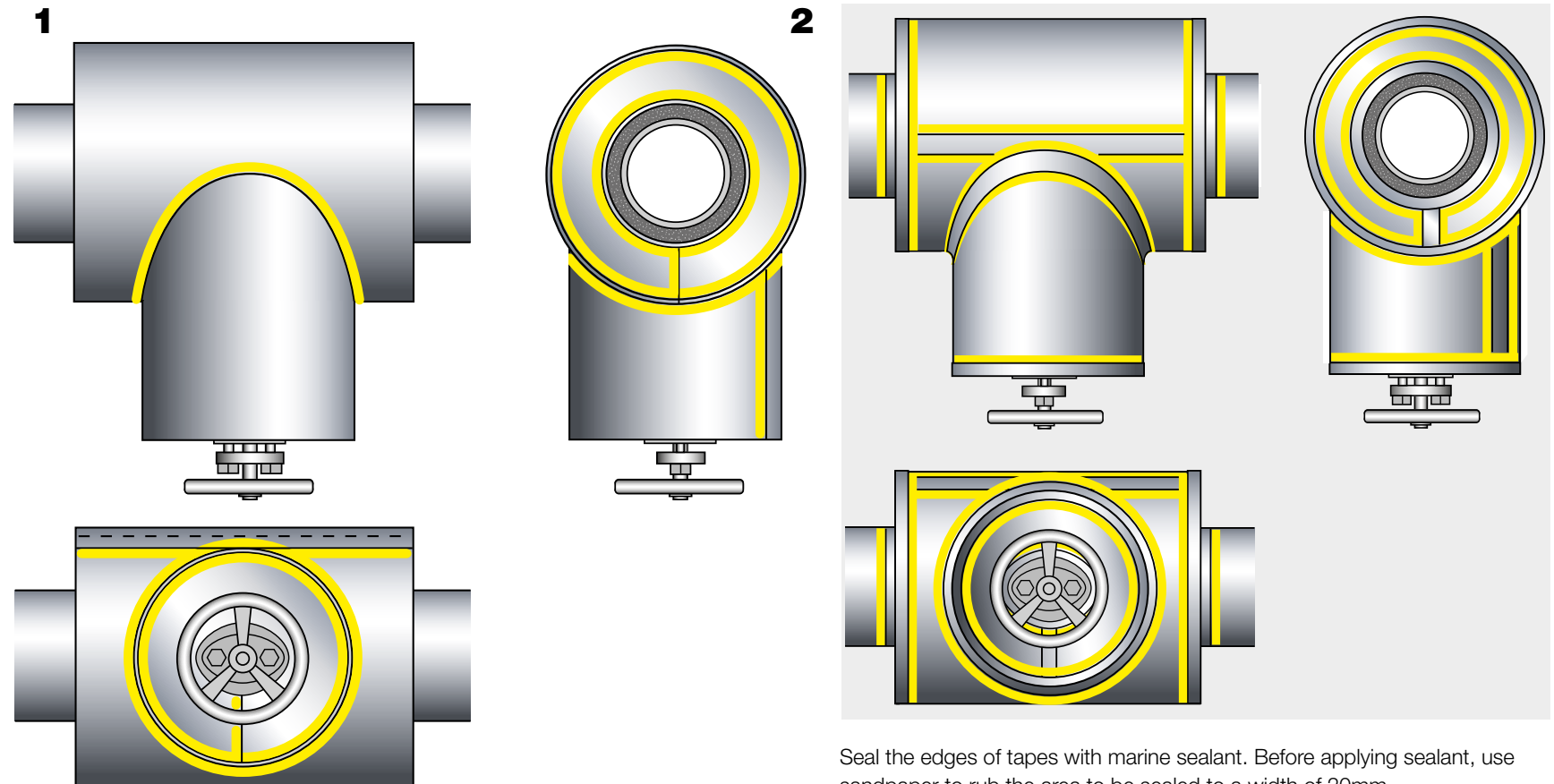

Seal the edges of tapes with marine sealant. Before applying sealant, use sandpaper to rub the area to be sealed to a width of 20mm.

MATERIALS



KEY

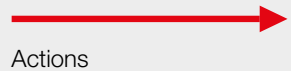
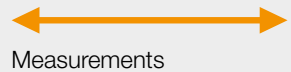
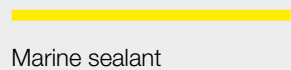

K-FLEX® IN CLAD - VALVES



COVERING OF VALVE WITH VALVE BOX FACING UPWARDS

- 1) Cut out two sections of IN CLAD sheet following the dimensions indicated. Make indentations along the side which comes into contact with the valve and leave an abundance for overlapping the longitudinal joints.
- 2) Apply the shapes on the respective tubes with the indentations folded onto the external flange disks of the valve's body (d). The longitudinal joints, turned against the flow of water, (e) and the indentations should be sealed with the correct adhesive.

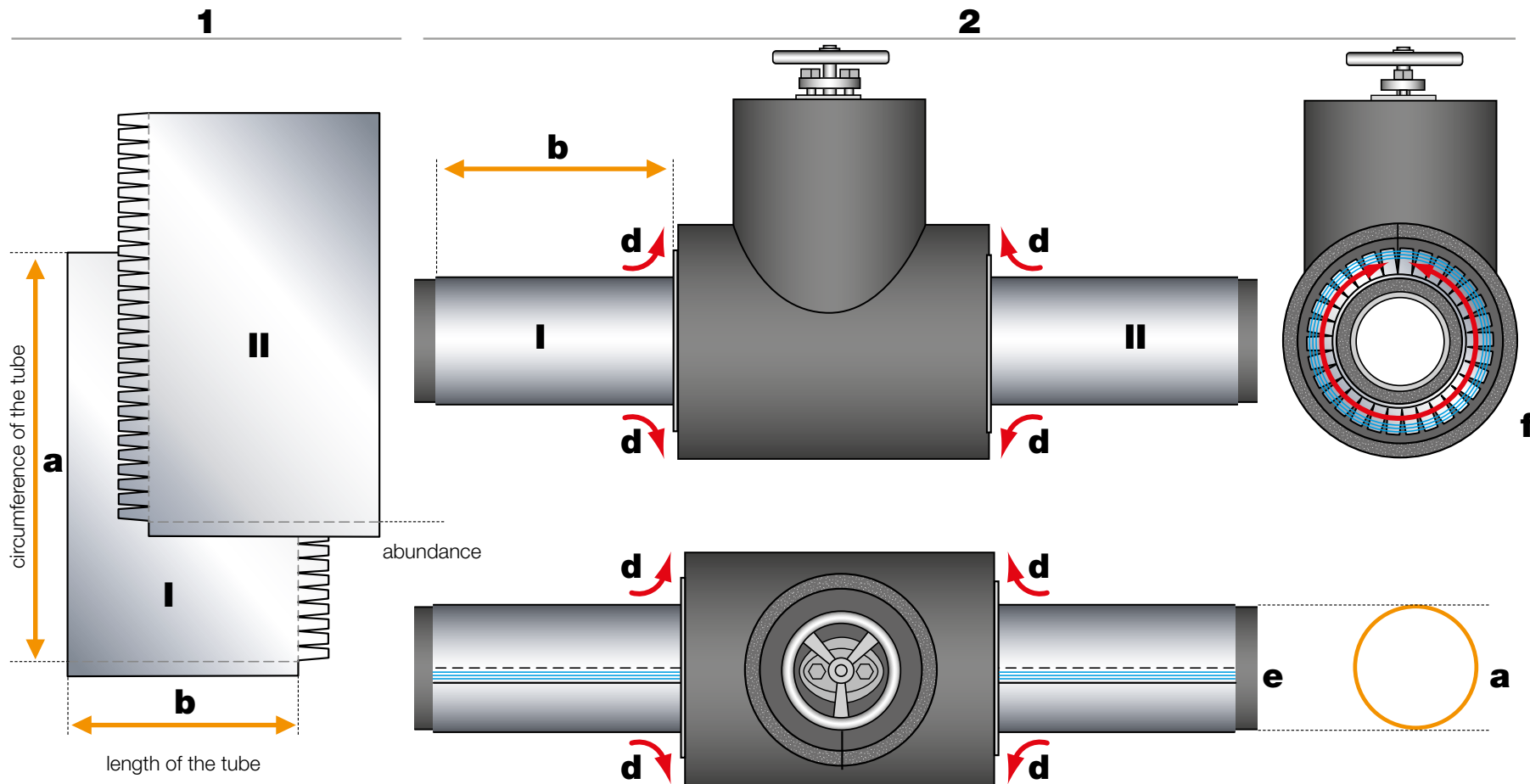

MATERIALS



KEY



K 420 adhesive



Marine sealant



Measurements



Actions

K-FLEX® IN CLAD - VALVES



COVERING OF VALVE WITH VALVE BOX FACING UPWARDS

- 1)** Measure the indicated diameters (**a-b**) and cut out two rings for covering the valve body flanges, complete with external indentations and an opening cut to facilitate positioning (**c**).
- 2)** Fit the rings, one on each side, in contact with the valve body flanges.
- 3)** Fold the indentations onto the body of the valve (**d**). Fix down the indentations and all joining edges with the correct adhesive.

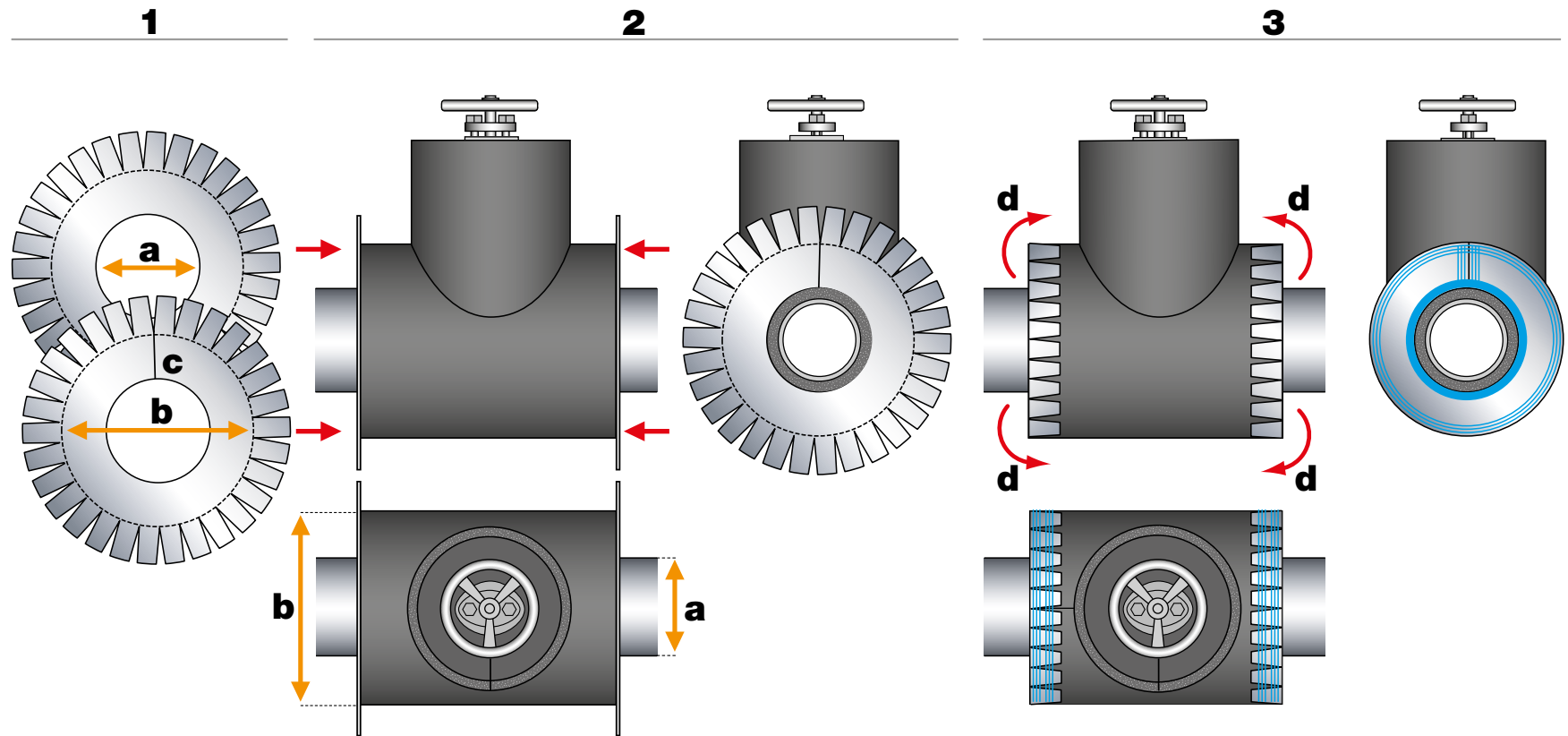

MATERIALS



KEY



K 420 adhesive

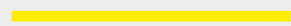

Marine sealant

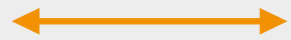

Measurements



Actions

K-FLEX® IN CLAD - VALVES



COVERING OF VALVE WITH VALVE BOX FACING UPWARDS

1) Take the measurements indicated and cut out, from a section of IN CLAD sheet, the covering for the valve's body. Create indentations on the inside of the hole and leave an abundance to allow for overlapping of the longitudinal joints. Make an opening cut to help position the covering around the box (**c**).

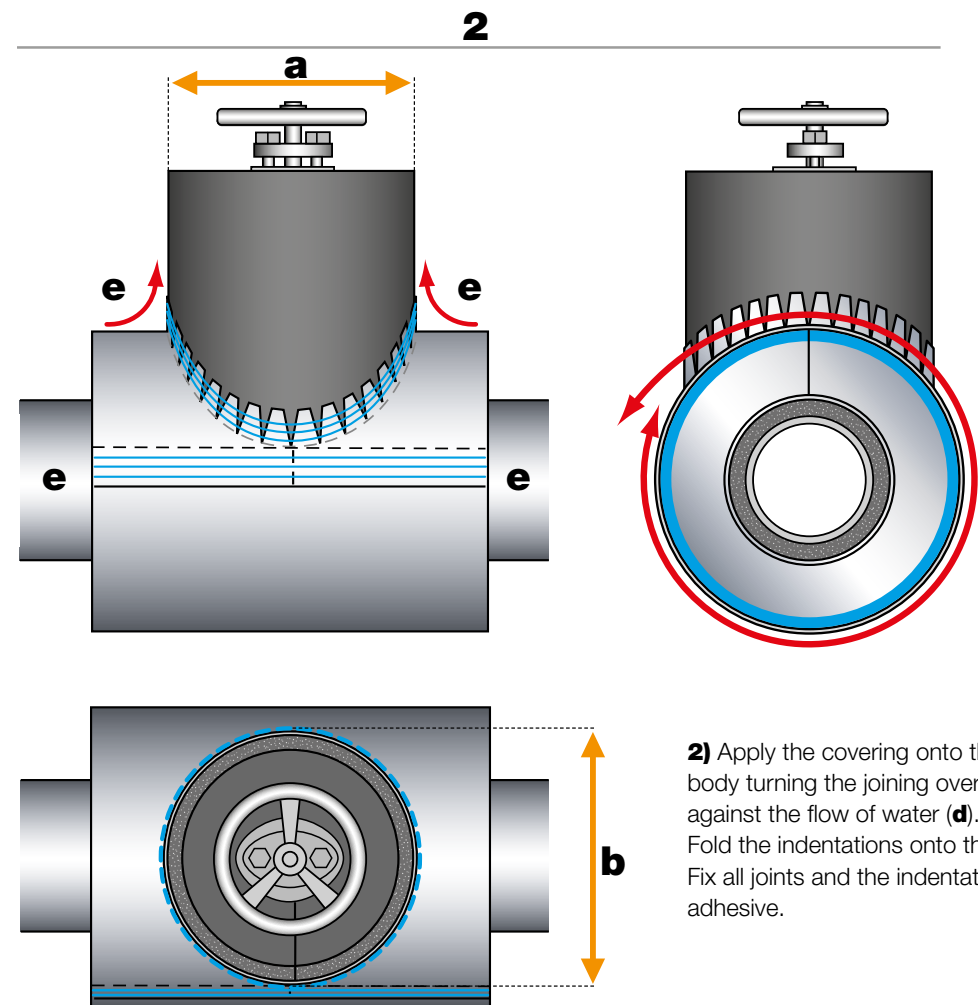
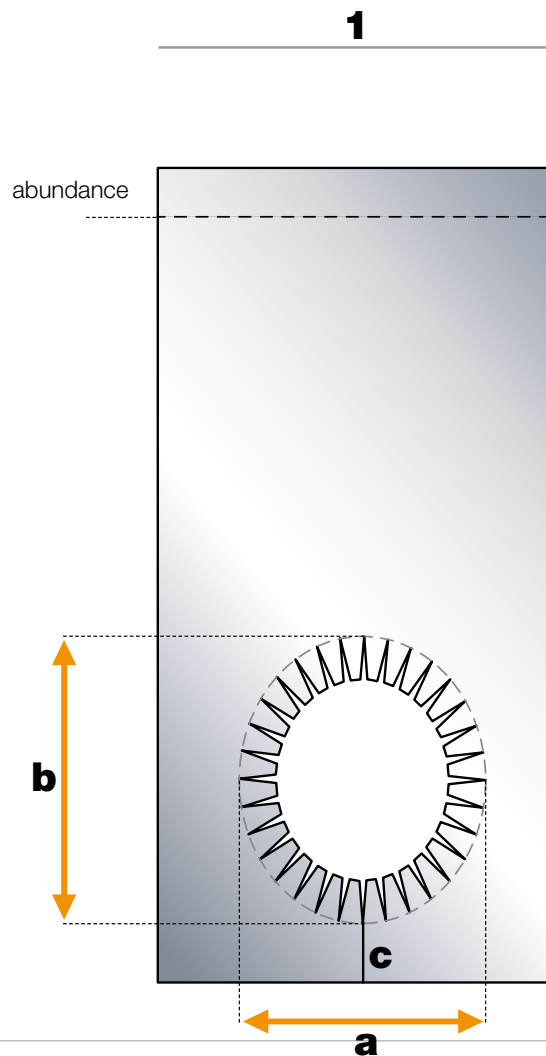

2) Apply the covering onto the valve's body turning the joining overlap against the flow of water (**d**). Fold the indentations onto the box (**e**). Fix all joints and the indentations with adhesive.

MATERIALS



KEY



K 420 adhesive



Marine sealant

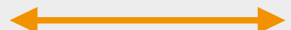

Measurements



Actions

K-FLEX® IN CLAD - VALVES



COVERING OF VALVE WITH VALVE BOX FACING UPWARDS

- 1) Take the indicated measurements (**a-b**) and, using the correct shape, cut out the covering of the valve box from a section of IN CLAD sheet. Leave an abundance for overlapping the joints and make indentations for attaching it to the disk of the box.
- 2) Apply the covering around the cylindrical body. Overlap the edges (**c**) and fold the indentations onto the disk of the valve box (**d**).

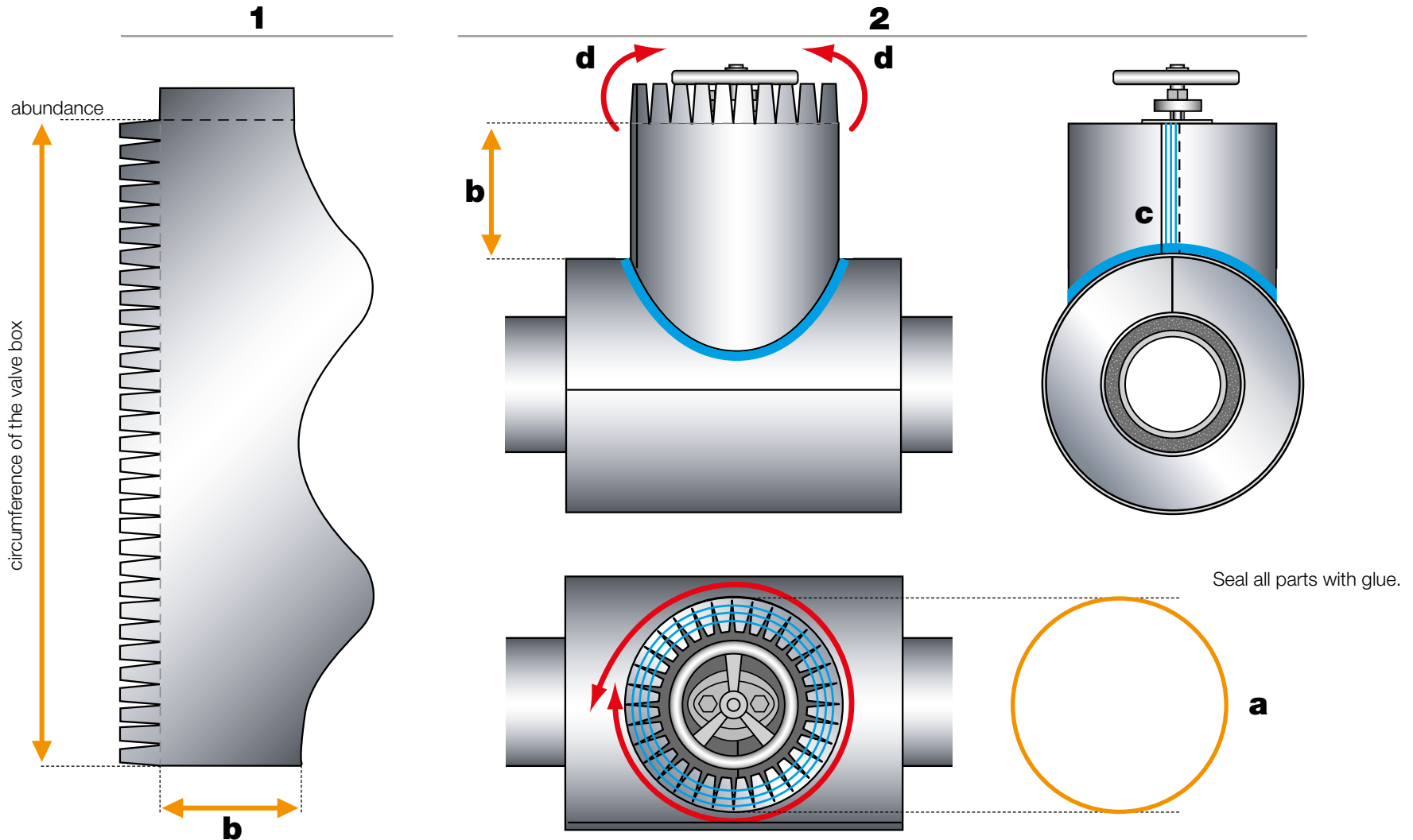

MATERIALS



KEY



K 420 adhesive

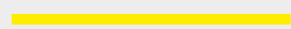

Marine sealant

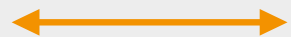

Measurements



Actions

K-FLEX® IN CLAD - VALVES



COVERING OF VALVE WITH VALVE BOX FACING UPWARDS

- 1)** Take the indicated measurements (**a-b-c**) and cut out, from a section of IN CLAD sheet, the shape of the front disk of the valve box. Make an opening cut (**d**) to allow for positioning.
- 2)** Fit the shape onto the front disk of the valve box and seal it down with the correct adhesive.

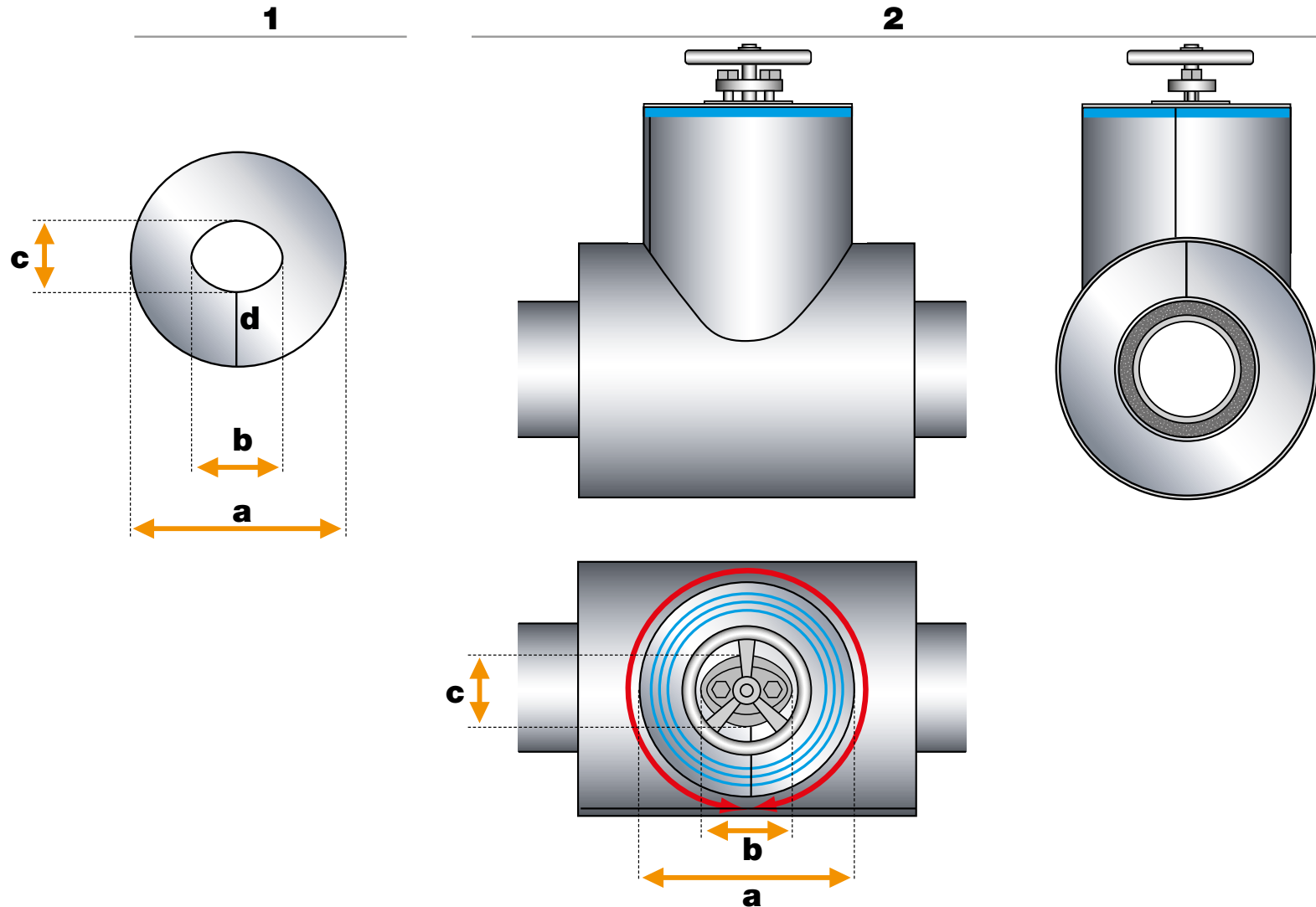

MATERIALS

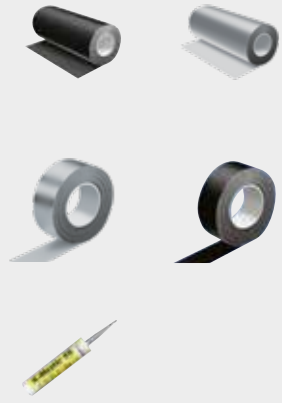

KEY



K 420 adhesive



Marine sealant



Measurements



Actions

K-FLEX® IN CLAD - VALVES



COVERING OF VALVE WITH VALVE BOX FACING UPWARDS

- 1) Seal all joints with marine sealant.
- 2) If necessary, fix the joints with the specific IN CLAD tape, applied with adhesive.

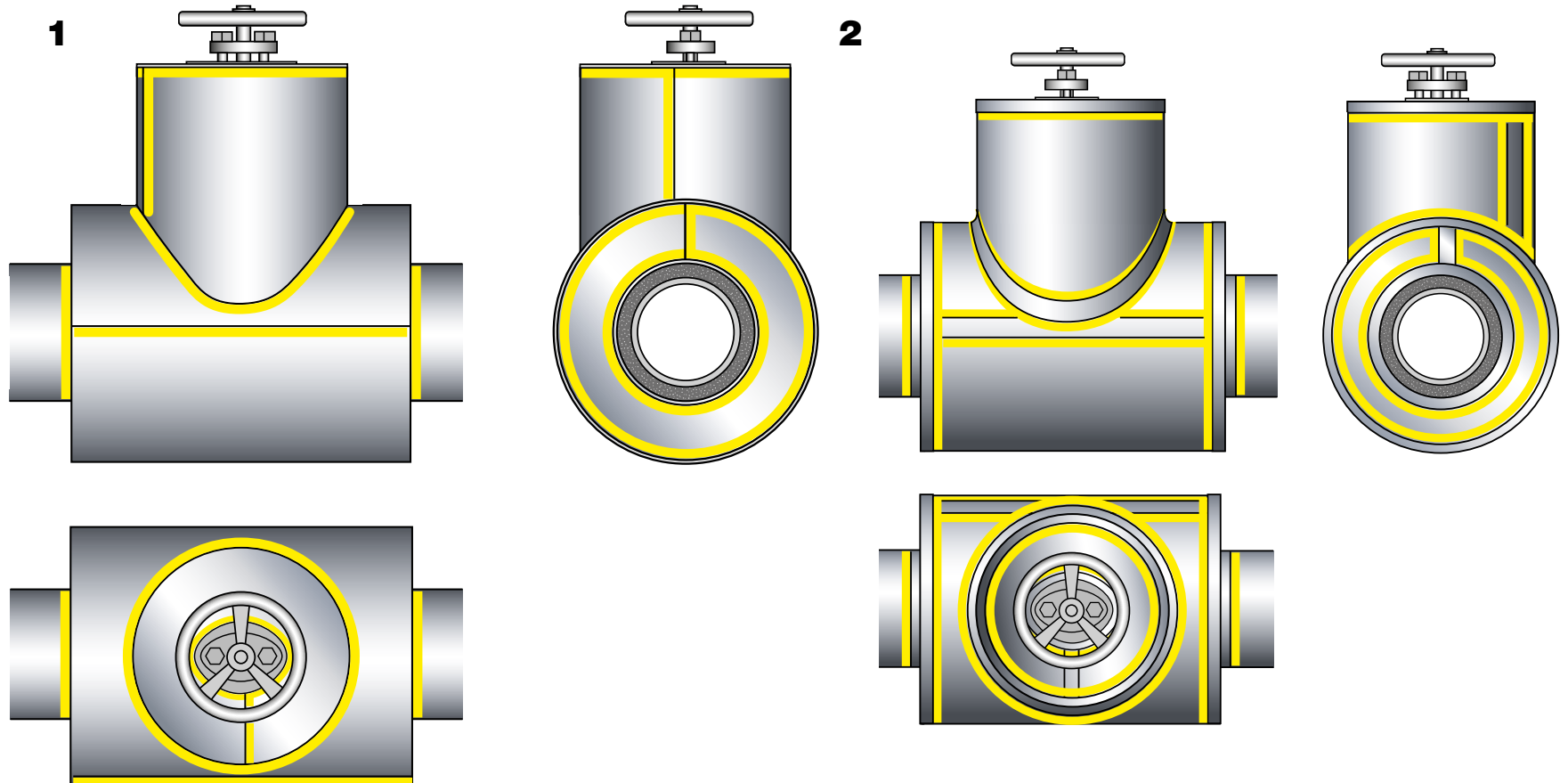

MATERIALS



K-FLEX® IN CLAD - VALVES



COVERING WITH PRE-SHAPED AND PRE-COVERED VALVE WITH IN CLAD SHEET

The pre-shaped K-FLEX® IN CLAD valve has an elastomeric body divided in two specular sections covered with IN CLAD sheet.

1) Glue the elastomeric edges along the dividing cut.

KEY



K 420 adhesive



Marine sealant

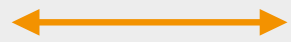

Measurements



Actions

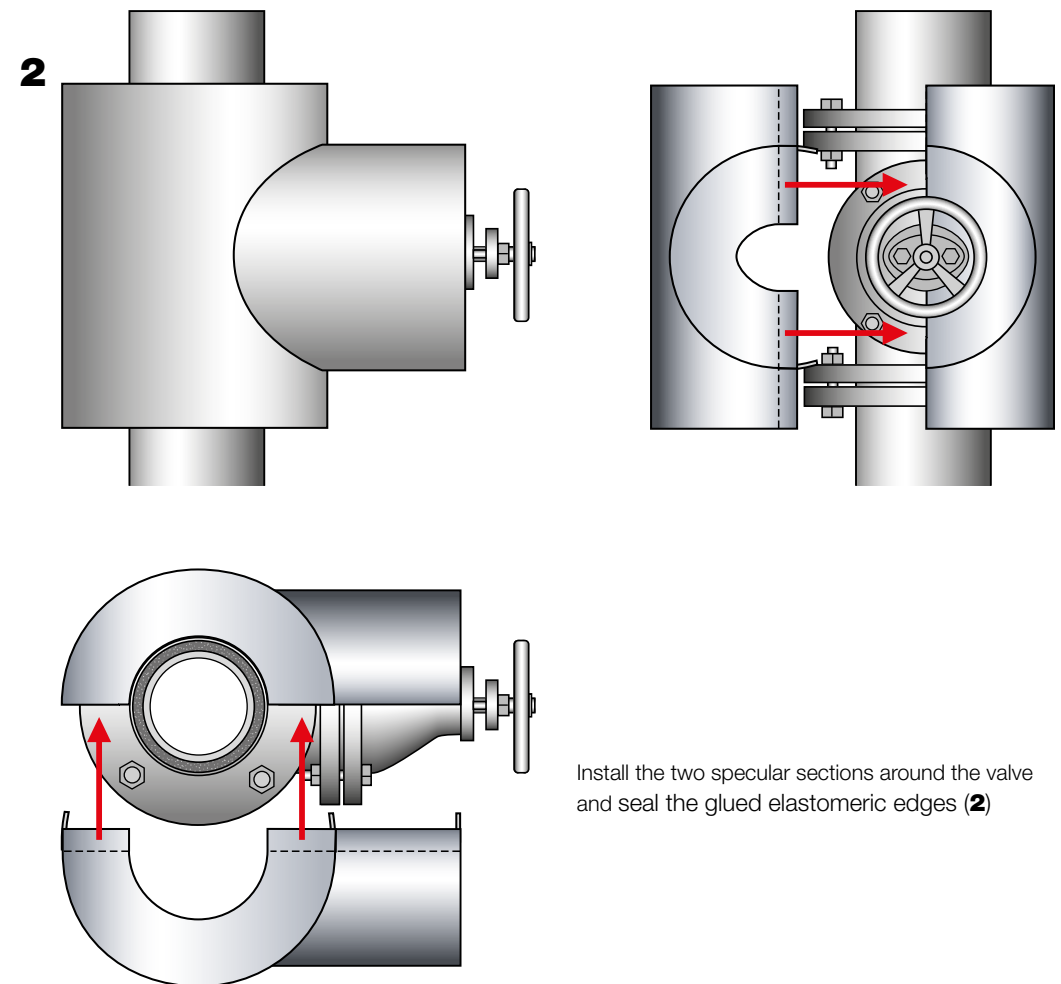
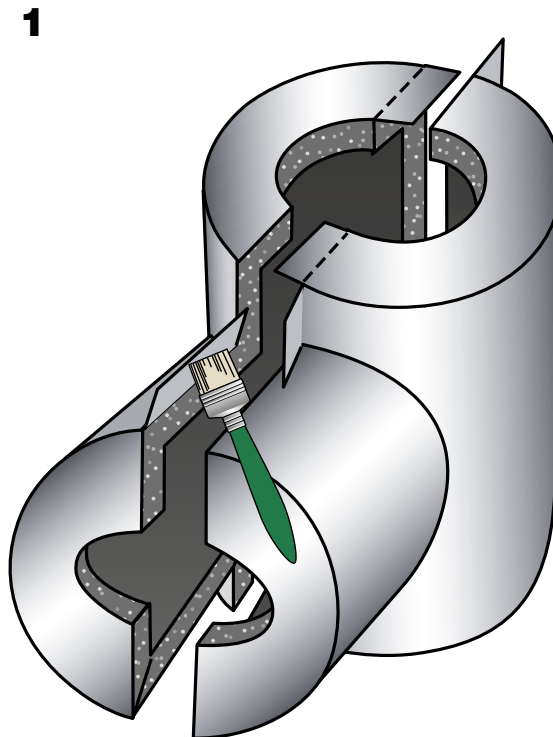

Install the two specular sections around the valve and seal the glued elastomeric edges (**2**)

MATERIALS

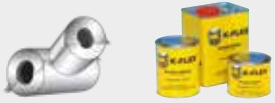

KEY



K 420 adhesive

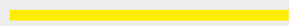

Marine sealant



Measurements



Actions

K-FLEX® IN CLAD - VALVES



COVERING WITH PRE-SHAPED AND PRE-COVERED VALVE WITH IN CLAD SHEET

Seal all the joints, including those of the pre-shaped part **(1)**.

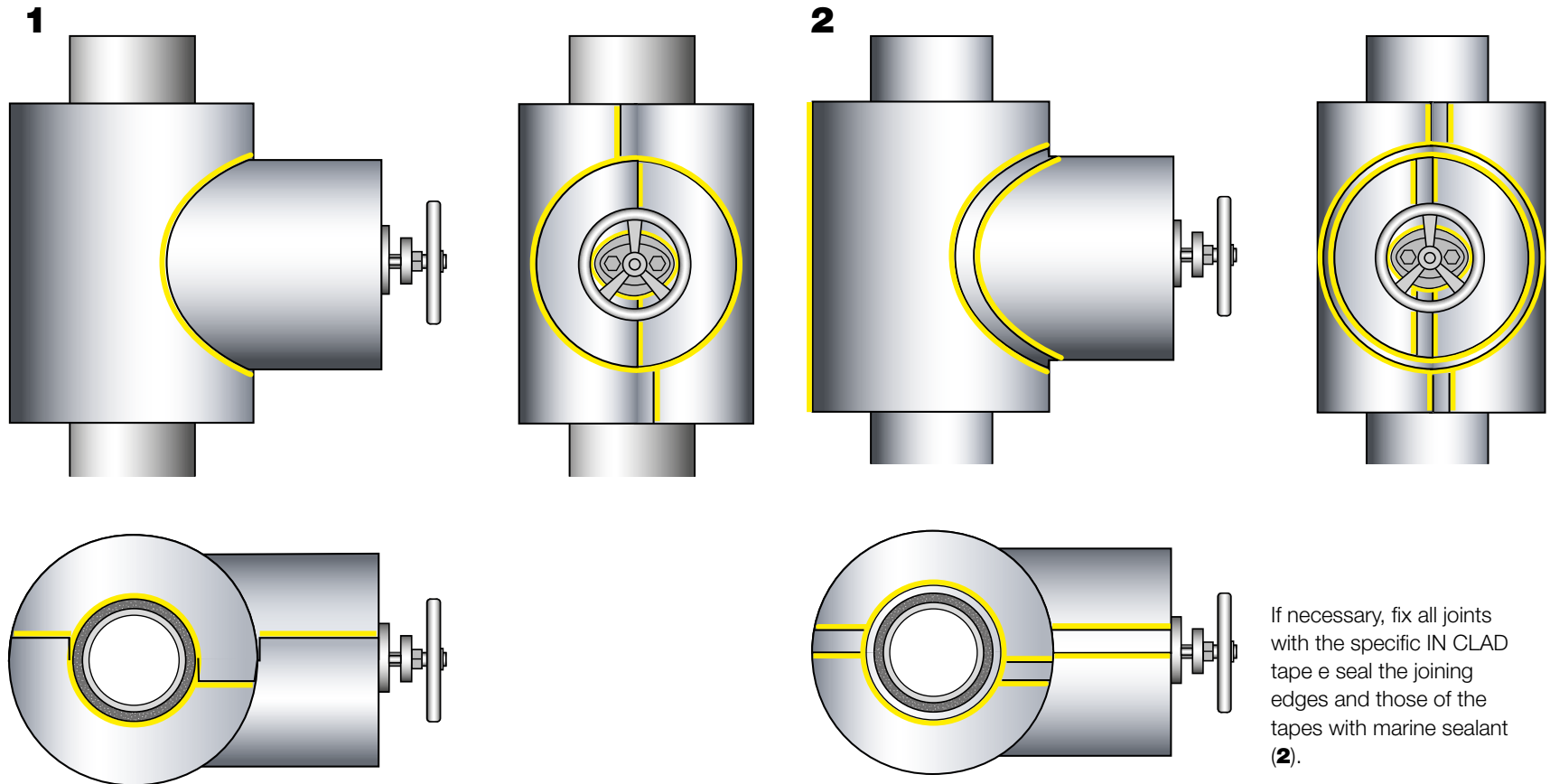

K-FLEX® IN CLAD REDUCERS

In the application sequence the **IN CLAD IG (Grey)** finishing is represented. The indications are also the same for the use of **IN CLAD IB (Black)** finishing.



For the application procedures of K-FLEX® insulating prepared by the installer with sheet sections, see the relevant sections of the K-FLEX® APPLICATION GUIDE

If you are not in possession of a printed guide you can ask for it at our technical dept. or download the PDF file from our website: www.kflex.com

MATERIALS



KEY



K 420 adhesive



Marine sealant



Measurements



Actions

K-FLEX® IN CLAD - REDUCERS

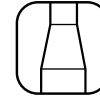

COVERING OF REDUCERS FACING UPWARDS

From three sections of IN CLAD sheet cut out the three sections needed to cover the reducer (**A1-2-3**), leaving an abundance of 5 cm for the overlapping of the joints. Sections **1-2** require indentations to help adherence to the respective upper section.

Cover the first section of piping (**B1**), sealing the joining edges with adhesive.

Cover the central section of the reducer (**C2**), sealing the joining edges with adhesive. Sections **C2** should overlap the indentations of sections **B1**.

Cover the upper section of the reducer (**D3**), sealing the joining edges with adhesive. Sections **D3** should overlap the indentations of sections **C2**.

Seal the joints with marine sealant (**E**).

It is important to closely follow the described installation sequence of the sections to face the overlaps against water.

If the specific IN CLAD tape is applied for covering joints, seal their edges with marine sealant.

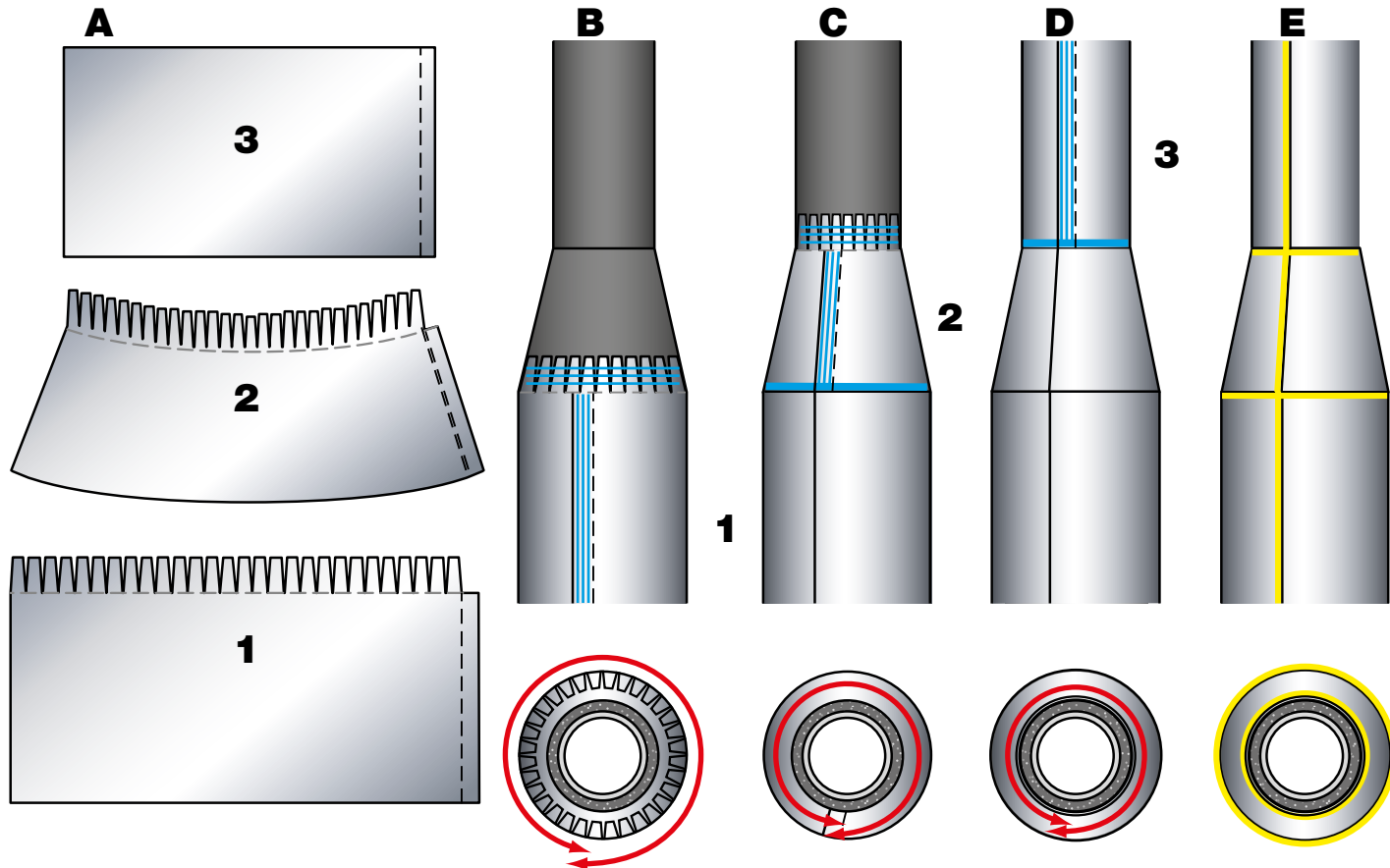

MATERIALS



KEY



K 420 adhesive

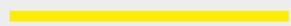

Marine sealant



Measurements



Actions

K-FLEX® IN CLAD - REDUCERS

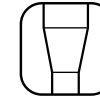

COVERING OF REDUCERS FACING DOWNWARDS

From three sections of IN CLAD sheet cut out the three parts needed to complete the reducer (**A1-2-3**), leaving an abundance of 5 cm for the overlapping of the joining edges. Parts **1-2** need the indentation to cling to the respective upper part.

Finish off the first section of piping (**B1**) fixing the joining edges with adhesive.

Finish off the central section of the reducer (**C2**) fixing the joining edges with adhesive. Part **2** overlaps the indentation of part **1**.

Finish off the upper section of the reducer (**D2**) fixing the joining edges with adhesive. Part **3** overlaps the indentation of part **2**.

Seal the joints with marine sealant (**E**).

It is important to closely follow the described installation sequence of the parts to face the overlaps against water.

If the specific IN CLAD tape is applied for covering joints, seal their edges with marine sealant.

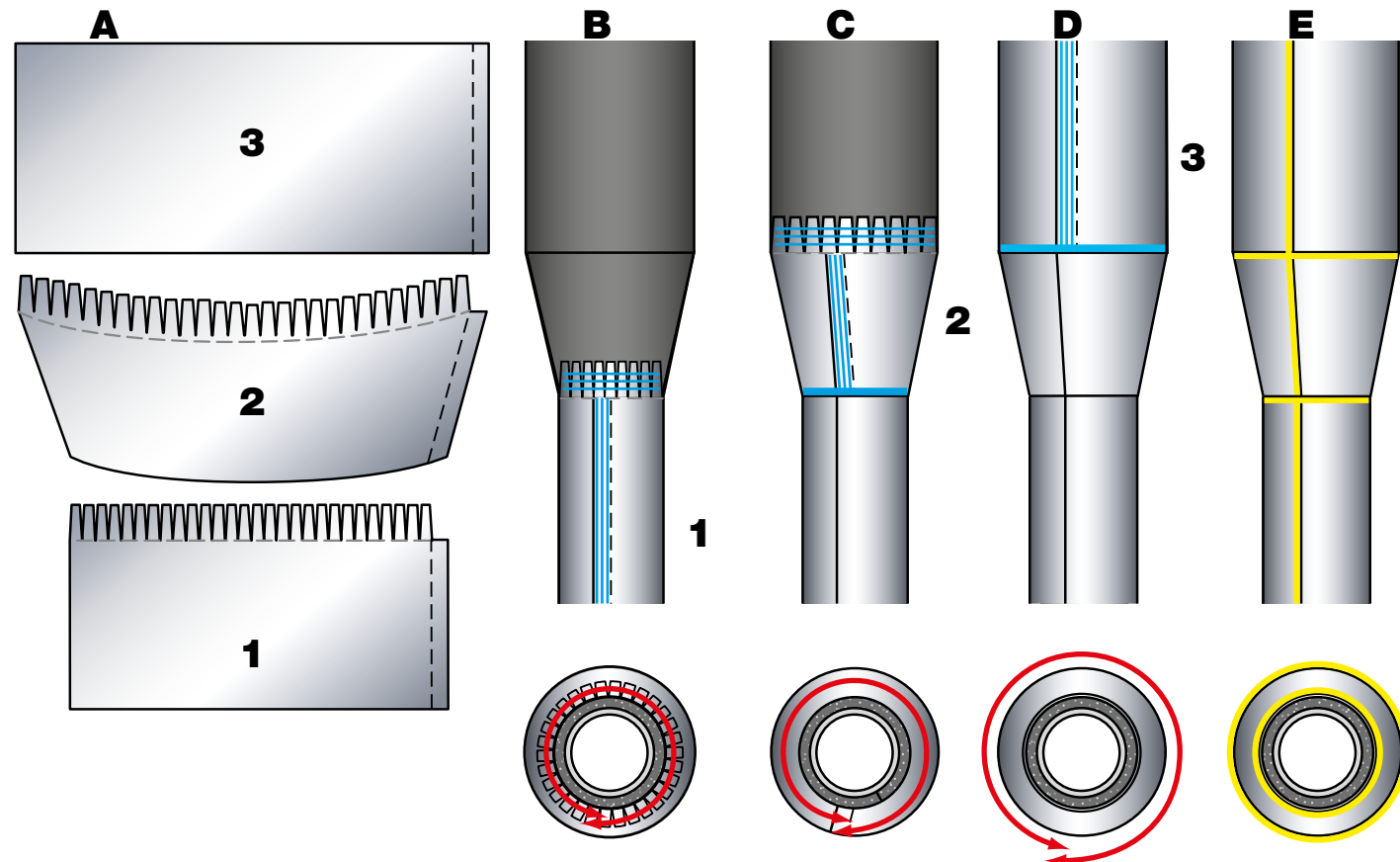

K-FLEX® IN CLAD

SMALL AND MEDIUM TANKS

In the application sequence the **IN CLAD IG (Grey)** finishing is represented. The indications are also the same for the use of **IN CLAD IB (Black)** finishing.



For the application procedures of K-FLEX® insulating prepared by the installer with sheet sections, see the relevant sections of the K-FLEX® APPLICATION GUIDE

If you are not in possession of a printed guide you can ask for it at our technical dept. or download the PDF file from our website: www.kflex.com

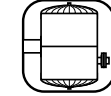

MATERIALS



KEY



K 420 adhesive

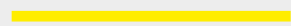

Marine sealant

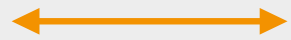

Measurements



Actions

K-FLEX® IN CLAD - SMALL AND MEDIUM TANKS

INSULATION WITH SECTIONS OF K-FLEX® ELASTOMERIC SHEET

A) Trace the shape corresponding to the size of the tank's curved base, subdividing it into the appropriate amount of segments.

Don't forget to create in the central hole for the waste pipe. Trace the section of a single segment in full-size scale, 1:1 (**a1**). Leave a sufficient abundance on the outer edge (**a2**) to accommodate the roundness of the base.

B) Cut out many segments of K-FLEX® sheet, enough to complete the covering of the base, and fix them on the tank with K 420 adhesive (**b1**).

With the same adhesive, seal the joints between one segment and another.

If necessary, cut out and apply a joining ring around the waste pipe, with elastomeric material (**b2**).

C) Repeat the operation for the insulation of the cover, taking into consideration any possible differences compared to the base.

The insulation of the accessories on the tank can be carried out before or after the covering of the walls. The installer will decide based on his own experience.

The accessories, usually of a cylindrical shape, are insulated with appropriate sections of K-FLEX® sheet cut to size and applied with K 420 adhesive.

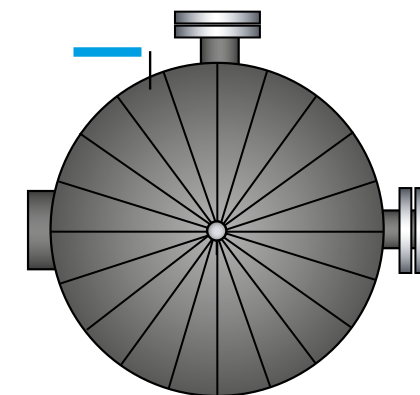
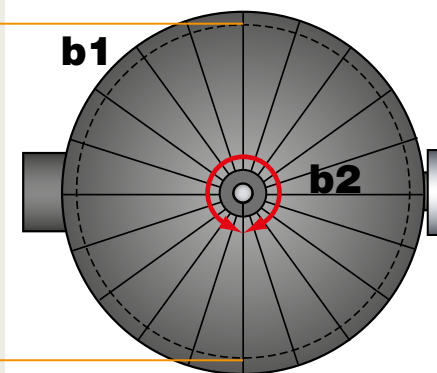
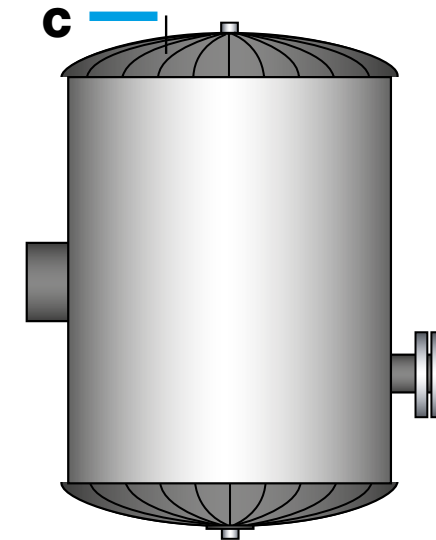
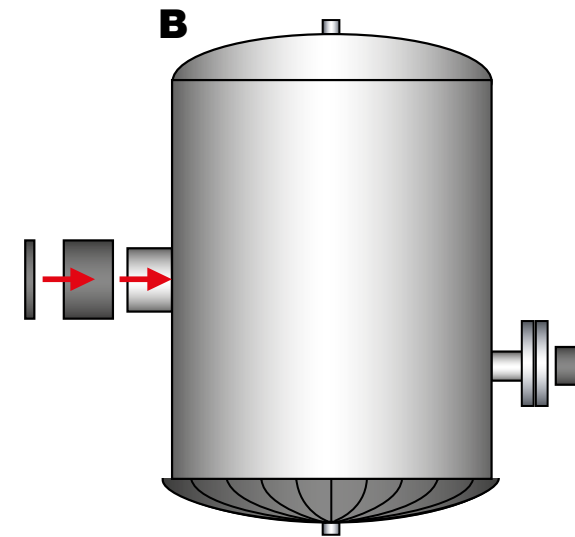
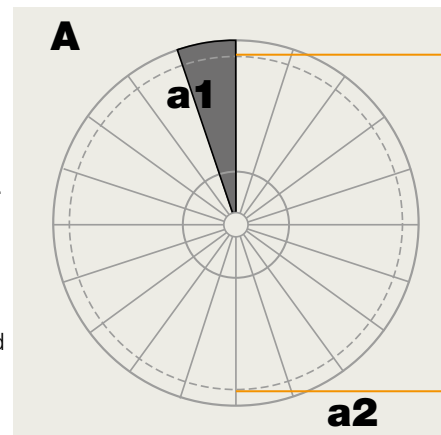

MATERIALS



KEY



K 420 adhesive



Marine sealant



Measurements



Actions

K-FLEX® IN CLAD - SMALL AND MEDIUM TANKS

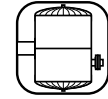

INSULATION WITH SECTIONS OF K-FLEX® ELASTOMERIC SHEET

From a K-FLEX® sheet cut out the sections to cover the tank's wall (**1-2**), leaving an opening for the accessories.

Apply the sections around the wall of the tank sealing them with K 420 adhesive. With the same adhesive also seal the joining edges between the sections.

Using K 420 adhesive, seal the joints between the segments (of the base and cover) and the sheet sections applied to the wall.

Pay great attention to the joints. A precise job without distortions during insulation will prove invaluable when the IN CLAD covering is installed.

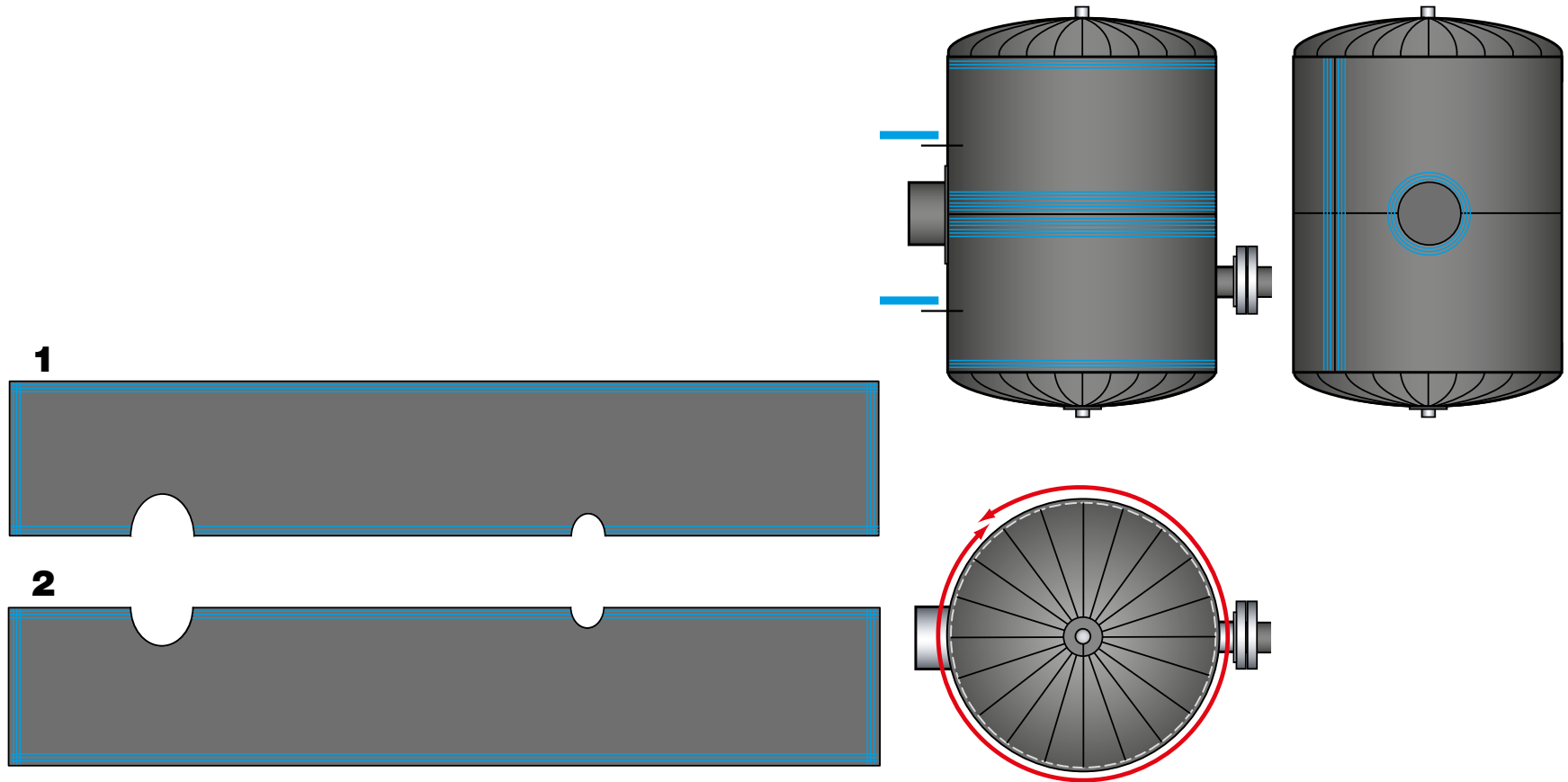

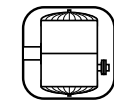

MATERIALS



KEY



K 420 adhesive



Marine sealant

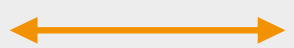

Measurements



Actions

K-FLEX® IN CLAD - SMALL AND MEDIUM TANKS

COVERING WITH SECTIONS OF IN CLAD SHEET

A) Trace the shape corresponding to the size of the tank's curved base, subdividing it into the correct amount of segments. Don't forget to create a central hole for the waste pipe. Leave an abundance on the outer edges large enough to attach the segments to the wall of the tank (**a1**). Trace the section of a single segment with the correct abundance to allow overlapping of the joint (**a2**). Cut out many segments of IN CLAD sheet, enough to cover the base.

B) Apply the segments on the insulation, and seal them together with their overlaps with the correct adhesive (**b1**).

C) Also apply the covering onto the joining ring around the waste pipe.

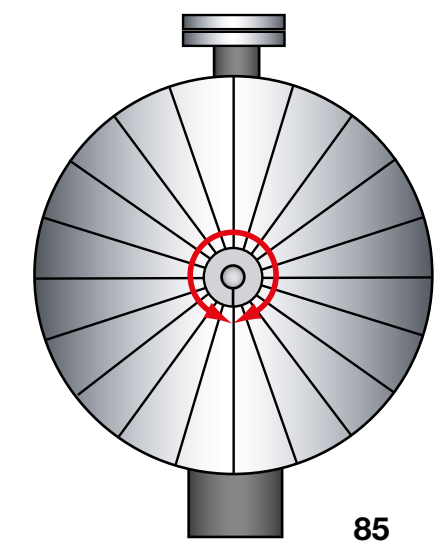
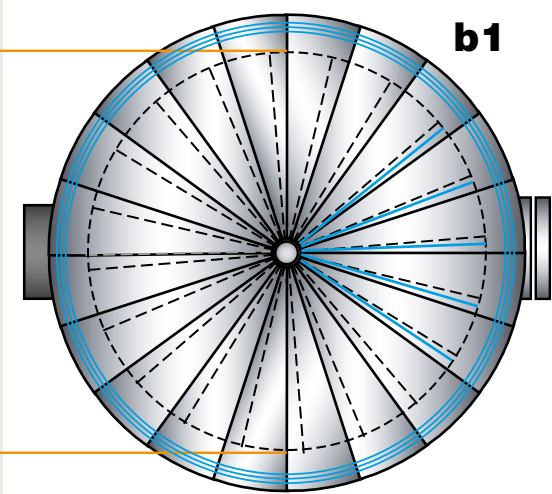
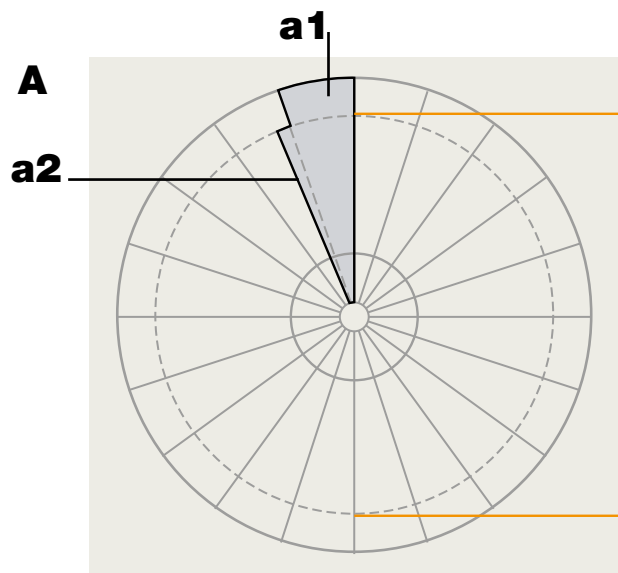
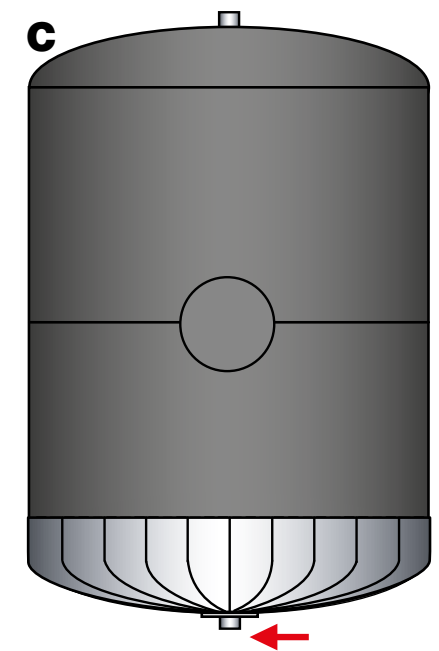
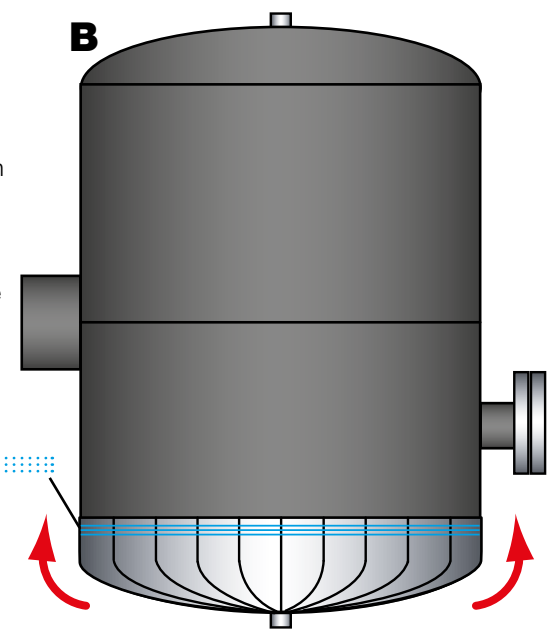

MATERIALS



KEY



K 420 adhesive



Marine sealant

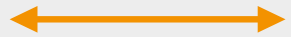

Measurements



Actions

K-FLEX® IN CLAD - SMALL AND MEDIUM TANKS

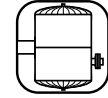

COVERING WITH SECTIONS OF IN CLAD SHEET

Insulation of the accessories

From a K-FLEX® IN CLAD sheet, cut out the sections of sheet A-B to cover the accessories on the wall of the tank.

All sections should be sealed with the correct adhesive.

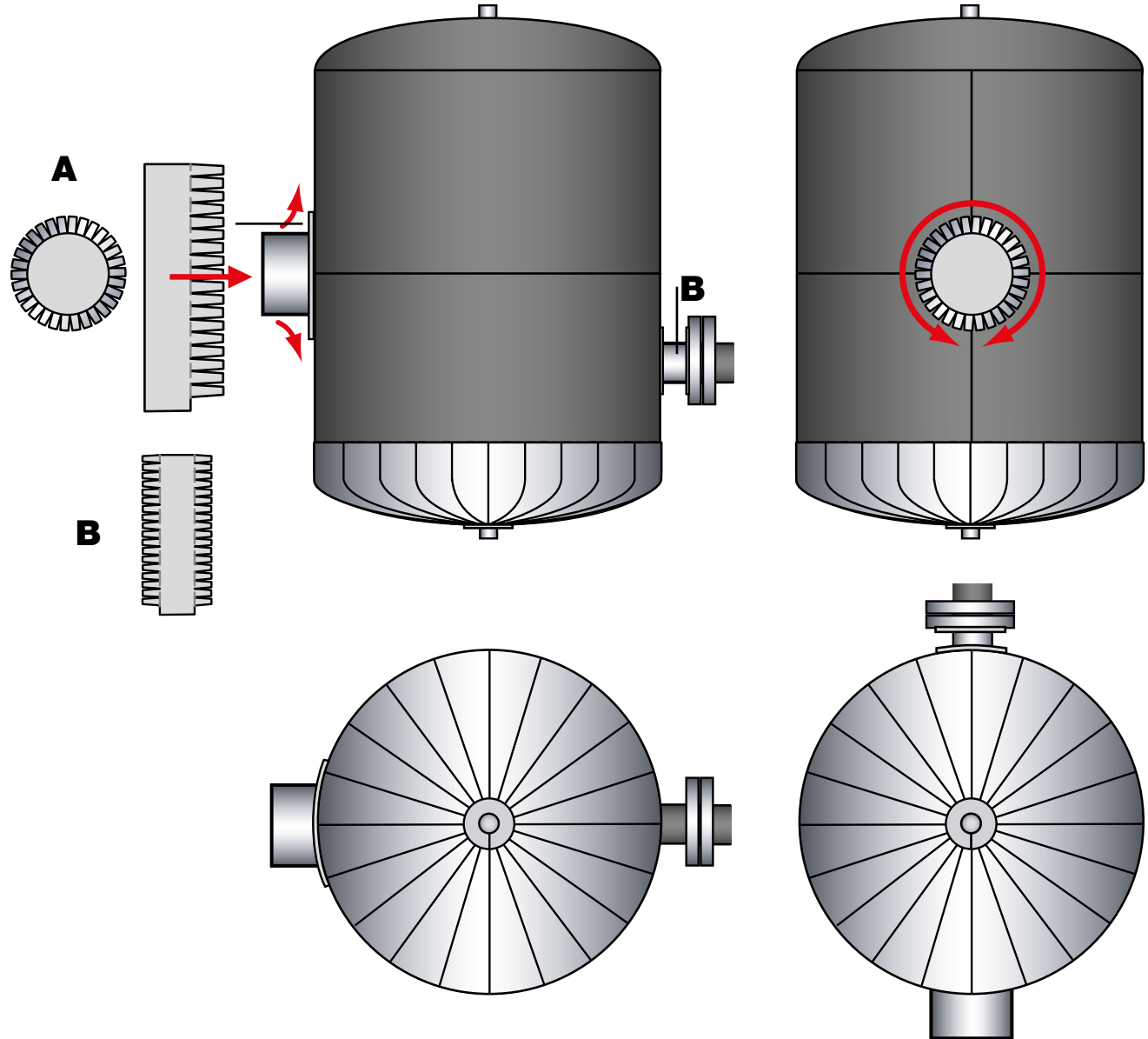

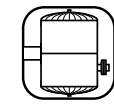

MATERIALS



KEY



K 420 adhesive

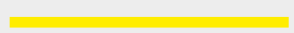

Marine sealant



Measurements



Actions

K-FLEX® IN CLAD - SMALL AND MEDIUM TANKS

COVERING WITH SECTIONS OF IN CLAD SHEET

From an IN CLAD sheet, cut out the sections to cover the tank's wall, leaving the appropriate abundance to allow for overlapping of the joints and the openings for the accessories which have already been insulated.
 Apply the sections around the wall, re-covering the indentations of the accessories' cover.
 Seal the edges and the overlaps with the correct adhesive.

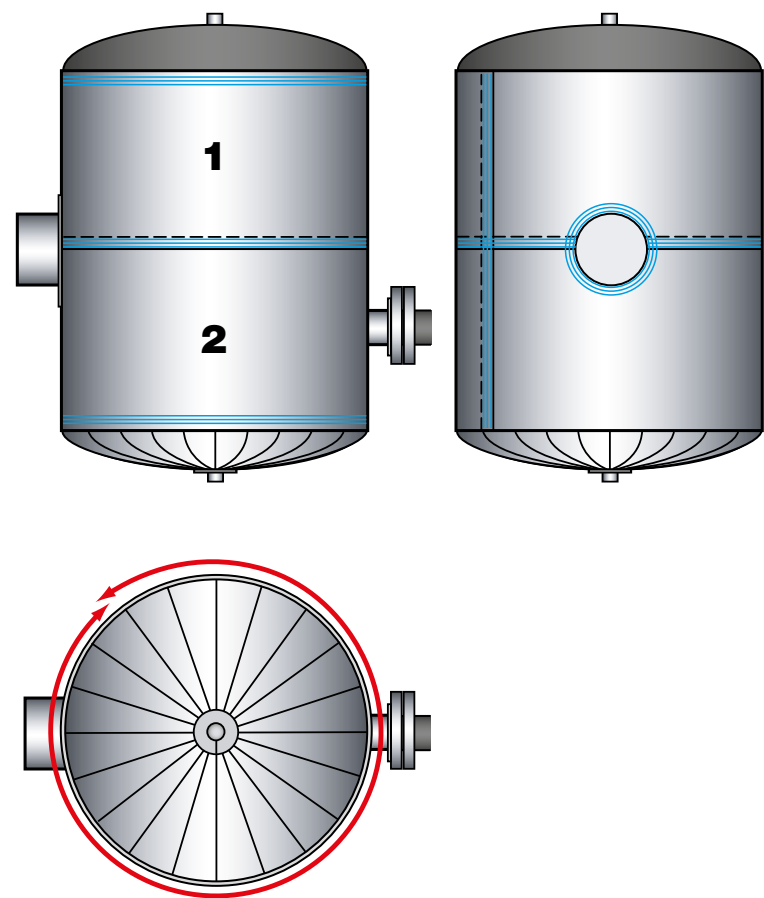
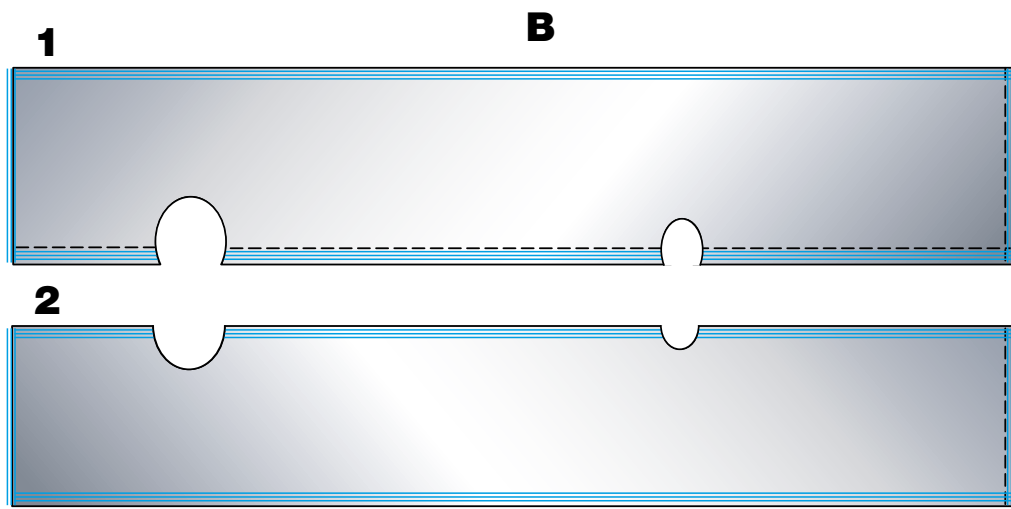

MATERIALS



KEY



K 420 adhesive



Marine sealant



Measurements



Actions

K-FLEX® IN CLAD - SMALL AND MEDIUM TANKS

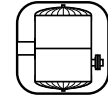

COVERING WITH SECTIONS OF IN CLAD SHEET

As previously illustrated for the base of the tank, prepare the segments of IN CLAD sheet needed for the cover. Apply the segments with adhesive, folding the abundance over the covering of the wall. Complete the operation with the joining ring positioned around the vent-hole. Also the tube should be covered, remembering to turn the joints away from the flow of water.

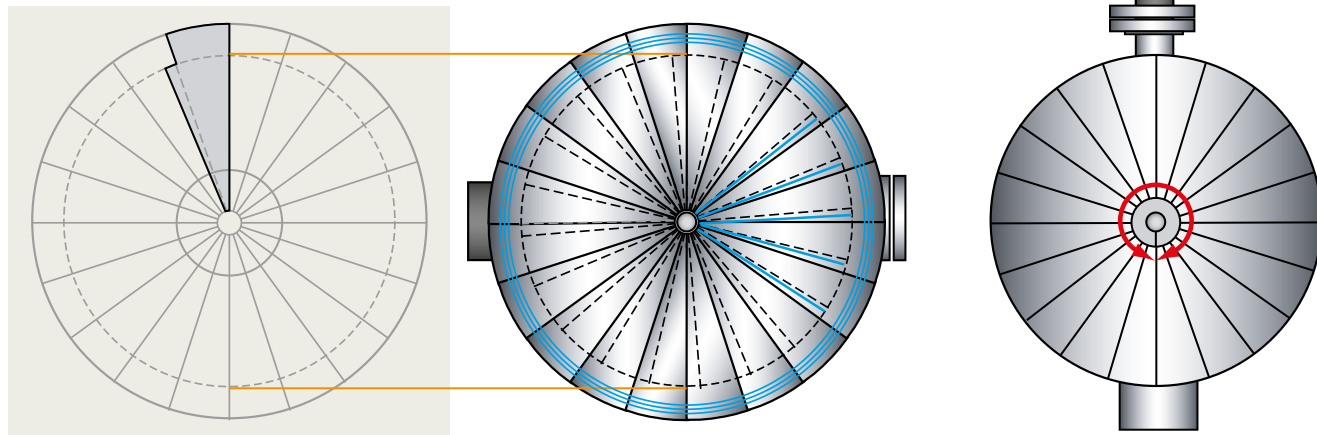
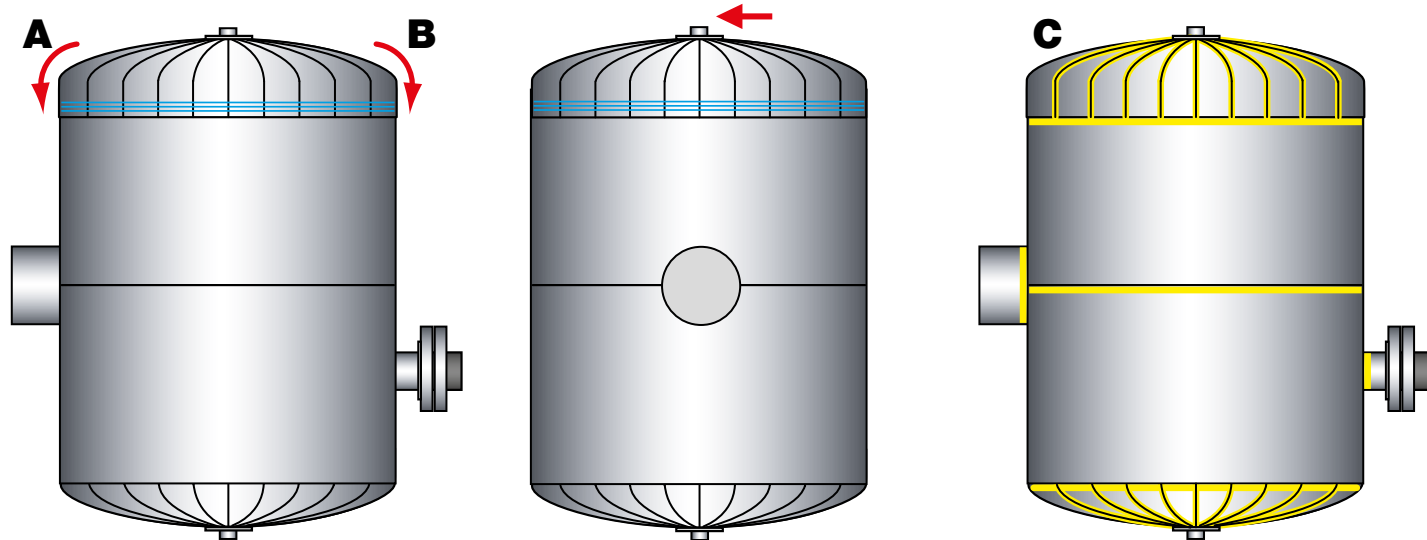

If necessary, seal the joints with the specific IN CLAD tape secured with glue. Fix the joining edges with marine sealant (C).

K-FLEX® IN CLAD LARGE TANKS

In the application sequence the finishing is represented. The indications are also the same for the use of **IN CLAD IB (Black)** finishing.



For the application procedures of K-FLEX® insulating prepared by the installer with sheet sections, see the relevant sections of the K-FLEX® APPLICATION GUIDE

If you are not in possession of a printed guide you can ask for it at our technical dept. or download the PDF file from our website: www.kflex.com

MATERIALS



KEY



K 420 adhesive



Marine sealant



Measurements



Actions

K-FLEX® IN CLAD - LARGE TANKS



INSULATION WITH SECTIONS OF K-FLEX® ELASTOMERIC SHEET

Insulation of the tank's wall

For the insulation of a large external tank, use K-FLEX® elastomeric sheets (of 1 m in height), cut the lengths needed to exactly cover the circumference. (eg.: 40 sections of 1,5 m for a circumference of 60 m).

Before applying the insulation sheets it is wise to carefully clean the surface removing traces of dirt, grease and oil to ensure correct adhesion.

Place the sheet sections in a circular manner **(a)** starting from the bottom and working towards the top **(b)**.

Vary the arrangement of the vertical joints to absorb the expansion of the insulation more efficiently.

Apply the next ring of sheets only when the previous one is perfectly aligned and sealed.

The surface that comes into contact with the sheets should be glued with K 420 adhesive.

With the same adhesive, glue together the edges of the adjacent sheets.

Exert the correct amount of pressure on the edges, avoiding tension and distortions, to allow for correct adhesion and a more pleasing appearance.

At the top of the cylindrical wall apply sheets, cut to heights that correspond to the tank.

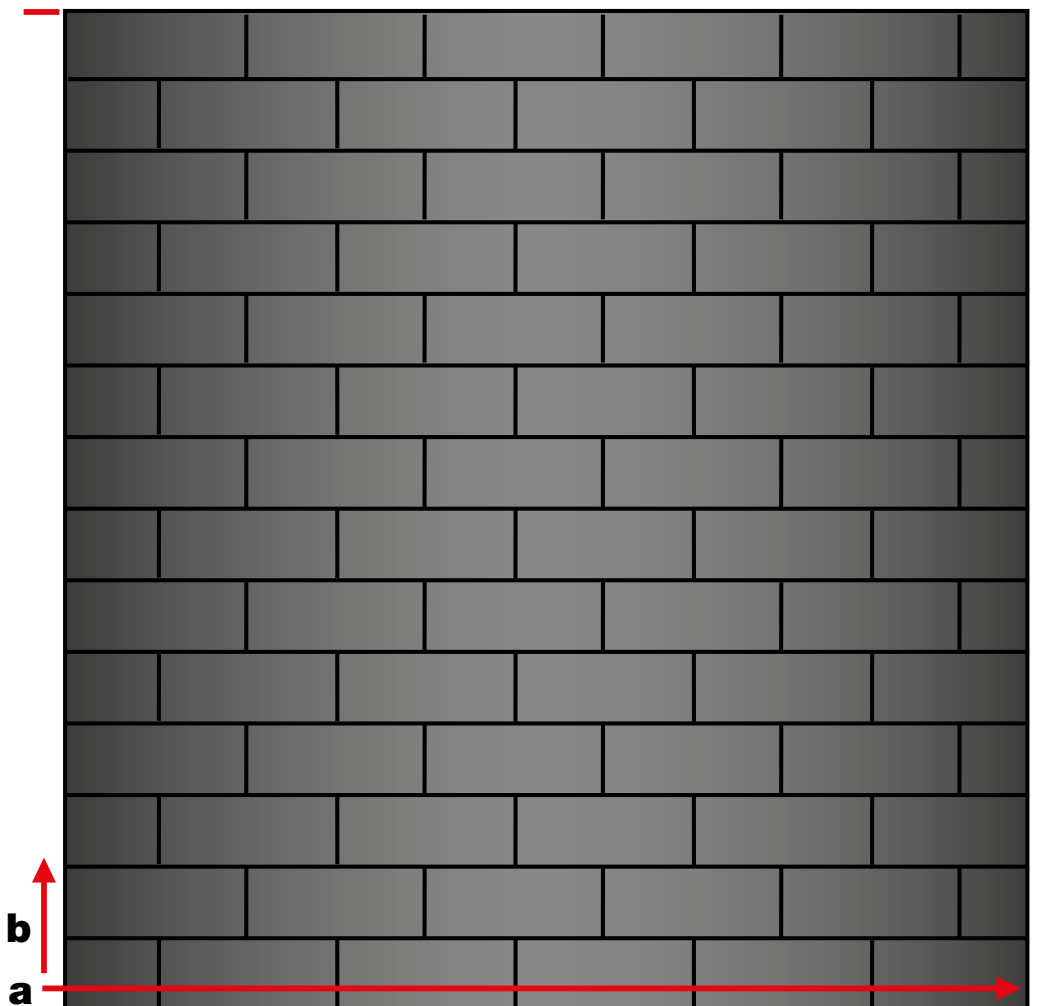

MATERIALS



KEY



K 420 adhesive



Marine sealant

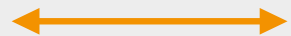

Measurements



Actions

K-FLEX® IN CLAD - LARGE TANKS

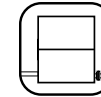

INSULATION WITH SECTIONS OF K-FLEX® ELASTOMERIC SHEET

Insulation of the tank's roof

For the covering to apply onto the roof of the tank, use sheets of 1 m (corresponding to that of the covering sheet) in order to cover the entire surface.

With careful planning (it is advisable to prepare a diagram to calculate the correct dimensions of the project) the elastomeric sheets can be placed in a practical way.

Place the K-FLEX® elastomeric sheets starting from the outer ring (**a**) towards the center. The rounded edges of the outer sections should follow the curve of the tank.

After having cleaned the surface of the tank, removing all traces of dirt, oil and grease to ensure a correct adhesion, apply the sheets.

Apply K 420 adhesive onto the surface which comes into contact with the sheets.

With the same adhesive, seal together the edges of the adjacent sheets.

Exert the correct amount of pressure on the edges, avoiding tension and distortions, to allow for correct adhesion with a more pleasing appearance.

To avoid detachments and infiltrations, the insulation of the tank's walls together with the perimetrical joints must be carefully sealed.

The insulation of the roof must overlap the perimetrical insulation.

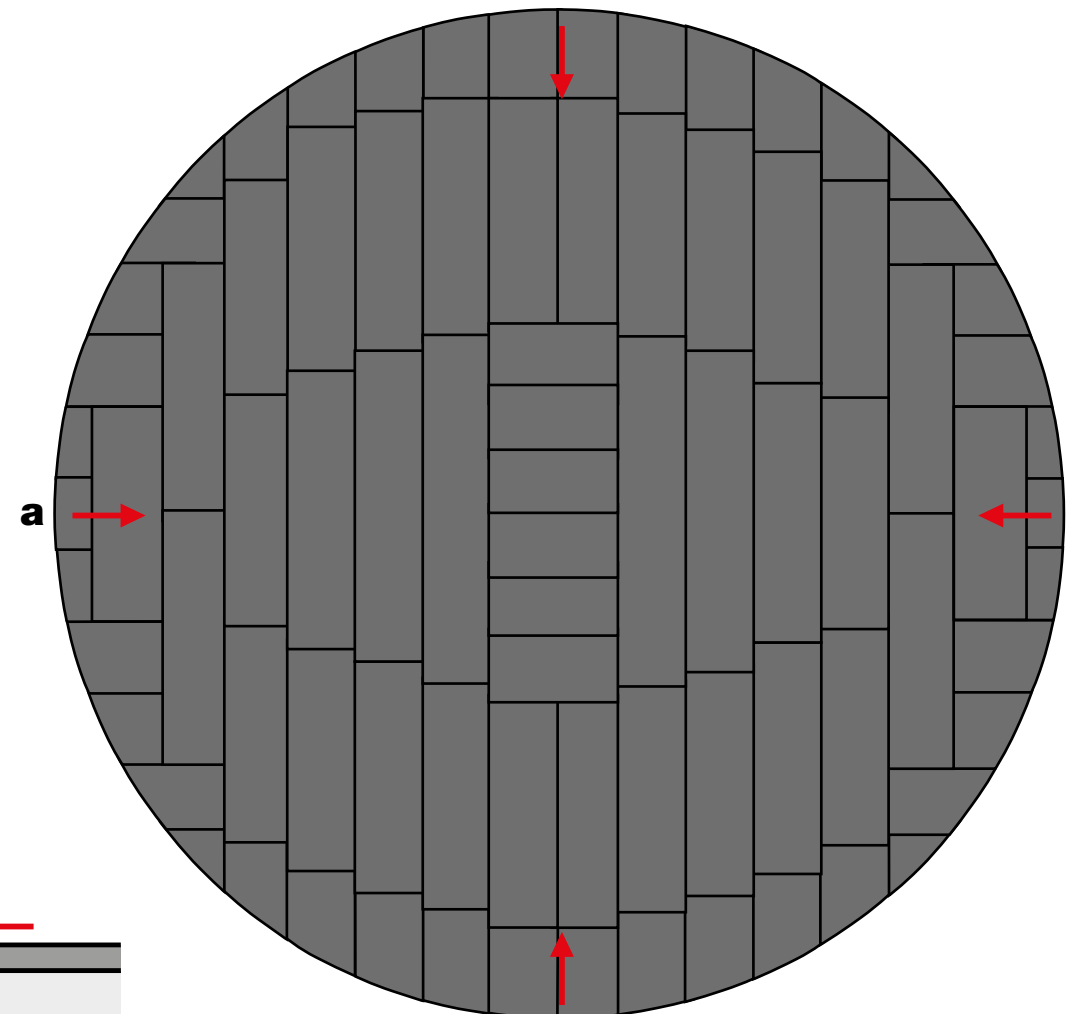

MATERIALS



KEY



K 420 adhesive

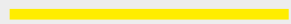

Marine sealant

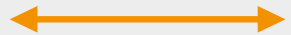

Measurements



Actions

K-FLEX® IN CLAD - LARGE TANKS

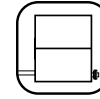

COVERING WITH IN CLAD SHEET

Covering the wall of the tank
For the covering of the tank, re-trace the plan of the elastomeric sheets already in position.

Take the measurements of the elastomeric sheets and cut out sections of corresponding IN CLAD sheets, leaving the correct abundance to allow for overlapping (**a**).

Apply the sheet sections in a circular manner (**c**) starting from the bottom and working up towards the top.

Apply the next ring of sheets only when the previous one is perfectly aligned and sealed.

Glue the joints with the correct adhesive.

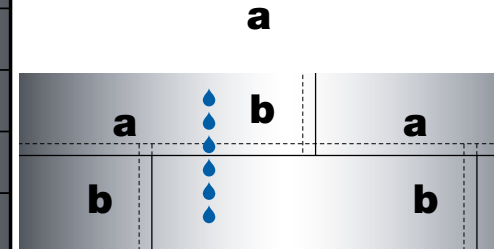
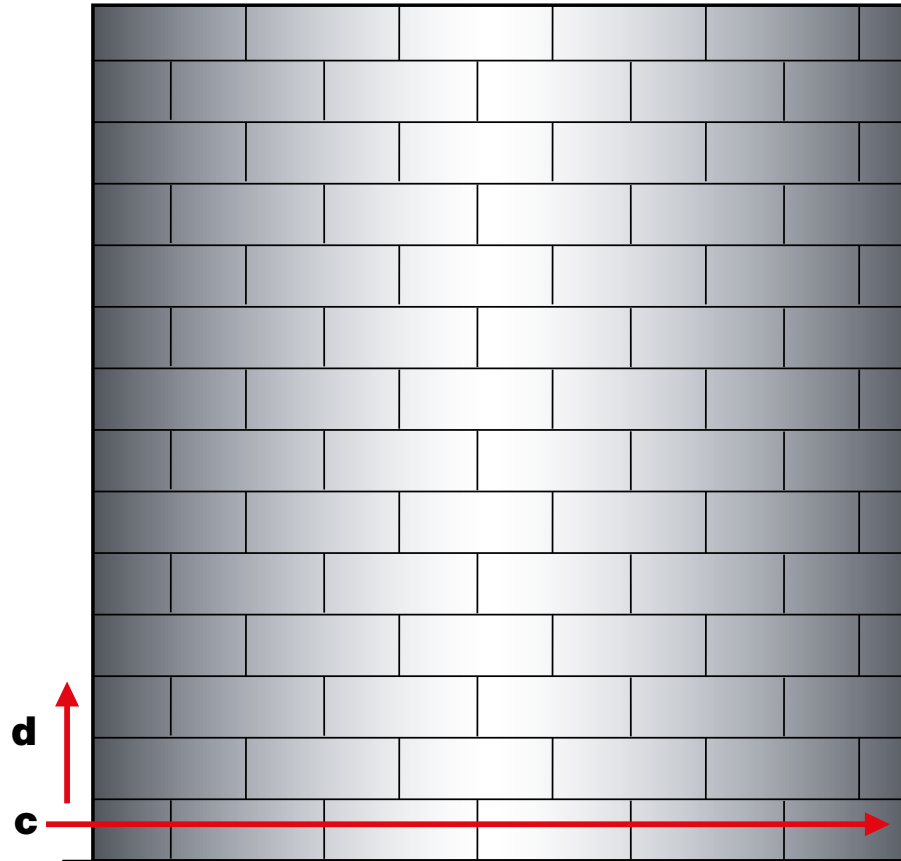
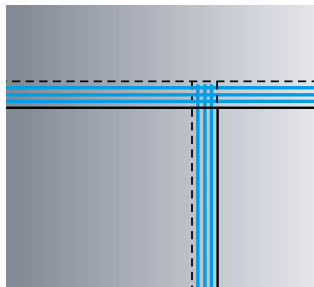

The overlapping of the excess should always be placed above the underlying sheet to allow water to flow above the joints (💧).
Leave an excess to allow for overlapping between horizontal adjacent sheets always on the same side to improve appearance (**b**).

MATERIALS



KEY



K 420 adhesive

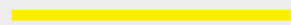

Marine sealant



Measurements



Actions

K-FLEX® IN CLAD - LARGE TANKS



COVERING WITH IN CLAD SHEET

Covering the top of the wall
 On the top of the wall an indentated ring must be applied to protect the edge with the roof of the tank **(B)**.

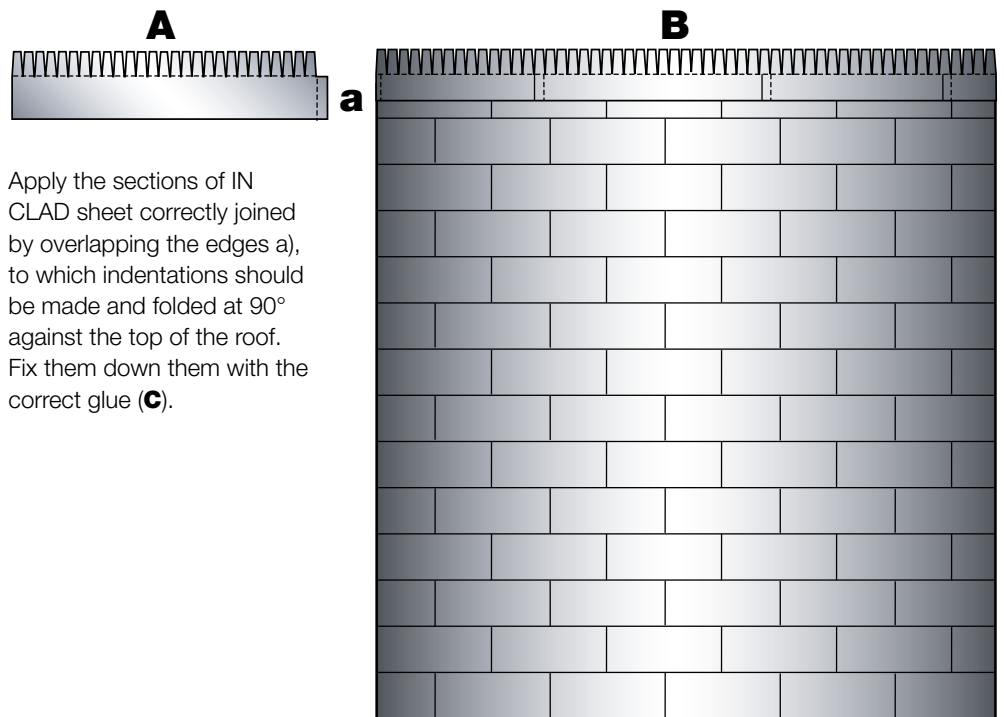

Apply the sections of IN CLAD sheet correctly joined by overlapping the edges **a)**, to which indentations should be made and folded at 90° against the top of the roof. Fix them down them with the correct glue **(C)**.

Calculate the number of IN CLAD sheet sections that will be used to complete the circumference of the tank **(C)**.

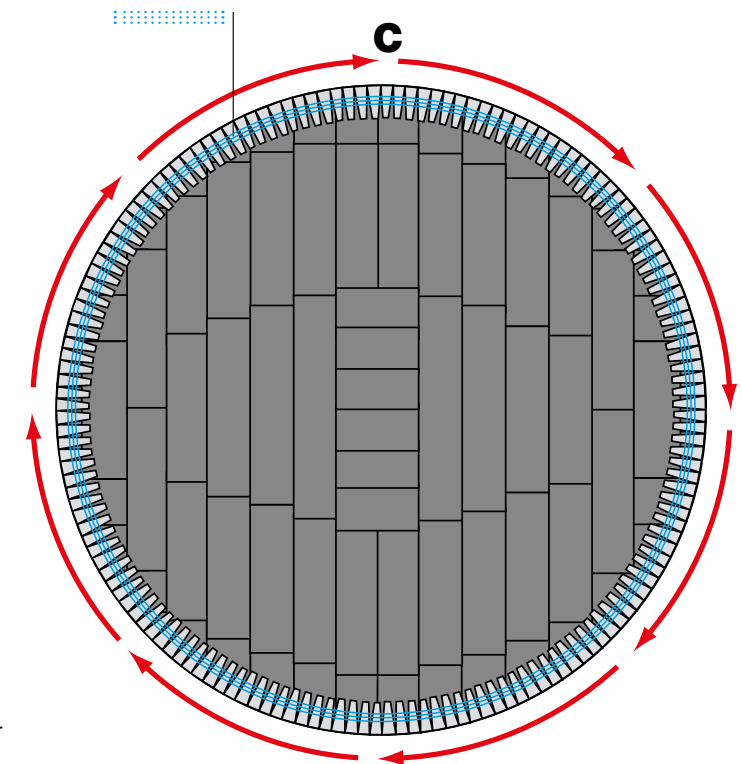

MATERIALS



KEY



K 420 adhesive



Marine sealant



Measurements



Actions

K-FLEX® IN CLAD - LARGE TANKS



COVERING WITH IN CLAD SHEET

Covering the roof of the tank

On the roof, cover each K-FLEX® elastomeric sheet, previously installed, with sections of IN CLAD sheet.

The example illustrated here shows how to cover the roof in a circular fashion, **a**) continuing gradually towards the center, continuously overlapping the joints of the sections in an orderly and functional manner to allow the water to flow from the centre of the roof towards the edges of the tank **b**).

For the covering of the tank's roof, retrace the pattern of the elastomeric sheets already installed. Take the measurements of the elastomeric sheets and cut the sections of the corresponding IN CLAD sheet, leaving the correct abundances for the overlapping **(a)**.

First place the outer sheet sections and then gradually proceed towards the center of the roof, overlapping each sheet to those placed before. In this way even the slightest difference in level of the overlappings will allow water to flow towards the outside (💧).

Fix the joints with adhesive.

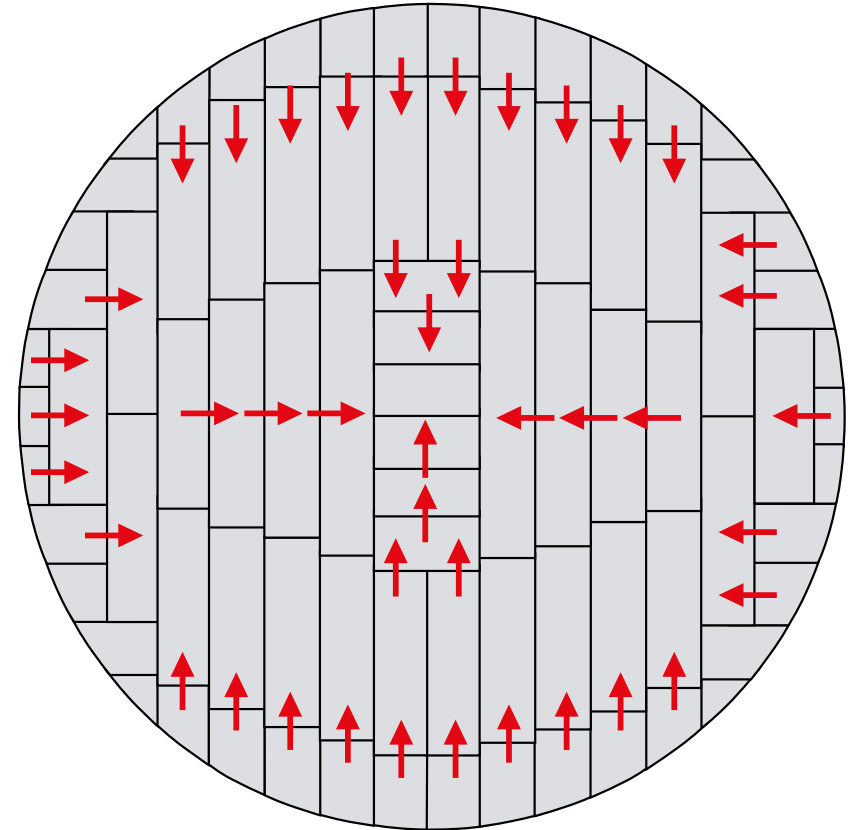
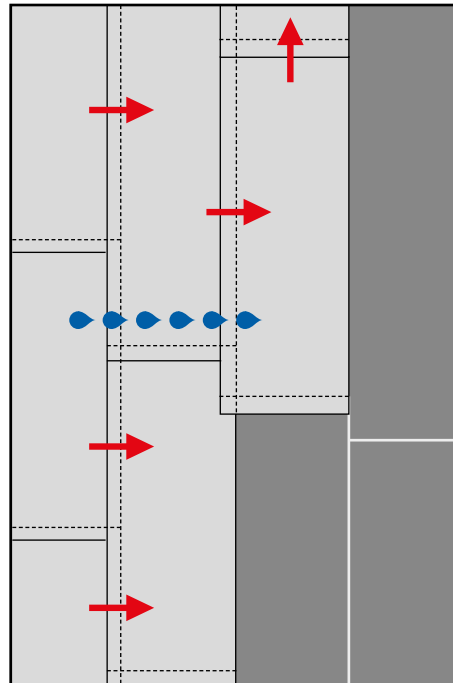

MATERIALS



KEY



K 420 adhesive



Marine sealant

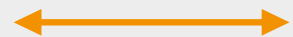

Measurements



Actions

K-FLEX® IN CLAD - LARGE TANKS

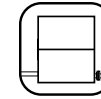

COVERING WITH IN CLAD SHEET

For the outer sheet sections it is necessary to protect also the thickness of the curved side with IN CLAD covering, folded towards the outside. To allow the flow of the water out of the perimetrical edge, an extra abundance must be added (**a**) including the thickness of the K-FLEX® sheet plus an extra 5/10 cm needed for an adequate overlapping of the sheet to the wall below (**b**). If necessary, make a cut in the overlap (**c**) to absorb the tension of the curve. Glue the overlap with the correct adhesive.

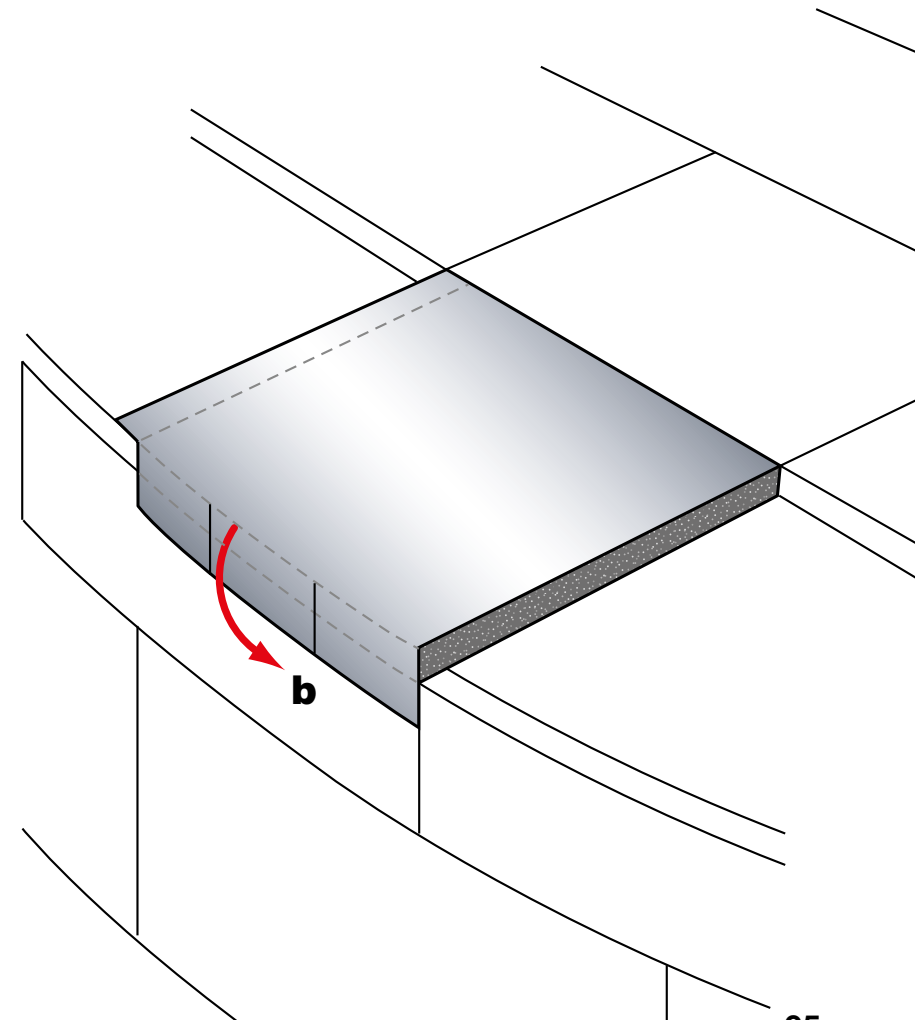
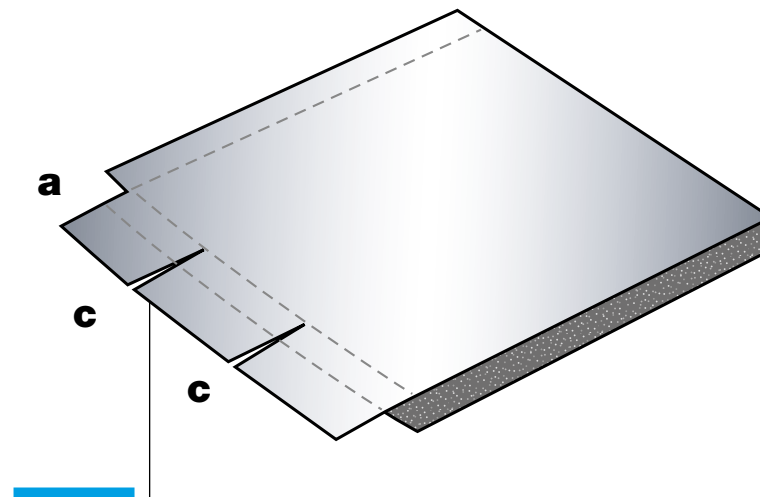

MATERIALS



KEY



K 420 adhesive



Marine sealant



Measurements



Actions

K-FLEX® IN CLAD - LARGE TANKS

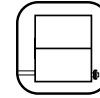

COVERING WITH IN CLAD SHEET

Accurately seal all the joints and the overlapping edges with marine sealant. If necessary, seal the joints with the specific IN CLAD tape secured with glue. The duration of the covering depends very much on the care with which this operation is initially carried out.

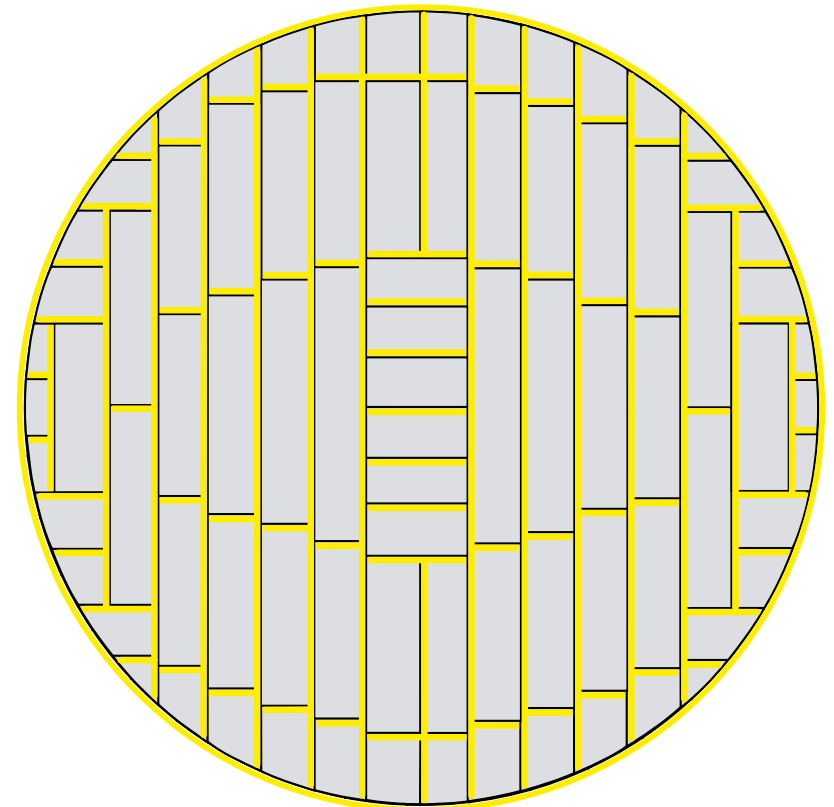
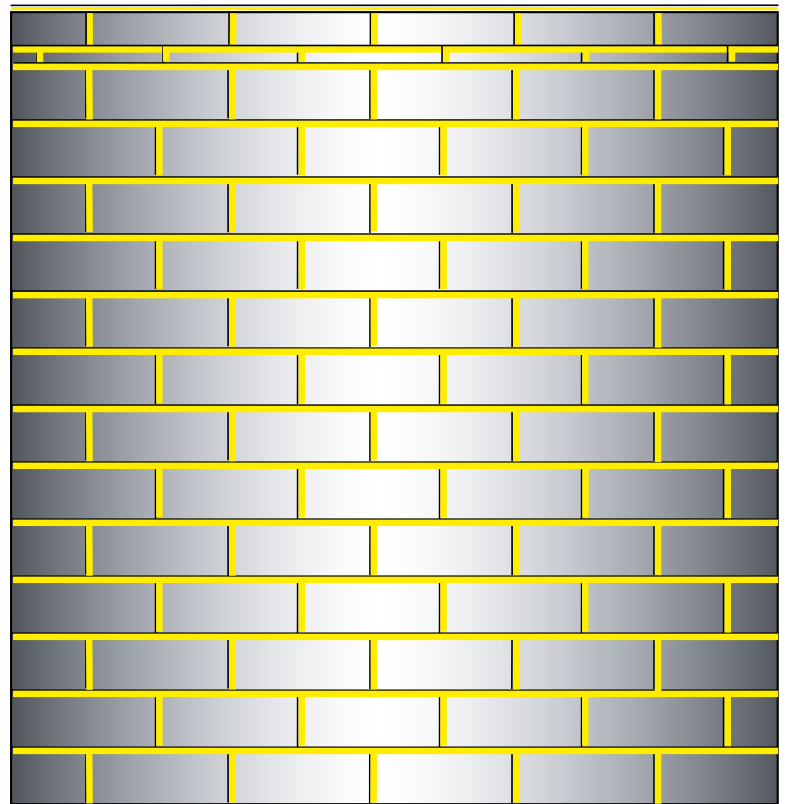

MATERIALS



KEY



K 420 adhesive



Marine sealant



Measurements



Actions

K-FLEX® IN CLAD - LARGE TANKS

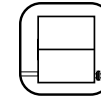

INSULATION AND COVERING WITH K-FLEX® ELASTOMERIC SHEET COVERED WITH IN CLAD SHEET

General indications for the application of K-FLEX® IN CLAD sheet onto large tanks:
On the large surfaces of the tanks, the use of sheet should be rationalized first of all according to its dimensions.

Since it is supplied in rolls of 1 m in height, the sheet should be used in sections of 1 m by X m in length.

It is advisable to keep the length to a size as to allow for easy manual control during installation.

Geometric precision is in fact of great importance whilst working, in order to maintain even alignment of the joined sections.

The overlaying of joints between the subsequent sections should always be prepared against water and in a pleasing aesthetic way to create a satisfying end result.

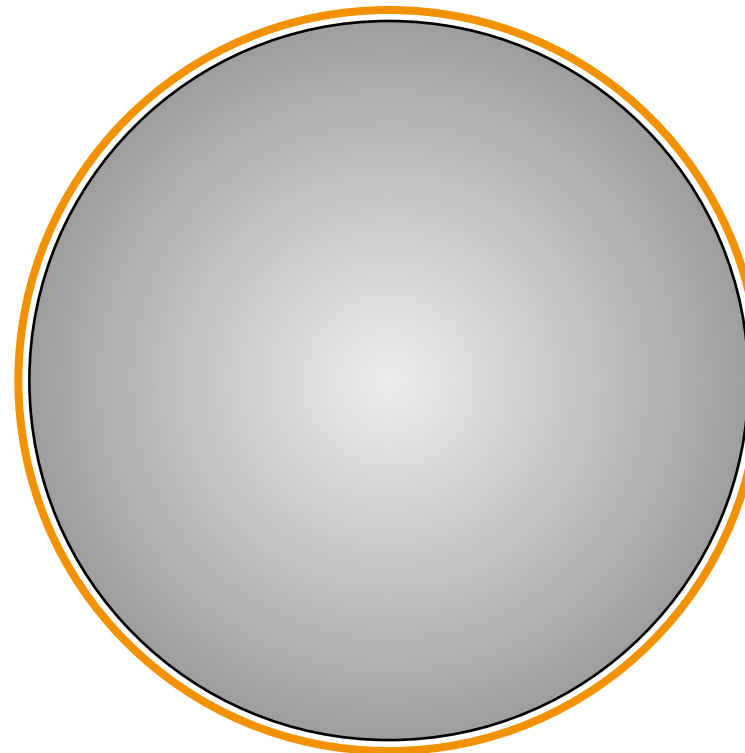

Dimensions should be exactly calculated
Decide how many sections of K-FLEX® IN CLAD sheet are needed to cover the circumference.
Example; for a circumference of 60 m (**a**) you need: 40 sections of 1,55 m (1,5 m working length + 5 cm od abundance).

K-FLEX® IN CLAD: CONTROLLING MATERIAL COSTS

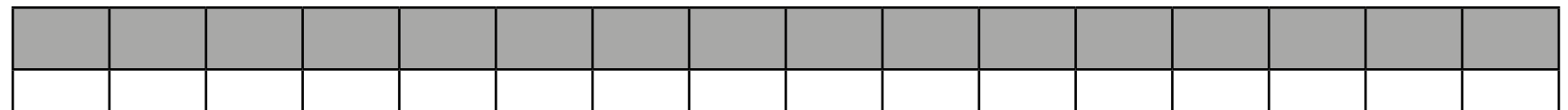

Another factor not to neglect is the remaining material produced from a roll of K-FLEX® IN CLAD sheet.

Insulation with K-FLEX® sheets, thanks to the adaptability of the material, always allows you the possibility to re-use the remaining material during a previous operation.
Example: from a roll of 20 m you can obtain 12 sections of 1,55 m with a left over of 1,40 m. This material can without doubt be used for the sections of covering for the roof of the tank which has different dimensions. At the end of the job, the remaining material will be very little.

MATERIALS



KEY



K 420 adhesive

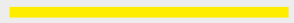

Marine sealant

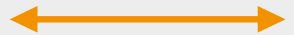

Measurements



Actions

K-FLEX® IN CLAD - LARGE TANKS

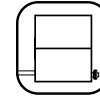

INSULATION AND COVERING WITH K-FLEX® ELASTOMERIC SHEET COVERED WITH IN CLAD SHEET

Covering the wall of the tank

For the covering of the tank's wall you need to prepare the sections of K-FLEX® IN CLAD to obtain an abundance of 5 cm to overlay the adjacent sections.

Prepare the abundances on the lower side and on the right of the sections (a-view from the side of the finishing).

Seen from the elastomer parts, the right part appears inverted (**b**).

Trace the two cutting lines on the elastomer and with a blade cut until making contact with the IN CLAD sheet.

Remove the elastomeric part (5 cm) from the sides of the relevant abundance and clean the sheet of the residuals. The operation is fairly easy and quick.

The section is now ready for application.

The sections of K-FLEX® IN CLAD must be applied onto the wall of the tank with K 420 adhesive



a

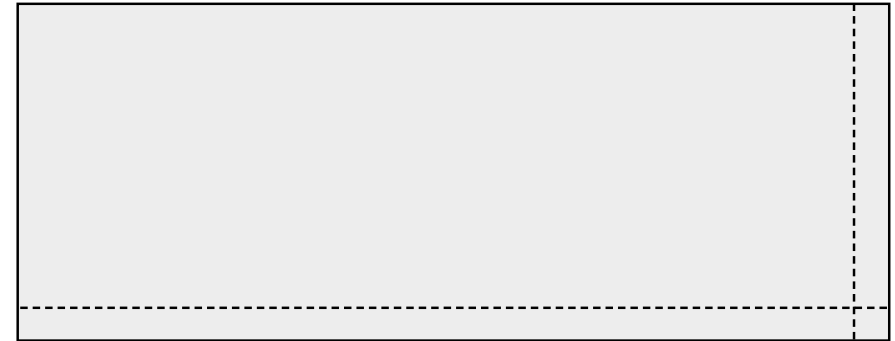

b

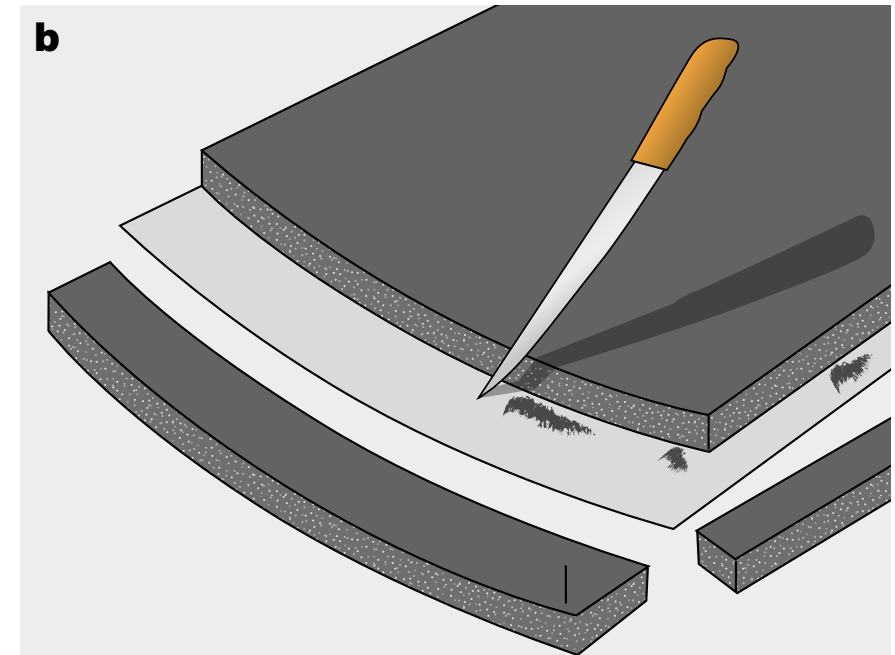

MATERIALS



KEY



K 420 adhesive



Marine sealant

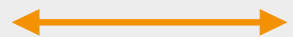

Measurements



Actions

K-FLEX® IN CLAD - LARGE TANKS

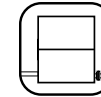

INSULATION AND COVERING WITH K-FLEX® ELASTOMERIC SHEET COVERED WITH IN CLAD SHEET

Covering of the tank's wall

Before applying the K-FLEX® IN CLAD sheets it is advisable to carefully clean the surface of traces of dirt, grease and oil to allow for proper adhesion.

Place the sheet sections in a circular fashion **(a)** starting from the bottom and working towards the top **(b)**.

Vary the arrangement of the vertical joints for greater absorption of the expansion of the insulation.

At the top of the wall, a special operation is needed for the connection with the roof of the tank, which we will come to further on, when we have defined the application method for the sections placed onto the wall.

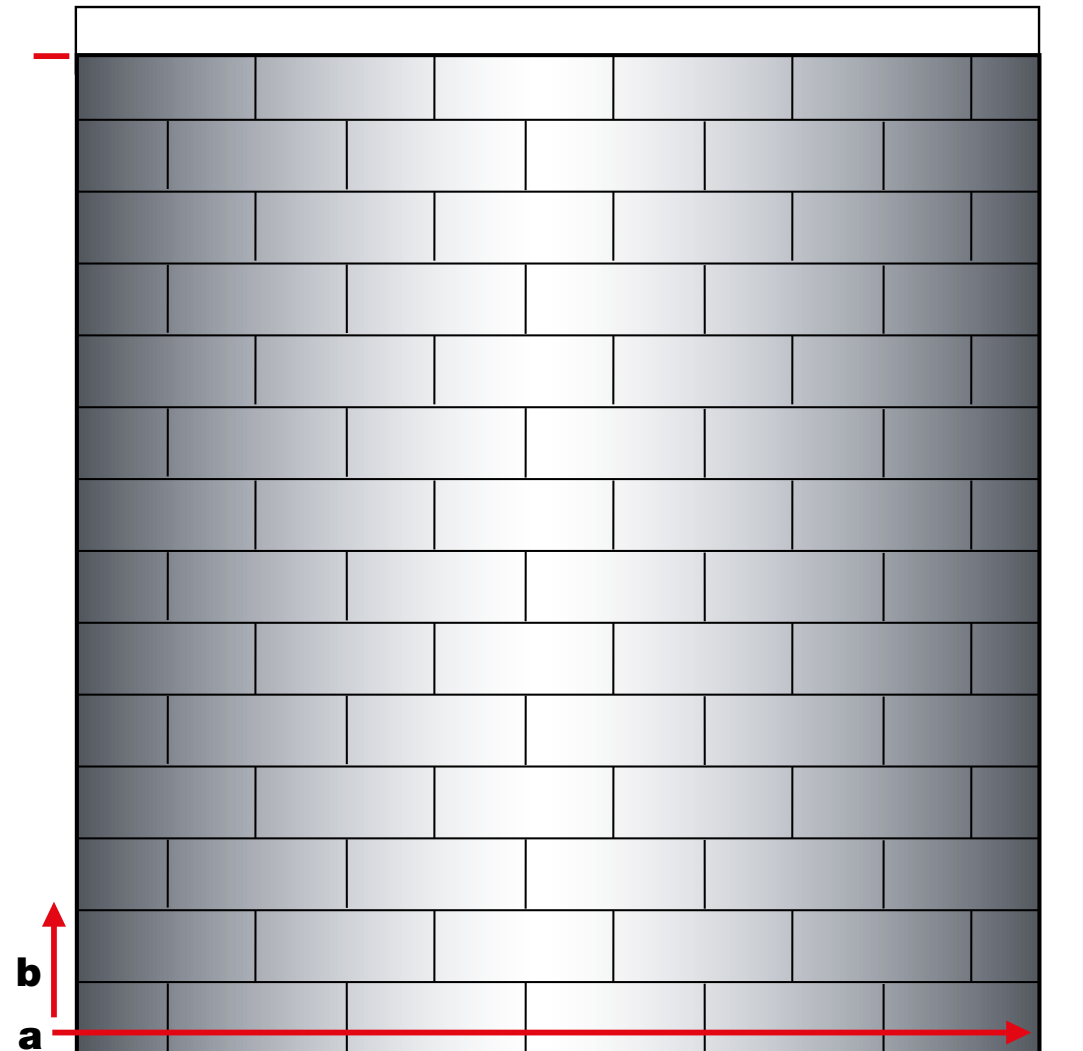

MATERIALS

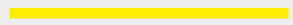
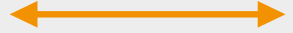
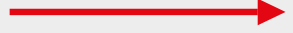

KEY

-  K 420 adhesive
-  Marine sealant
-  Measurements
-  Actions

K-FLEX® IN CLAD - LARGE TANKS

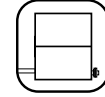

INSULATION AND COVERING WITH K-FLEX® ELASTOMERIC SHEET COVERED WITH IN CLAD SHEET

Covering of the tank's

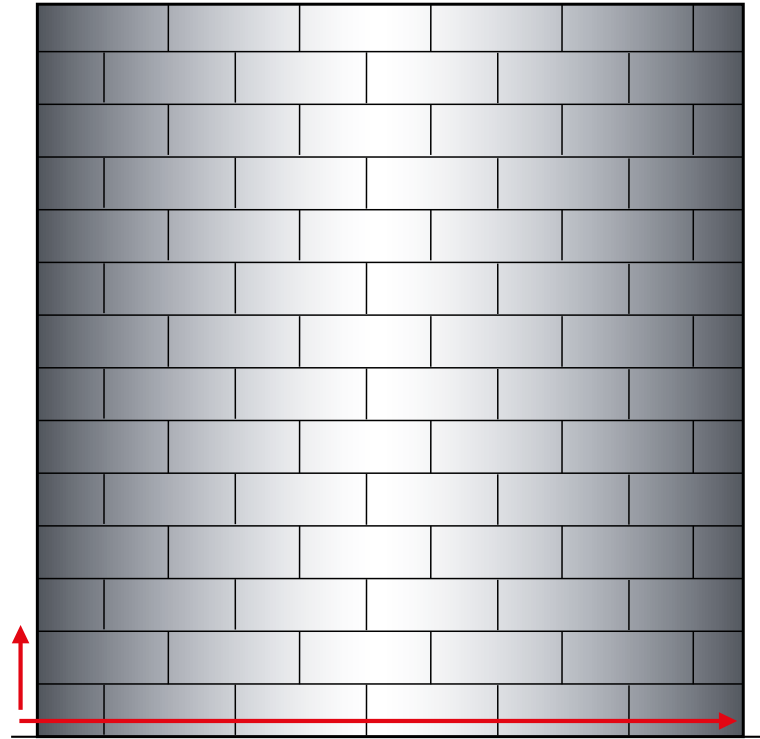

Fix the joints with adhesive.

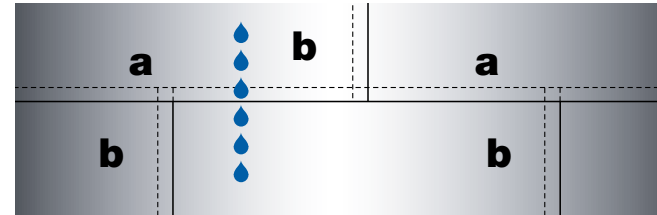
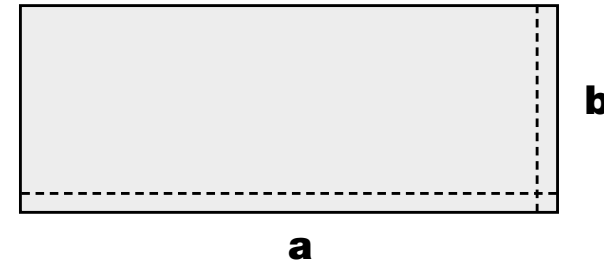
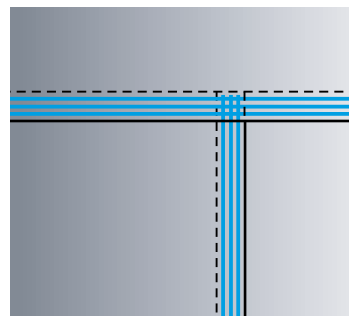



The overlapping of the abundances should always be placed above the underlying sections to allow water to flow above the joints (◆).

The overlapping abundances between horizontal adjacent sheets should always be placed on the same part, for practical and aesthetic reasons **b**).

MATERIALS

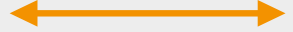
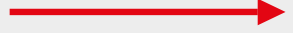

KEY

-  K 420 adhesive
-  Marine sealant
-  Measurements
-  Actions

K-FLEX® IN CLAD - LARGE TANKS

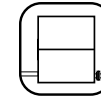

INSULATION AND COVERING WITH K-FLEX® ELASTOMERIC SHEET COVERED WITH IN CLAD SHEET

Covering the top of the tank's wall

On the top of the wall apply sections of IN CLAD sheet correctly joined on overlapping edges (**a**), on which will be made an indentation (**b**) which will be folded 90° above the surface of the roof and fixed with glue (**c**).

The lower part should have an abundance for the overlapping of the underlying sections (**d**).

Calculate how many sections of sheet are needed to cover the top of the tank.

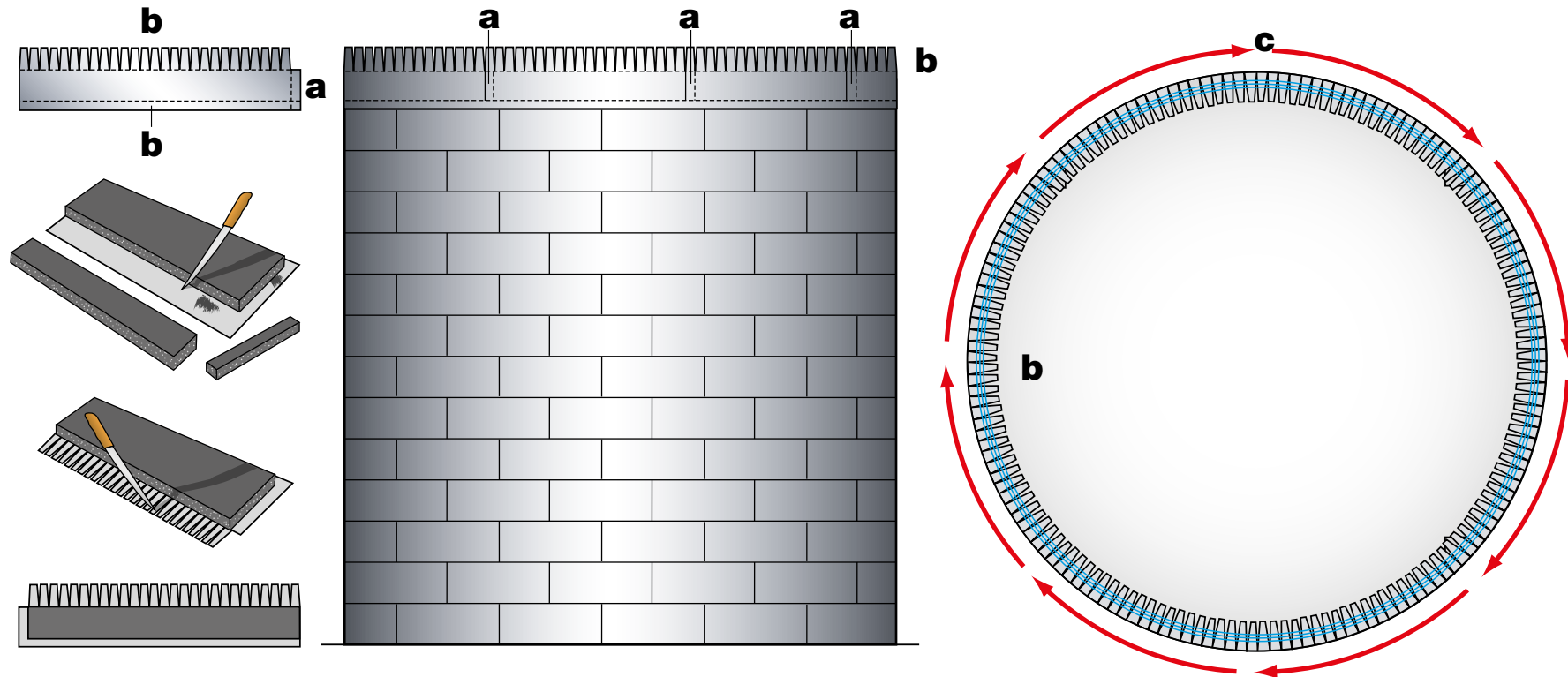

MATERIALS



KEY



K 420 adhesive



Marine sealant



Measurements



Actions

K-FLEX® IN CLAD - LARGE TANKS

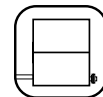

INSULATION AND COVERING WITH K-FLEX® ELASTOMERIC SHEET COVERED WITH IN CLAD SHEET

Insulation of the tank's roof

For the finishing to apply on the roof of the tank, use sheets of 1 m in height (corresponding to that of the K-FLEX® IN CLAD sheets) placed to cover the whole surface.

With careful planning (it is advisable to prepare a diagram to calculate the correct dimensions of the project) the elastomeric sheets can be placed in a functional manner, to allow for gradual overlaying folded towards the external parts and to help the flow of water towards the walls of the tank.

Place the K-FLEX® IN CLAD sheets starting from the external layer (**a**) towards the center. The rounded edges of the external sections should follow the curvature of the tank.

Place the sheets after having cleaned the surface of the tank of traces of dirt, oil and grease, so as not to jeopardize adhesion.

The surface where the sheets come into contact with the tank should be glued with adhesive (**b**).
Glue together the overlapping edges of the adjacent sheets (**c**).
In the joining edges of the sections, avoid tension and distortions, to allow for correct adhesion and to add to its aesthetic value.

To avoid detachments and infiltrations the insulation of the walls of the tank must be carefully sealed to the perimetrical joint.
The insulation of the roof must overlap the perimetrical insulation (**d**).

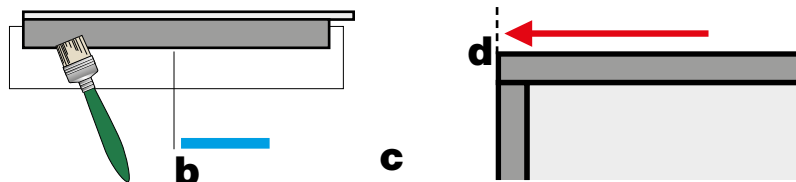
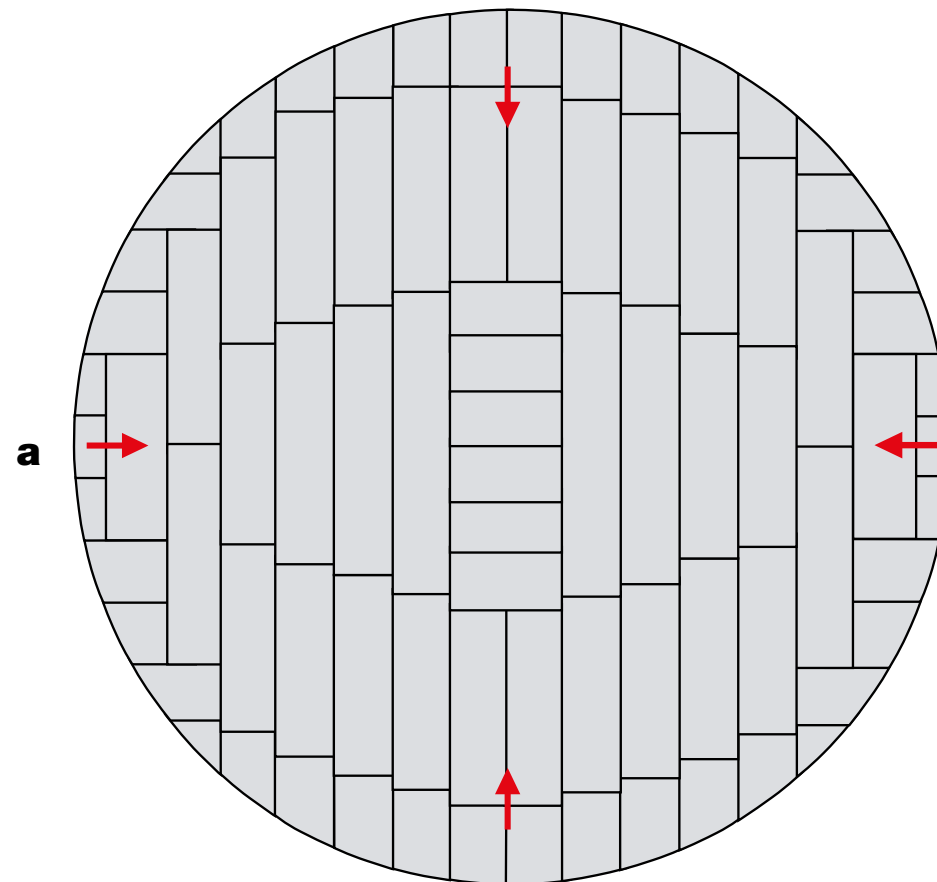

For the preparation of the covering K-FLEX® IN CLAD sections see the following pages.

MATERIALS



KEY



K 420 adhesive



Marine sealant

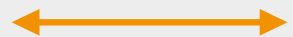

Measurements



Actions

K-FLEX® IN CLAD - LARGE TANKS

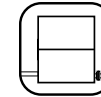

INSULATION AND COVERING WITH K-FLEX® ELASTOMERIC SHEET COVERED WITH IN CLAD SHEET

Finishing K-FLEX® IN CLAD covering sections

It is necessary to also protect the thickness of the curved side, turned towards the outside. In order to allow water to flow out the external edge, it is necessary to allow on the curved side another abundance (a) which includes the dimension of the K-FLEX® sheet's thickness plus 5/10 cm needed for an adequate overlapping to the sheet of the underlying wall (b). If necessary, make a cut in the overlap (c) to absorb the tension of the curvature. Glue the overlap with adhesive.

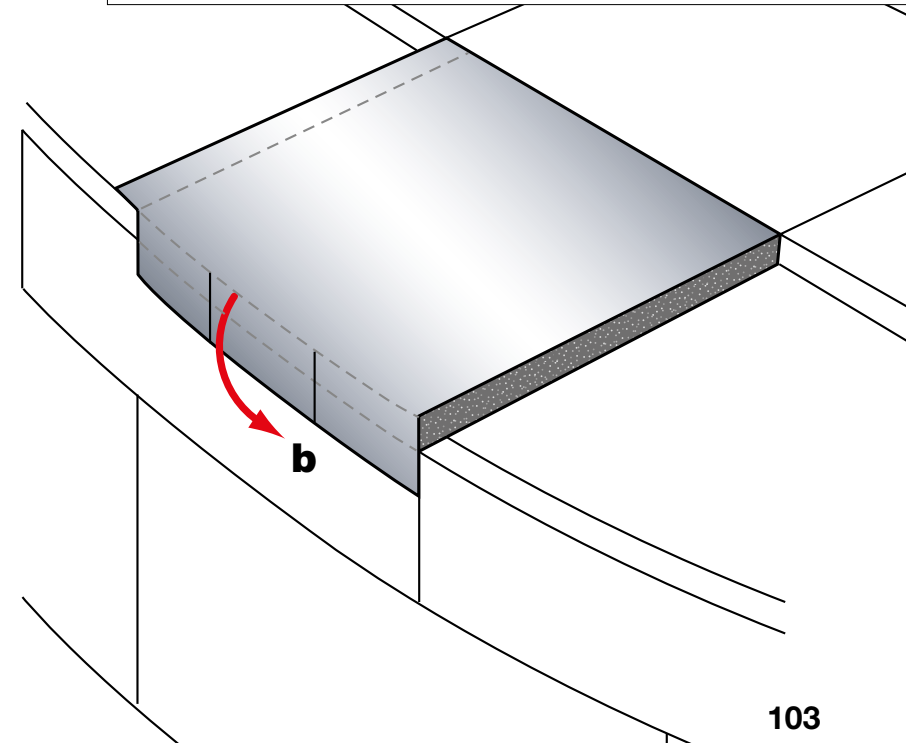
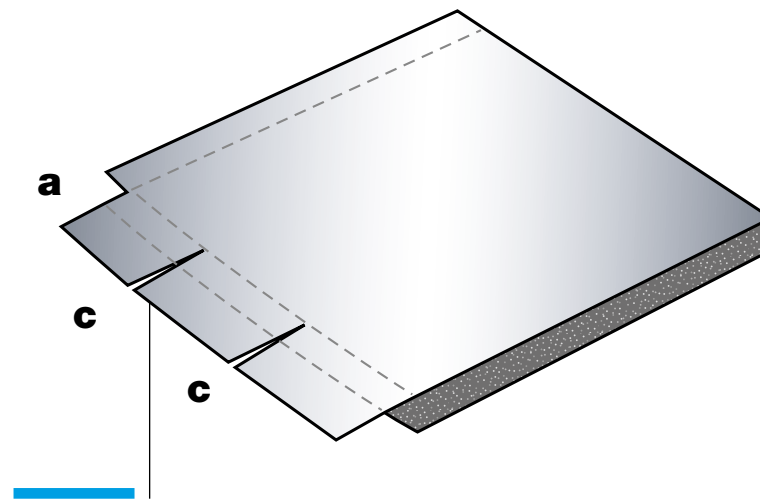
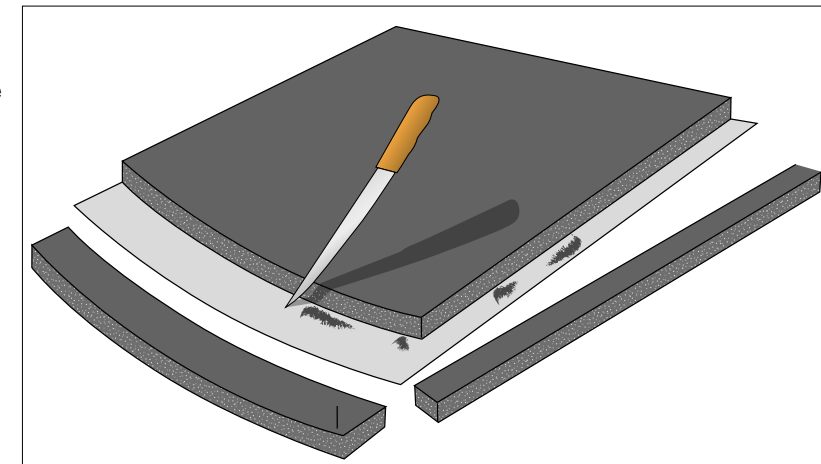

MATERIALS



KEY



K 420 adhesive



Marine sealant



Measurements



Actions

K-FLEX® IN CLAD - LARGE TANKS

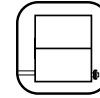

INSULATION AND COVERING WITH K-FLEX® ELASTOMERIC SHEET COVERED WITH IN CLAD SHEET

Preparation of the internal covering K-FLEX® IN CLAD sections

Take the measurements and cut out the elastomeric sheet leaving the correct abundance for the overlay (a).
Remove the elastomeric part from the areas of the abundance.

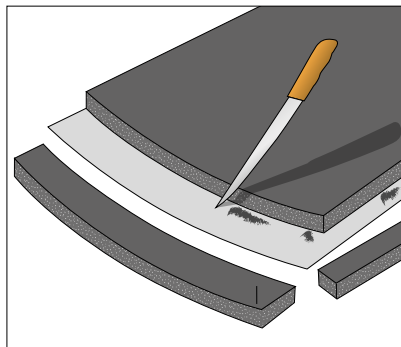

First place the external sheet sections* and then proceed gradually towards the center of the roof, overlaying every sheet to those layed before.

In that way the slightest difference in level of the overlappings will allow water to flow towards the outside (💧).

Glue the joints of the IN CLAD sheet with adhesive.

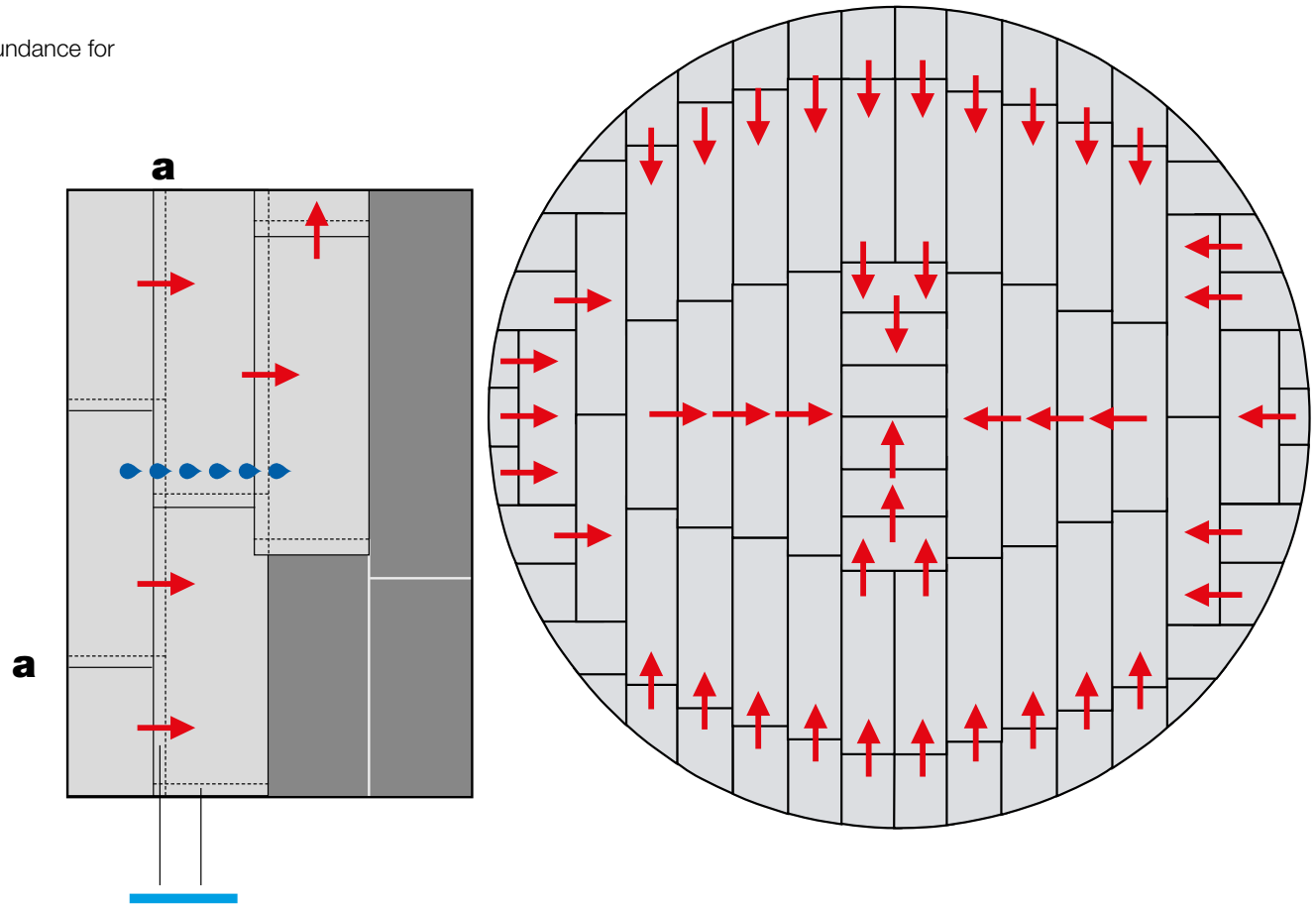

MATERIALS



KEY



K 420 adhesive



Marine sealant



Measurements



Actions

K-FLEX® IN CLAD - LARGE TANKS

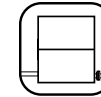

INSULATION AND COVERING WITH K-FLEX® ELASTOMERIC SHEET COVERED WITH IN CLAD SHEET

Accurately seal all the joints and the edges of the tapes with marine sealant. If necessary, seal the joints with the specific IN CLAD tape secured with glue. The longevity of the finishing depends very much on the care and attention with which this operation is initially carried out.

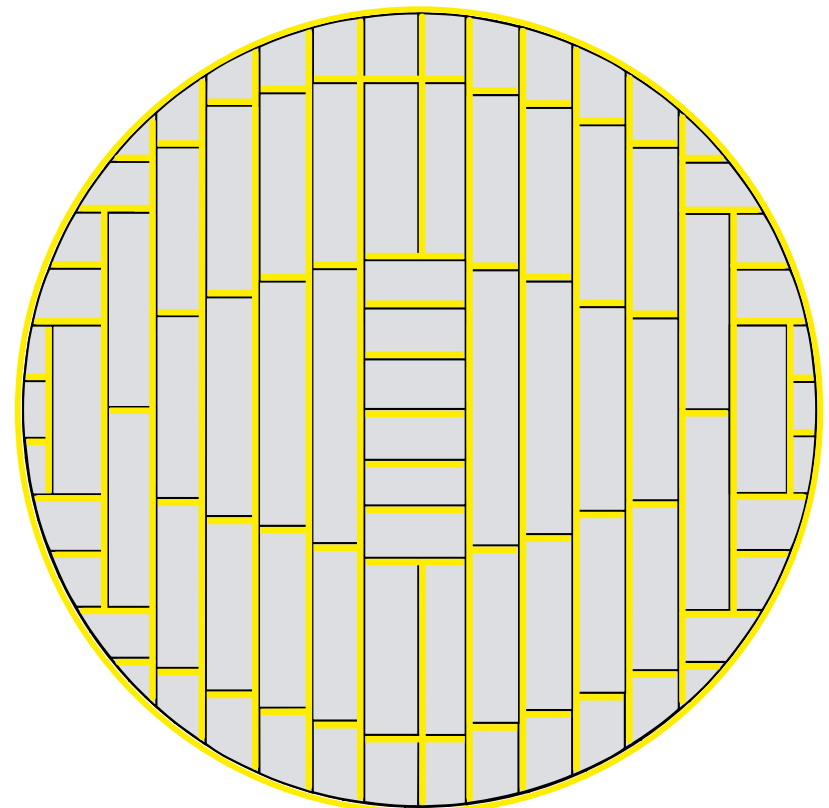
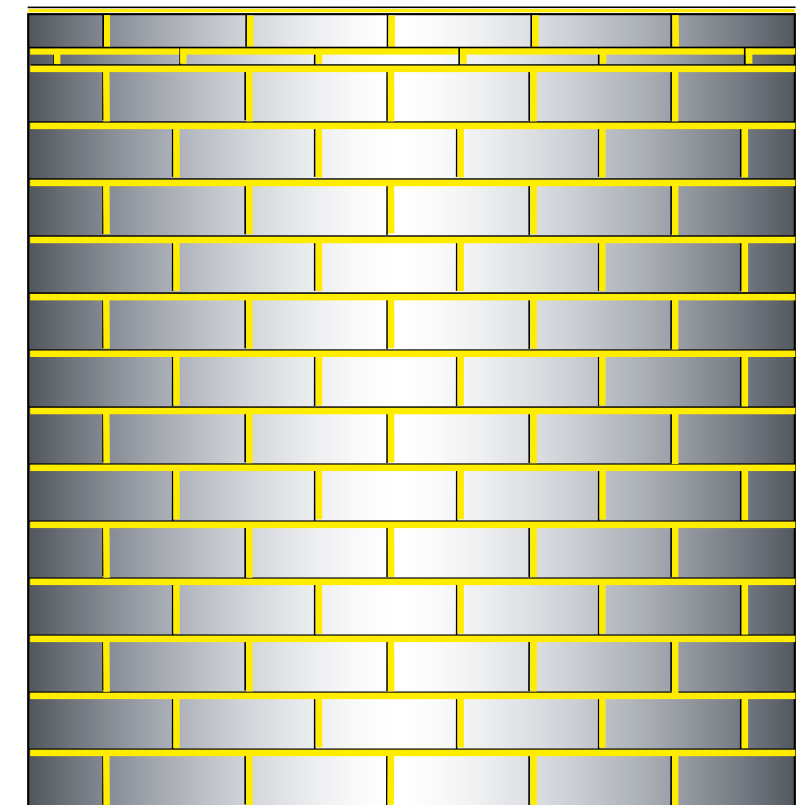

DISCLAIMER

- ▶ **1.** This product must be stored in a protected location, where temperature conditions do not exceed the recommended limits for use of the product and its packaging.
- ▶ **2.** Storage (loading/picking/handling) conditions must be adequate so as to avoid any mechanical stress which may cause damage and deterioration in the characteristics of the product.
- ▶ **3.** Please ensure that the product never comes into contact with any aggressive substances, either during storage or when being handled, such as - in particular, but by no means exclusively - benzoic acid, carbon tetrachloride, Decalin.
- ▶ **4.** In the event of spillage and eventual disposal of the product, please refer to the relevant Material Safety Data Sheet.
- ▶ **5.** Product installation should be carried out in line with the manufacture's installation manual. (K-FLEX® IN CLAD INSTRUCTION MANUAL)
- ▶ **6.** Attention should be paid to the technical specification of the product in relation to the environment which has to be installed and operated in.
- ▶ **7.** The product should always be installed using the accessories and finishing products specially developed and approved by K-FLEX®. Under no circumstances should be used products which have not been specified by K-FLEX® (e.g., glues, adhesives, sealants, silicones, solvents, abrasives, mastics, etc.).
- ▶ **8.** During pattern making, cutting and installation of the product, it is important that the material is not subject to temperature variations in excess of 5°C, as possible distortion of the product may occur.
- ▶ **9.** K-FLEX® recommends that the preparation of the product is carried out in the vicinity of the final installation.
- ▶ **10.** During installation, the product must not be mechanically stressed with loads likely to produce a state of stress above the limits given in the product specification.
- ▶ **11.** At ambient temperatures above 30°C the product will become more flexible. Therefore it is advised that the product should not be left in direct sunlight and / or high ambient temperatures before installation.
- ▶ **12.** Installation of the product can be carried out in a wide range of temperatures; due to potentially large differentials in temperature from manufacture, some shrinkage might become evident in the direction of lamination. This is quite normal, but should be taken into consideration during the installation.



CONTACT

L'ISOLANTE K-FLEX S.p.A.

Via Don Locatelli, 35 - 20877 Roncello (MB) - Italy

Sales Dept.

E-mail: internationalsales@kflex.com

Tel.: +39 039 6824.1

Technical Marketing Dept.

E-mail: kflex-technical@kflex.com

www.kflex.com

2019